

# Standard Ball screws

- Fixing dimensions according to DIN 69051 (1989)
- Preloaded or without clearance
- Precision grade Cp/Ct according to ISO 3408-3



# THK Precision Ballscrews

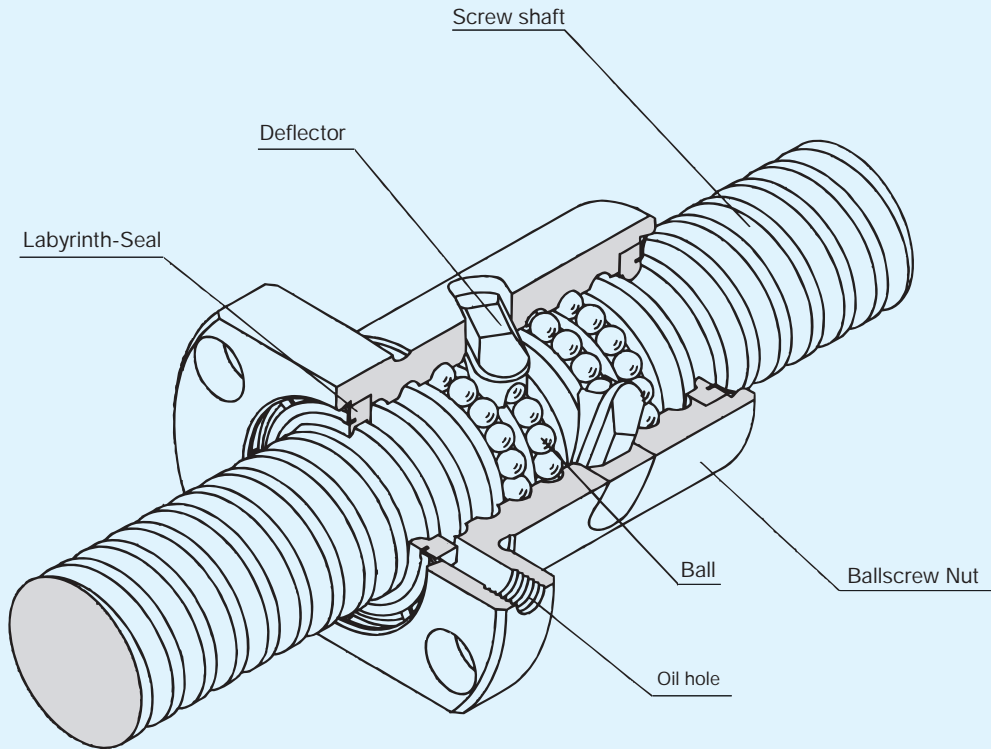

Fig. 1 Construction of a simple nut ballscrew

## • Availability

THK precision ballscrews can be delivered with the following specifications at short notice:

- according to DIN 69051, part 5 (ISO 3408-5)
- with THK standard dimensions
- with large lead

## • Precision Rolled Ballscrews

Ground precision ballscrews are best suited for applications, where high axial rigidity is required. Precision rolled ballscrews are a cost-effective alternative to ground ground ballscrews. These products match the accuracy grades of the standard DIN 69051, part 3, as well as ISO 3408-3.

Standard		JIS (Jap. industrial standard)		DIN/ISO		
Accuracy grade		C3	C5	Cp3	Cp5	Ct5
Manufacturing method		Ground		Precision rolled		
Preload	Double nut	0.05 Ca	0.05 Ca	0.05 Ca	0.05 Ca	—
	Pitch shifted	0.05 Ca	0.05 Ca	0.02 Ca	0.02 Ca	—
	Ball selection	0.02 Ca	0.02 Ca	Without clearance	Without clearance	Without clearance

## • Support Units and Screw Shafts with Finished Ends Available

THK precision ballscrews can be delivered with support units and the appropriate shaft ends.

## Product Overview

### Precision Ballscrews According to DIN 69051 (1989)

#### EPA/EBA (Form A)

Single nut  
preloaded/without clearance



Page 20/26

Available screw shaft diameter × lead:  
16×05 ~ 63×20

#### EPB/EBB (Form B)

Single nut  
preloaded/without clearance



Page 22/28

Available screw shaft diameter × lead:  
16×05 ~ 63×20

#### EPC/EBC (Form C)

Single nut  
preloaded/without clearance



Page 24/30

Available screw shaft diameter × lead:  
16×05 ~ 63×20

### THK Ballscrews with Standard Dimensions

#### BIF

Single nut preloaded



Page 32

Available screw shaft diameter × lead:  
16×05 ~ 63×20

#### BNFN

Double nut preloaded



Page 34

Available screw shaft diameter × lead:  
16×05 ~ 63×20

#### BNF

Single nut



Page 36

Available screw shaft diameter × lead:  
16×05 ~ 63×20

### Large Lead

#### BLK

Single nut without clearance



Page 38

Available screw shaft diameter × lead:  
16×16 ~ 40×40

### Support Units

#### BK/BF - EK/EF



Page 40

# Screw Shaft Selection

## Available Diameter/Lead Combinations

The tables below indicate the standard combinations of the screw shafts and leads. If a diameter and lead combination other than those specified in the tables is required, please contact **THK**.

- Standard
- △ Semi-Standard

Table 1 EB/EP Series (ground) Unit: mm

Precision class		C3 and C5		
		Lead		
		5	10	20
Screw shaft diameter	16	●	—	—
	20	●	—	—
	25	●	●	—
	32	●	●	—
	40	●	●	●*
	50	●	●	●*
	63	—	●	●

\* only EB

Table 2 EB/EP Series (precision rolled) Unit: mm

Precision class		Cp3 and Cp5		
		Lead		
		5	10	20
Screw shaft diameter	16	●	—	—
	20	●	—	—
	25	●	●	—
	32	●	●	—
	40	—	●	●*
	50	—	—	—
	63	—	—	—

\* only EB

Table 3 BIF/BNFN/BNF Series (ground) Unit: mm

Precision class		C3 and C5		
		Lead		
		5	10	20
Screw shaft diameter	16	●	—	—
	20	●	—	—
	25	●	●	—
	32	●	●	—
	40	△	●	△
	50	△*	●	—
	63	—	△	△

\* only BNFN and BNF

Table 4 BIF/BNFN/BNF Series (precision rolled) Unit: mm

Precision class		Cp3 and Cp5		
		Lead		
		5	10	20
Screw shaft diameter	16	△	—	—
	20	△	—	—
	25	△	△	—
	32	△	△	—
	40	—	△	△
	50	—	—	—
	63	—	—	—

Table 5 BLK Series (precision rolled) Unit: mm

Precision class		Ct5				
		Lead				
		16	20	25	32	40
Screw shaft diameter	16	●	—	—	—	—
	20	—	●	—	—	—
	25	—	—	●	—	—
	32	—	—	—	●	—
	40	—	—	—	—	●

## Limitations of Screw Shafts Lengths

Table 6 presents the maximum screw shaft lengths by accuracy grade for rolled and precision ballscrews. If the requested shaft length exceeds the range specified in the table below, please contact **THK**.

Table 6 Limitations of screw shaft length by accuracy grade

Unit: mm

Screw shaft diameter	Ground		Precision rolled		
	C3	C5	Cp3	Cp5	Ct5
16	550	550	1100	1250	1400
20	850	850	1600	1700	1800
25	1260	1260	2000	2200	2400
32	1670	1670	2800	3000	3200
40	2070	2070	3700	4000	4300
50	2600	2600	—	—	—
63	2600	2600	—	—	—

## Permissible Rotational Speed

### Dangerous screw shaft speed

At high rotational speeds, the ballscrew causes resonance due to the characteristic frequency of the screw shaft, which may make operation impossible. The shaft speed should therefore be set at a level below the resonant point (critical speed).

Figure 1 indicates the relationship between screw-shaft diameter and critical speed.

Permissible rotational speed based on the critical speed can be calculated using equation (8), wherein 0.8 is used as a safety factor.

$$N_1 = \frac{60 \cdot \lambda_1^2}{2\pi \cdot \ell_b^2} \times \sqrt{\frac{E \cdot 10^3 \cdot I}{\gamma \cdot A}} \times 0.8 = \lambda_2 \cdot \frac{d_1}{\ell_b^2} \cdot 10^7$$

where

$N_1$ : permissible rotational speed determined based on the critical speed (min<sup>-1</sup>)

$\ell_b$ : distance between mounting positions (mm)

$E$ : Young's modulus (2.06 × 10<sup>5</sup> N/mm<sup>2</sup>)

$I$ : minimum geometrical moment of inertia of the screw-shaft cross section (mm<sup>4</sup>)

$$I = \frac{\pi}{64} \cdot d_1^4 \quad d_1: \text{Screw-shaft thread min diameter (mm)}$$

$\gamma$ : density (specific gravity) (7.85 × 10<sup>-6</sup> kg/mm<sup>3</sup>)

$A$ : screw-shaft cross-sectional area (mm<sup>2</sup>)

$$A = \frac{\pi}{4} \cdot d_1^2$$

$\lambda_1$  and  $\lambda_2$  = coefficient depending on the mounting method

Fixed/free:  $\lambda_1 = 1.875$   $\lambda_2 = 3.4$

Supported/supported:  $\lambda_1 = 3.142$   $\lambda_2 = 9.7$

Fixed/supported:  $\lambda_1 = 3.927$   $\lambda_2 = 15.1$

Fixed/fixed:  $\lambda_1 = 4.730$   $\lambda_2 = 21.9$

## DN Value

### DN value

The permissible rotational speed of the ballscrew should be determined based on the critical speed and DN value.

The permissible rotational speed determined based on the DN value can be calculated using equations (1) through (3).

- Precision-Ground Ballscrew

$$N_2 = \frac{100\,000}{D} \dots\dots\dots (1)$$

(For BNF, BNFN, BIF and BLK 70.000)

where

$N_2$ : permissible rotational speed determined based on the DN value (min<sup>-1</sup>)

$D$ : ball center-to-center diameter (presented in the dimension table) (mm)

- Rolled Ballscrew (excluding the large-lead type)

$$N_2 = \frac{50\,000}{D} \dots\dots\dots (2)$$

- Large-Lead Rolled Ballscrew

$$N_2 = \frac{70\,000}{D} \dots\dots\dots (3)$$

$N_1$  or  $N_2$ , whichever is lower, is taken as the permissible rotational speed.

For operating rotational speeds greater than  $N_2$ , high-speed ballscrew models are available. If you require these models, please contact us.

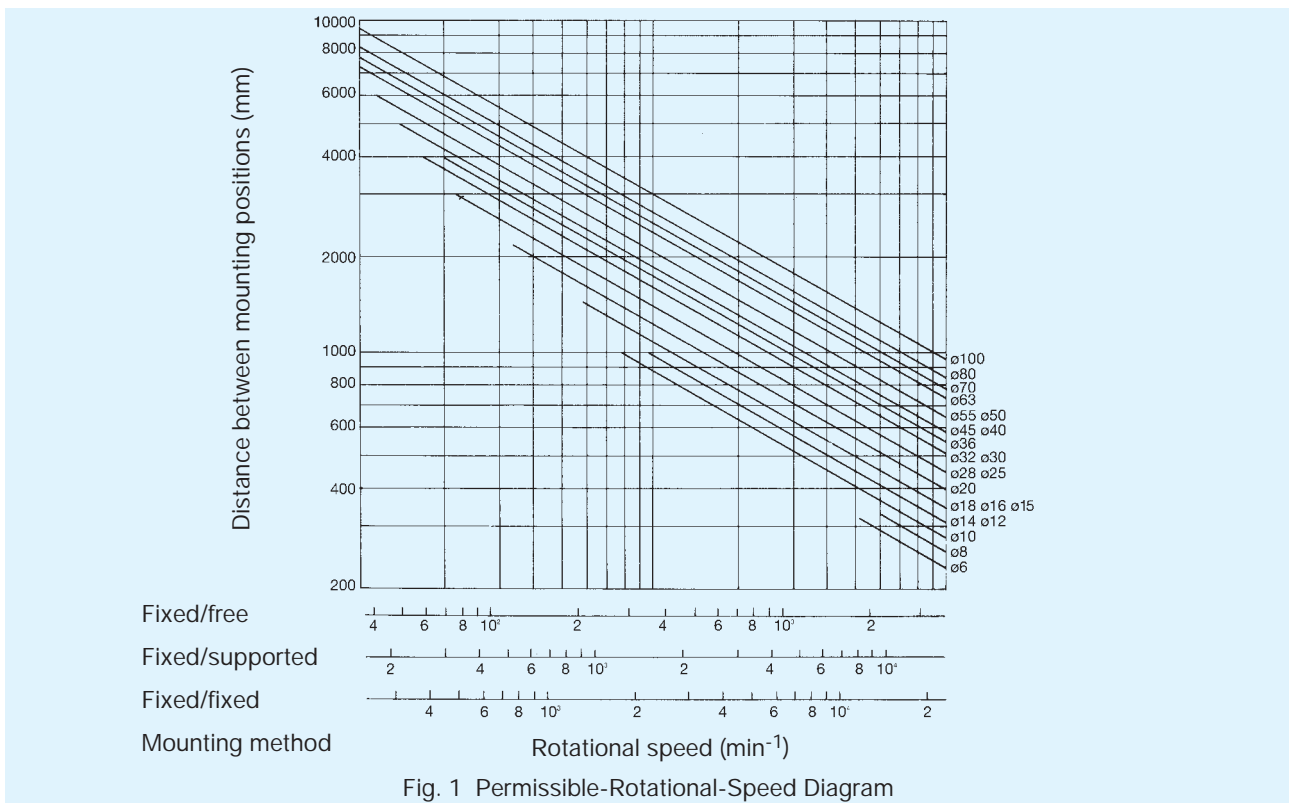

Fig. 1 Permissible-Rotational-Speed Diagram

## Permissible Axial Load

### Screw-shaft buckling load

The ballscrew to be used should not buckle under the maximum compressive load applied in its axial direction.

Figure 2 shows the relationship between the screw-shaft diameter and the buckling load.

The buckling load can be calculated using equation (4), wherein 0.5 is used as a safety factor.

$$P_1 = \frac{n_1 \cdot \pi^2 \cdot E \cdot I}{\ell_a^2} \cdot 0.5 = n_2 \cdot \frac{d_1^4}{\ell_a^2} \cdot 10^4 \dots \dots \dots (4)$$

where

- $P_1$ : buckling load (N)
- $\ell_a$ : distance between mounting positions (mm)
- $E$ : Young's modulus ( $2.06 \times 10^5$  N/mm<sup>2</sup>)
- $I$ : minimum geometrical moment of inertia of the screw-shaft cross section (mm<sup>4</sup>)

$$I = \frac{\pi}{64} \cdot d_1^4$$

$d_1$ : Screw-shaft thread min diameter (mm)

$n_1$  and  $n_2$ : coefficient depending on the mounting method

Fixed/free:	$n_1 = 0.25$	$n_2 = 1.3$
Fixed/supported:	$n_1 = 2.0$	$n_2 = 10.0$
Fixed/fixed:	$n_1 = 4.0$	$n_2 = 20.0$

### Permissible tensile-compressive load of the screw shaft

Where an axial load is exerted on the ballscrew, the screw shaft to be used should be determined in consideration of buckling load and the permissible tensile-compressive load that can exert yielding stress on the shaft.

The permissible tensile-compressive load can be calculated using equation (5).

$$P_2 = \delta \cdot \frac{\pi}{4} \cdot d_1^2 = 116 \cdot d_1^2 \dots \dots \dots (5)$$

- $P_2$ : permissible tensile-compressive load (N)
- $\delta$ : permissible tensile-compressive stress (147 N/mm<sup>2</sup>)
- $d_1$ : screw-shaft thread minor diameter (mm)

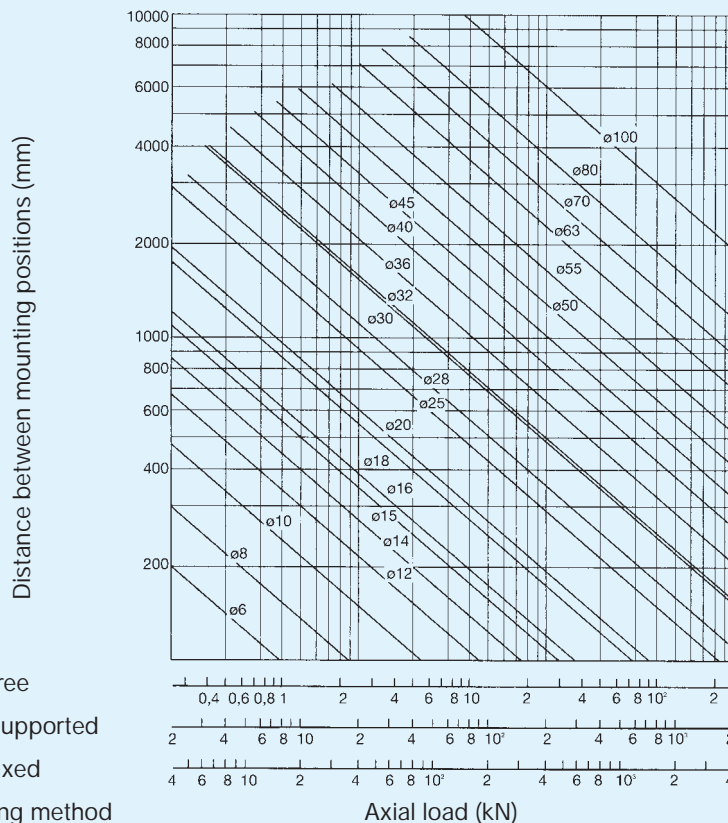

Fig. 2 Permissible-Axial-Load Diagram

## Static Safety Factor

If the ballscrew, whether at rest or in motion, receives an excessive load or significant impact, localized permanent deformation develops between the raceway and balls.

Over a certain level, the permanent deformation hinders the smooth movement of the ballscrew. Normally, the basic static load rating ( $C_{0a}$ ) is taken as the permissible axial load.

### Basic static load rating ( $C_{0a}$ )

The basic static load rating is the static load with a non-varying direction and magnitude that makes the sum of the permanent deformation of the rolling elements and raceway 0.0001 times the rolling-element diameter. With the ballscrew, the basic static load rating is defined in relation to the axial load.

Various values for the ballscrew are presented in the corresponding dimension tables in this catalog.

### Static safety factor

The basic static load rating ( $C_{0a}$ ) is normally equal to the permissible axial load of the ballscrew. Depending on the operating conditions, use of a static safety factor such as that specified below should be considered. Please be aware that the ballscrew may receive an unpredictable external force due to vibration and impact while it is at rest or in motion, or due to inertia resulting from starting and stopping.

$$F_{a\max} = \frac{C_{0a}}{f_s}$$

$F_{a\max}$  : Permissible axial load (kN)  
 $C_{0a}$  : Basic static load rating (kN)  
 $f_s$  : Static safety factor (see Table 7)

Table 7 Static Safety Factor ( $f_s$ )

Host machine	Load conditions	$f_s$ lower limit
General industrial machine	When not subjected to vibration or impact	1.0 ~ 1.3
	When subjected to vibration and impact	2.0 ~ 3.0
Machine tool	When not subjected to vibration or impact	1.0 ~ 1.5
	When subjected to vibration and impact	2.5 ~ 7.0

## Considering Service Life

### Service life of ballscrew units

The ballscrew in motion under an external load receives repeated stress on its raceways and balls. When the stress reaches a certain point, the raceways fatigue and eventually break, and their surfaces peel. Such peeling is called flaking.

The service life of a ballscrew unit is the total number of revolutions that the unit achieves before the first flaking occurs as a result of the rolling fatigue of the raceways or balls.

The service life of ballscrew units varies greatly from unit to unit, even if they are manufactured to the same specifications and remain in service under the same operating conditions. Therefore, guidelines for determining the service life of a ballscrew unit are given based on the nominal life, which is defined below.

The nominal life is the total number of revolutions that 90% of identical ballscrew units in a group, when operated independently of one another under the same conditions, can achieve without developing flaking.

### Basic dynamic load rating $C_a$

The basic dynamic load rating ( $C_a$ ) of the ballscrew is used to calculate its service life when it is operated under a load.

The basic dynamic load rating ( $C_a$ ) is the load with a nonvarying direction and magnitude that makes the nominal life  $L$  of identical ballscrew units in a group, when operated independently of one another,  $10^6$  (revolutions). (Basic dynamic load rating  $C_a$  is presented in the corresponding dimension tables.)

The dynamic load  $C_a$  is based on the calculation method according to ISO 3408-5 respectively DIN 69051 (1989). This calculation method is defined by the European and Japanese ballscrew manufacturers as a universally valid standard.

### Service-life calculation

The nominal life of the ballscrew can be calculated by an equation (6) using the values for the basic dynamic load rating ( $C_a$ ) and applied axial load.

#### (1) Nominal life (total number of revolutions)

$$L = \left( \frac{C_a}{f_w \cdot F_a} \right)^3 \cdot 10^6 \dots \dots \dots (6)$$

where

$L$  : nominal life (total number of revolutions) (rev)  
 $C_a$  : basic dynamic load rating (N)  
 $F_a$  : applied axial load (N)  
 $f_w$  : load factor (see table 8)



Table 8 Load Factor ( $f_w$ )

Vibration and impact	Velocity (V)	$f_w$
Very light	Very low: $V \leq 0.25$ m/s	1.0 ~ 1.2
Light	Low: $0.25 < V \leq 1.0$ m/s	1.2 ~ 1.5
Medium	Intermediate: $1.0 < V \leq 2.0$ m/s	1.5 ~ 2.0
Heavy	High: $V > 2.0$ m/s	2.0 ~ 3.5

**(2) Service life in hours**

If the number of revolutions per minute is known, the service life in hours can be calculated by an equation (7) using the value for the nominal life (L).

$$L_h = \frac{L}{60 \cdot n} = \frac{L \cdot \ell}{2 \cdot 60 \cdot S \cdot \ell_s} \dots\dots\dots (7)$$

where

- $L_h$  : service life in hours (h)
- $n$  : number of revolutions per minute ( $\text{min}^{-1}$ )
- $S$  : number of reciprocal operations per minute ( $\text{min}^{-1}$ )
- $\ell$  : ballscrew lead (mm)
- $\ell_s$  : stroke length (mm)

**(3) Service life in running distance**

This can be calculated by an equation (8) using the values for the nominal life (L) and the ballscrew lead.

$$L_s = \frac{L \cdot \ell}{10^6} \dots\dots\dots (8)$$

where

- $L_s$  : service life in running distance (km)
- $\ell$  : ballscrew lead (mm)

**(4) Applied load and service life in consideration of the preload**

For a ballscrew used with a preload (medium) applied to the nut, the service life should be calculated in consideration of the preload, which is the internal load on the nut. If you have questions about the preload, please contact us, and be sure to specify the relevant model number.

**(5) Mean axial load**

When the axial loads applied to the ballscrew fluctuate, the service life should be calculated based on the mean axial load of the varying axial loads.

The mean axial load ( $F_m$ ) is the load that makes the service life of the ballscrew equivalent to that under varying loads exerted during operation.

Where loads vary incrementally, the mean axial load can be obtained using the following equation:

$$F_m = \sqrt[3]{\frac{1}{L} (F_{a1}^3 \ell_1 + F_{a2}^3 \ell_2 + \dots + F_{an}^3 \ell_n)} \dots\dots (9)$$

- $F_m$  : mean axial load (N)
- $F_{an}$  : varying load (N)
- $\ell_n$  : running distance achieved under load ( $F_n$ ) (mm)
- $L$  : total running distance (mm)

To determine the service life in the number of revolutions or hours instead of distance, obtain the distance using the equation shown below, and calculate the mean axial load.

$$\begin{aligned} \ell &= \ell_1 + \ell_2 + \dots + \ell_n \\ \ell_1 &= N_1 \cdot t_1 \\ \ell_2 &= N_2 \cdot t_2 \\ \ell_n &= N_n \cdot t_n \end{aligned}$$

where

- $N$  : number of revolutions
- $t$  : time

# Ballscrew Accuracy Grades

## Travel Variation and Travel Deviation

The accuracy grades of the precision rolled ballscrews are related to standards ISO 3408 and DIN 69051. The accuracy grades of the ground ballscrews are controlled in accordance of the Japanese standard JIS B 1191 and JIS B 1192.

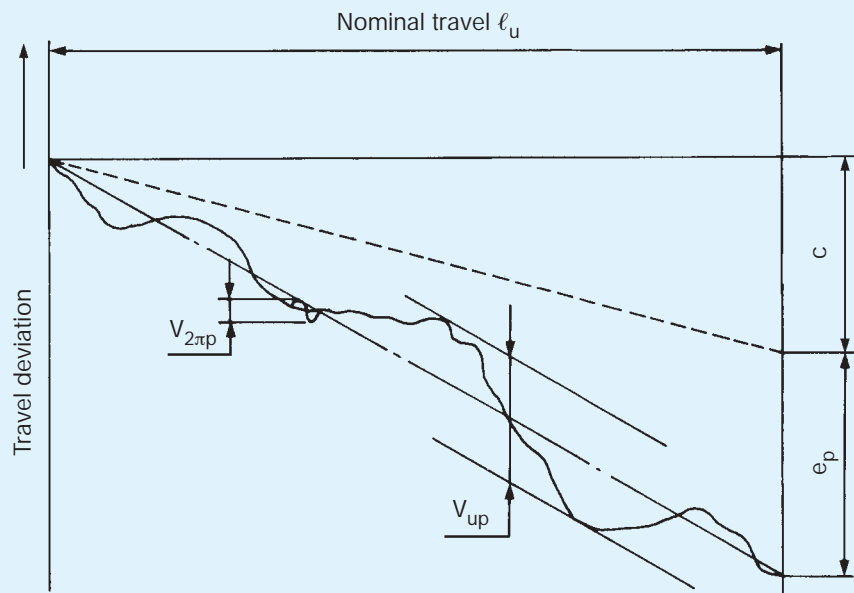

Figure 3 Permissible travel deviation and travel variation in relation to the nominal travel

### Definitions according to ISO 3408:

- $e_p$ : Tolerance on specified travel. The difference between the maximum and minimum values of the permissible actual mean travel.
- $V_{up}$ : Permissible travel variation in relation to the nominal travel  $\ell_u$ .
- $V_{2\pi p}$ : Permissible travel variation in relation to one rotation  $2\pi$  rad.
- $V_{300p}$ : Permissible travel deviation over 300 mm travel.
- $c$ : Travel compensation. The difference between the specified travel and nominal travel within the useful travel.

Table 1 Tolerance on specified travel  $\pm e_p$  and permissible travel variation  $V_{up}$  in relation to the nominal travel  $\ell_u$  for positioning ballscrews.

Unit:  $\mu\text{m}$

Standard		JIS				DIN/ISO			
THK Accuracy grade		C3		C5		Cp3 <sup>1)</sup>		Cp5 <sup>2)</sup>	
Nominal travel $\ell_u$ mm		ep	Vup	ep	Vup	ep	Vup	ep	Vup
Over	to (incl.)								
—	315	12	8	23	18	12	12	23	23
315	400	13	10	25	20	13	12	25	25
400	500	15	10	27	20	15	13	27	26
500	630	16	12	30	23	16	14	32	29
630	800	18	13	35	25	18	16	36	31
800	1000	21	15	40	27	21	17	40	34
1000	1250	24	16	46	30	24	19	47	39
1250	1600	29	18	54	35	29	22	55	44
1600	2000	35	21	65	40	35	25	65	51
2000	2500	41	24	77	46	41	29	78	59
2500	3150	50	29	93	54	50	34	96	69
3150	4000	62	35	115	65	62	41	115	82
4000	5000	76	41	140	77	76	49	140	99
5000	6300	—	—	170	93	—	—	170	119
6300	8000	—	—	213	115	—	—	—	—
8000	10000	—	—	265	140	—	—	—	—

Table 2 Permissible travel variation in relation to one rotation  $2_{\pi\text{rad}}$  and permissible travel variation over 300 mm travel for positioning ballscrews.

Unit:  $\mu\text{m}$

Standard	JIS		DIN/ISO	
THK Accuracy grade	C3	C5	Cp3 <sup>1)</sup>	Cp5 <sup>2)</sup>
$V_{300p}$	8	18	12	23
$V_{2\pi p}$	6	8	6	8

Table 3 Tolerance on specified travel  $e_p$  and permissible travel variation over 300 mm travel  $V_{300p}$  for transport ballscrews.

Unit:  $\mu\text{m}$

Standard	DIN/ISO
THK Accuracy grade	Ct5 <sup>3)</sup>
$e_p$	$e_p = 2 \frac{\ell_u}{300} V_{300p}$
$V_{up}$	not defined
$V_{300p}$	23
$V_{2\pi p}$	not defined

<sup>1)</sup> Cp3 = Positioning ballscrews of the accuracy grade 3 according to DIN 63051 part 3 / ISO 3408 part 3

<sup>2)</sup> Cp5 = Positioning ballscrews of the accuracy grade 5 according to DIN 63051 part 3 / ISO 3408 part 3

<sup>3)</sup> Ct5 = Transport ballscrews of the accuracy grade 5 according to DIN 63051 part 3 / ISO 3408 part 3

## Mounting Surface Accuracy C3 and C5

The mounting surface for the accuracy grades C3 and C5 of the ground precision ballscrews is specified in the Japanese standard JIS.

Only valid for the types BIF, BNFN, BNF, EB and EP

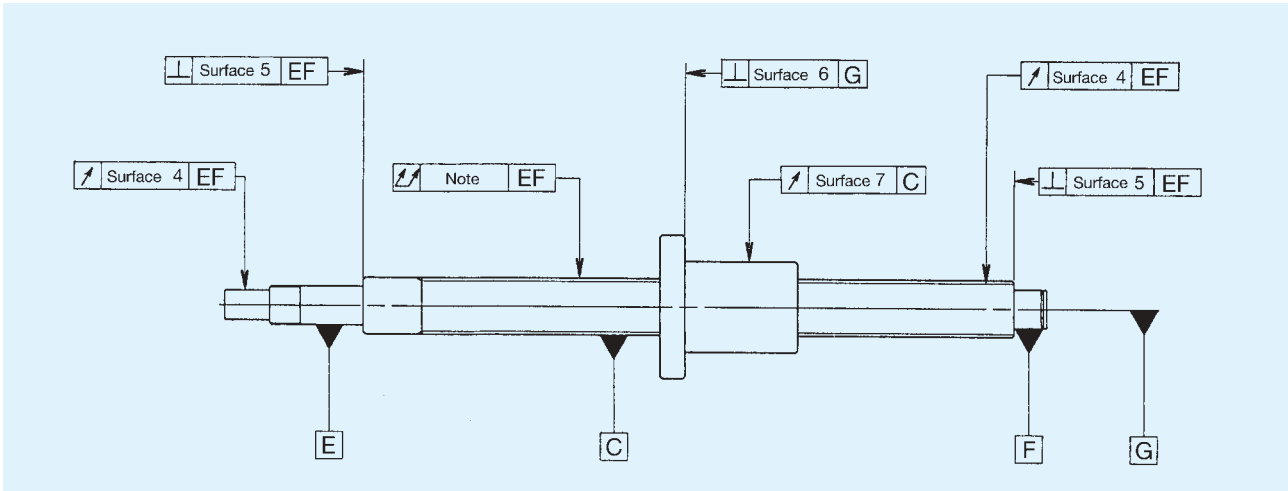

Notes: The overall radial runout of the screw shafts axis is defined in JIS B 1191 and 1192. For the radial run-out see table 8.

Table 4 Radial runout of the journal diameter in respect to EF

Shaft diameter $d_0$ (mm)		Journal diameter (max.)	
THK Accuracy grade		C3	C5
Over	Up to (incl.)		
12	20	9	12
20	32	10	13
32	50	12	15

Unit:  $\mu\text{m}$

Notes: For more detailed information see JIS B 1191 and JIS B 1192.

Example: Type BIF2005-RRG0 + 500LC5

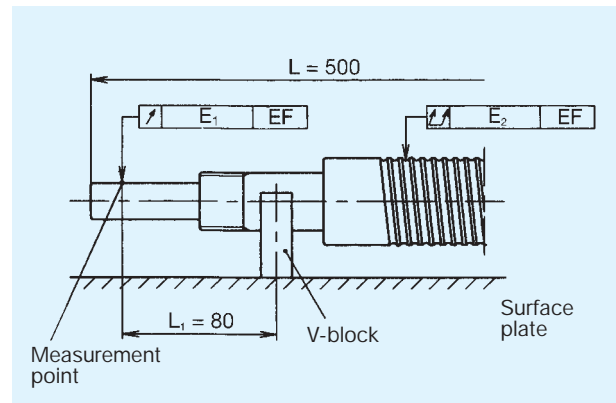

$$E_1 = e + \Delta e$$

e: Standard value in table 4 (0.012)

$\Delta e$ : Corrected value

$$\Delta e = \frac{L_1}{L} \cdot E_2$$

$E_2$ : Overall radial runout in respect to EF according to JIS.

$$= \frac{80}{500} \cdot 0.060 = 0.010$$

$$E_1 = 0.012 + 0.010 = 0.022$$

Notes: The overall runout of the thread root as seen in table 4 depends on the overall runout of the screw shaft.

Therefore, like in the example, the proportion between the screw shaft length L and the measurement point must be set.

Table 5 Perpendicularity of the screw shaft supported portion in respect to EF

Unit:  $\mu\text{m}$

Shaft diameter $d_0$ (mm)		Perpendicularity	
THK Accuracy grade		C3	C5
Over	Up to (incl.)		
12	20	4	5
20	32	4	5
32	50	4	5

Notes: For more detailed information see JIS B 1191 and JIS B 1192.

Table 6 Perpendicularity of the flange mounting surface in respect to G

Unit:  $\mu\text{m}$

Nut outer diameter (mm)		Perpendicularity	
THK Accuracy grade		C3	C5
Over	Up to (incl.)		
20	32	8	10
32	50	8	11
50	80	10	13
80	125	12	15

Notes: For more detailed information see JIS B 1191 and JIS B 1192.

Table 7 Radial runout of the nut circumference in respect to C

Unit:  $\mu\text{m}$

Nut outer diameter (mm)		Perpendicularity	
THK Accuracy grade		C3	C5
Over	Up to (incl.)		
20	32	10	12
32	50	12	15
50	80	15	19
80	125	20	27

Notes: For more detailed information see JIS B 1191 and JIS B 1192.

Table 8 Radial runout of the outer screw shaft diameter in respect to EF

Unit:  $\mu\text{m}$

THK Standard		Over	C3				C5			
Screw shaft outer diameter $d_0$ (mm)			12	20	32	50	12	20	32	50
		Up to (incl.)	20	32	50	80	20	32	50	80
Screw shaft overall length (mm)	Over	Up to (incl.)								
	—	125	20				35			
	125	200	25	20			40	35		
	200	315	30	30			45	40		
	315	400	40	35	25		55	45	35	
	400	500	50	40	30		60	50	45	35
	500	630	55	45	35	30	75	60	50	40
	630	800	70	55	40	35	90	70	55	45
	800	1000	95	65	50	40	120	85	65	50
	1000	1250	120	85	60	45	150	100	75	60
	1250	1600	160	110	75	55	190	130	95	70
	1600	2000		140	95	70		170	120	85
2000	2500			120	85			150	110	

Notes: For more detailed information see JIS B 1191 und JIS B 1192.

## Mounting Surface Accuracy Cp and Ct

The mounting surface for the accuracy grades Cp and Ct of the rolled precision ballscrews according to the standards DIN and ISO.

Only valid for the types EPA, EPB, EPC, EBA, EBB, EBC and BLK

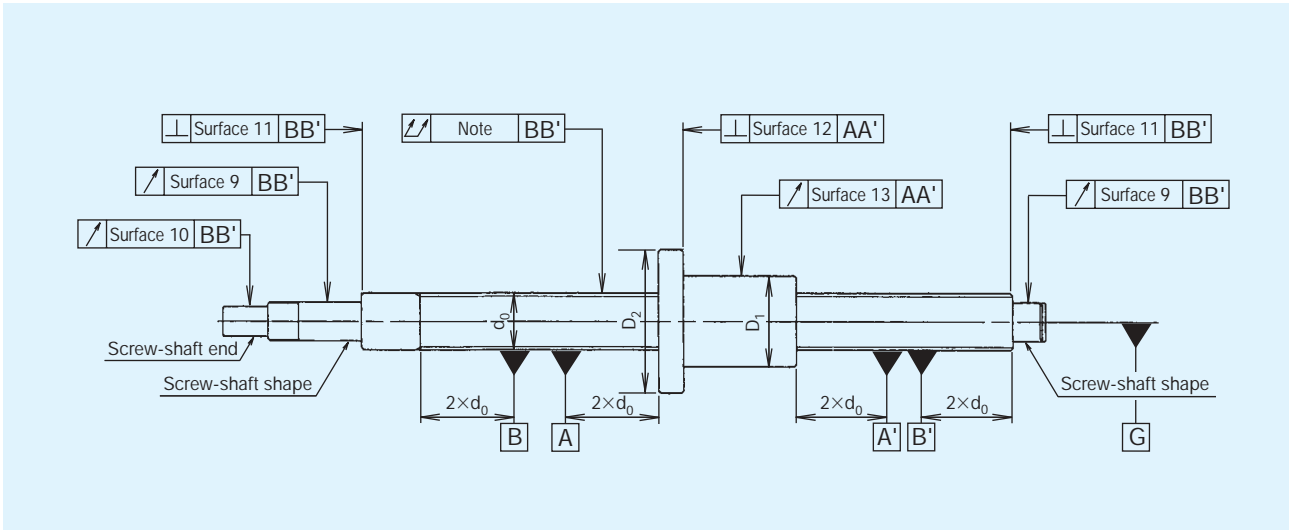

Table 9 Radial runout of the journal in respect to BB'

Unit:  $\mu\text{m}$

Nominal diameter $d_0$ (mm)		$\ell$ (mm)	Radial runout	
Over	Up to (incl.)		Cp3	Cp5/Ct5
6	20	80	12	20
20	50	125	16	25

Notes: For more detailed information and test instructions see DIN 69051, part 3.

Table 10 Coaxial deviation of the journal diameter in respect to the bearing diameter (D). Ballscrew is placed at the points BB'

Unit:  $\mu\text{m}$

Nominal diameter $d_0$ (mm)		$\ell$ (mm)	Coaxial deviation	
Over	Up to (incl.)		Cp3	Cp5/Ct5
6	20	80	6	8
20	50	125	8	10

Notes: For more detailed information and test instructions see DIN 69051, part 3.

Table 11 Axial runout of the bearing journal in respect to BB'

Unit:  $\mu\text{m}$

Nominal diameter $d_0$ (mm)		Axial runout	
Over	Up to (incl.)	Cp3	Cp5/Ct5
6	63	4	5

Notes: For more detailed information and test instructions see DIN 69051, part 3.

Table 11 Perpendicularity of the flange mounting surface in respect to AA'

Unit:  $\mu\text{m}$

Flange diameter $D_2$ (mm)		Perpendicularity	
Over	Up to (incl.)	Cp3	Cp5/Ct5
16	32	12	16
32	63	16	20
63	125	20	25
125	200	25	32

Notes: For more detailed information and test instructions see DIN 69051, part 3.

Table 13 Radial runout of the outer diameter of the nut in respect to AA'

Unit:  $\mu\text{m}$

Outer diameter $D_1$ (mm)		Runout	
Over	Up to (incl.)	Cp3	Cp5/Ct5
16	32	12	16
32	63	16	20
63	125	20	25
125	200	25	32

Notes: For more detailed information and test instructions see DIN 69051, part 3.

Table 14 Measurement of radial runout of the ballscrew shaft outer diameter for ascertaining straightness related to BB' per length  $\ell_5$

Unit:  $\mu\text{m}$

Screw shaft outer diameter $d_0$ (mm)		Reference length $\ell_5$ (mm)	Runout	
Over	Up to (incl.)		Cp3	Cp5/Ct5
12	25	160	25	32
25	50	315	25	32

Notes: For more detailed information and test instructions see DIN 69051, part 3.

Table 15 Maximum radial runout of the ballscrew shaft diameter valid for  $\ell_1 \geq 4\ell_5$

Unit:  $\mu\text{m}$

$\frac{\ell_1}{d_0}$		Runout (max)	
Over	Up to (incl.)	Cp3	Cp5/Ct5
—	40	50	64
40	60	75	96
60	80	125	160
80	100	200	256

$\ell_1$  = Effective screw shaft length [mm]

$d_0$  = Screw shaft outer diameter [mm]

$\ell_5$  = Reference length [mm]

Notes: For more detailed information and test instructions see DIN 69051, part 3.

# Preload and Rigidity

## Preload

The preload eliminates the axial clearance of the ballscrew and improves the rigidity. Furthermore, the preload ensures positioning accuracy.

### Preloading methods

(A) Pitch shift method: The pitch is shifted at the central part of the nut to create the requested preload.

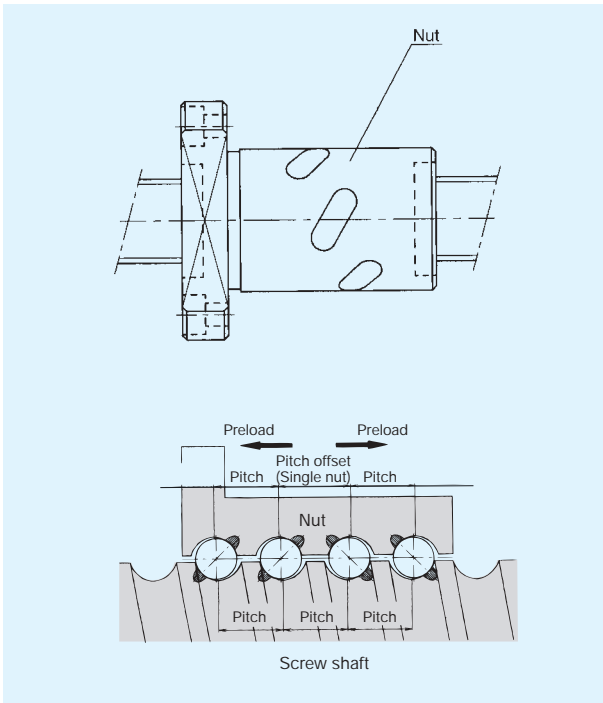

(B) Ball selection: To create the requested preload the nut is filled with balls in a certain diameter.

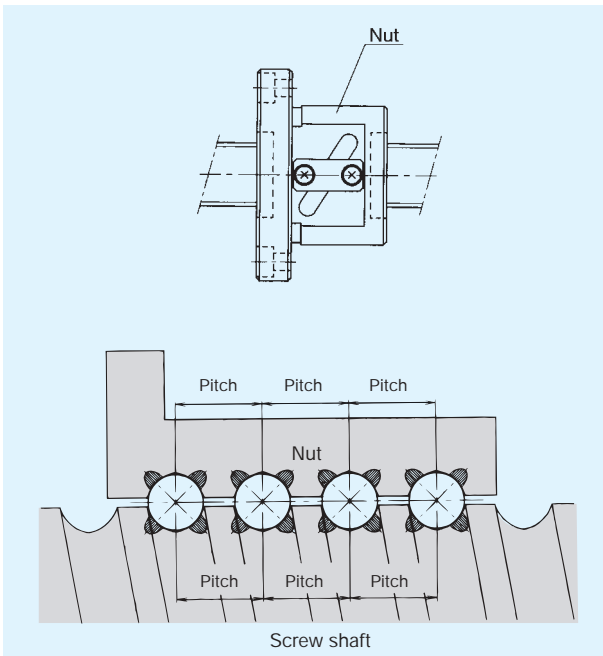

(C) Double nut method: Between two nuts a spacer creates the required preload.

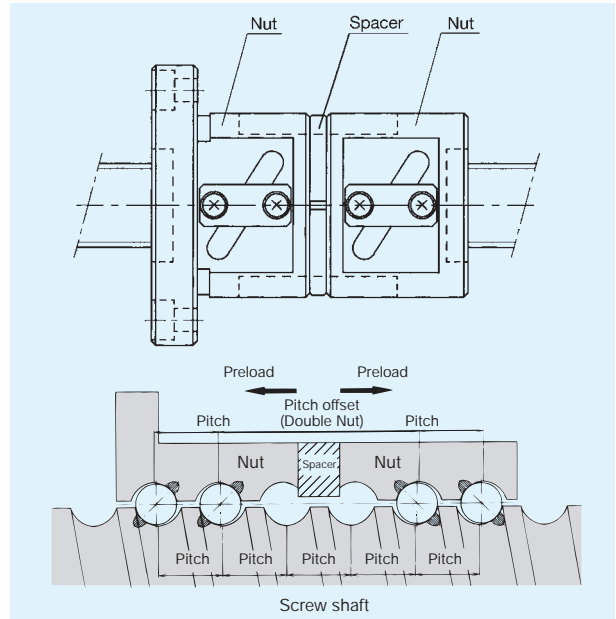

### Rigidity of the preloaded ballscrew

Nuts A and B of a double nut ballscrew receive preload  $F_{a0}$  as a result of the spacer. The preload causes elastic displacement  $\delta_{a0}$  to be applied to both nuts. If an axial load  $F_a$  is exerted from outside under these conditions, the displacements of both nuts become as follows:

$$\delta_a = \delta_{a0} + \delta_{a1} \quad \delta_b = \delta_{a0} - \delta_{a1}$$

That is, the loads exerted on nuts A and B are as follows:

$$F_A = F_{a0} + F_a - F_{a'} = F_a + F_p \quad F_B = F_{a0} - F_{a'} = F_p$$

Axial load and elastic displacement are connected as follows:

$$\delta_{a0} = K \cdot F_{a0}^{2/3} \quad 2 \delta_{a0} = K \cdot F_1^{2/3}$$

$$\left(\frac{F_1}{F_{a0}}\right)^{2/3} = \frac{2 \delta_{a0}}{\delta_{a0}} = 2 \quad F_t = 2.8 F_{a0} \approx 3 F_{a0}$$

The most optimum preload level is one-third of the maximum axial load. Standard values for the maximum axial load are mentioned on page 2. A too high preload shortens the life time and increases the heat development.

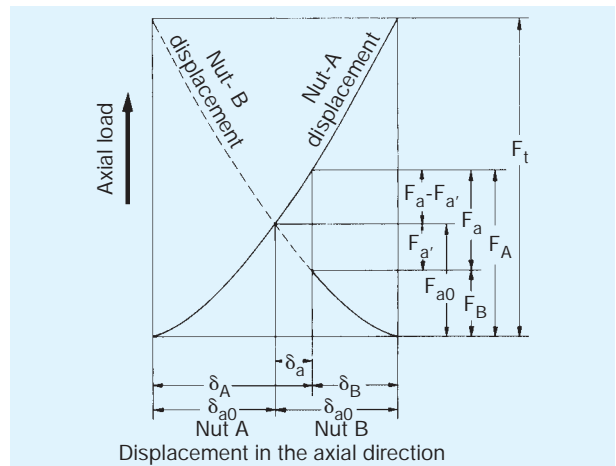



## Axial Rigidity of the Feed-Screw System

Let the axial rigidity of a feed-screw system be  $K$ . Then, the elastic displacement in the axial direction can be obtained using equation.

$$\delta = \frac{F_a}{K}$$

$\delta$  : Feed-screw system elastic displacement in the axial direction ( $\mu\text{m}$ )  
 $F_a$  : applied axial load (N)

The rigidity ( $K$ ) of this feed-screw system can be obtained using equation (30).

$$\frac{1}{K} = \frac{1}{K_S} + \frac{1}{K_N} + \frac{1}{K_B} + \frac{1}{K_H}$$

$K$  : axial rigidity of the feed-screw system (N/ $\mu\text{m}$ )  
 $K_S$  : axial rigidity of the screw shaft (N/ $\mu\text{m}$ )  
 $K_N$  : axial rigidity of the Nut (N/ $\mu\text{m}$ )  
 $K_B$  : axial rigidity of the support bearing (N/ $\mu\text{m}$ )  
 $K_H$  : rigidity of the Nut Bracket and support bearing bracket (N/ $\mu\text{m}$ )

### Axial rigidity of the screw shaft

The axial rigidity of a screw shaft varies depending on the shaft mounting method.

#### (1) For "fixed/supported" (free)

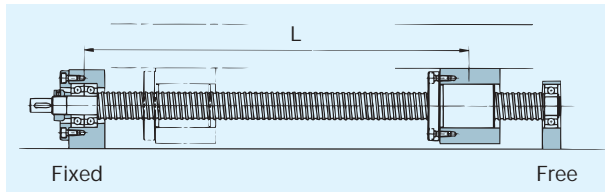

$$K_S = \frac{A \cdot E}{1000 \cdot L}$$

$A$  : screw-shaft cross-sectional area ( $\text{mm}^2$ )  
 $A = \frac{\pi}{4} d_1^2$   
 $(d_1$ : screw-shaft-thread minor diameter) (mm)  
 $E$  : Young's modulus ( $2.06 \cdot 10^5 \text{ N/mm}^2$ )  
 $L$  : distance between mounting positions (mm)

#### (2) For "fixed/fixe"

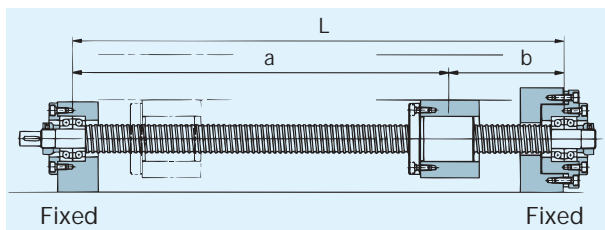

$$K_S = \frac{A \cdot E \cdot L}{1000 \cdot a \cdot b}$$

At the point at which  $a = b = \frac{L}{2}$

$K_S$  becomes the minimum and the elastic displacement in the axial direction the maximum.

$$K_S = \frac{4A \cdot E}{1000L}$$

### Axial rigidity of a nut

The axial rigidity of a Nut varies significantly depending on the preload levels.

Dimension tables include theoretical axial rigidity values when an axial load with a magnitude of 30% of the basic dynamic load rating ( $C_a$ ) is exerted on the Nut. These values, however, do not take into account the rigidity of the Nut mounting brackets. Therefore, as a general rule, take 80% of the values given in the table.

When the applied axial load with a magnitude other than 30% of the basic dynamic load rating ( $C_a$ ) is exerted on the Nut, rigidity values can be calculated using equation.

$$K_N = K \left( \frac{F_a}{0.3 C_a} \right)^{1/3} \cdot 0.8$$

where

$K_N$  : axial rigidity of the Nut (N/ $\mu\text{m}$ )  
 $K$  : rigidity value given in the dimension table (N/ $\mu\text{m}$ )  
 $F_a$  : applied axial load (N)  
 $C_a$  : basic dynamic load rating (N)

### Axial rigidity of the support bearing

The axial rigidity of the support bearings for the ballscrew varies by bearing type.

A typical calculation for determining the axial rigidity of an angular contact ball bearing can be made using equation.

$$K_B \approx \frac{3F_{a0}}{\delta_{a0}}$$

where

$K_B$  : axial rigidity of the support bearing (N/ $\mu\text{m}$ )  
 $F_{a0}$  : preload on the support bearing (N)  
 $\delta_{a0}$  : displacement in the axial direction ( $\mu\text{m}$ )

$$\delta_{a0} = \frac{0.45}{\sin \alpha} \left( \frac{Q^2}{D_a} \right)^{1/3}$$

$$Q = \frac{F_{a0}}{Z \sin \alpha}$$

where

$Q$  : axial load (N)  
 $D_a$  : ball diameter of the support bearing (mm)  
 $\alpha$  : initial contact angle of the support bearing ( $^\circ$ )  
 $Z$  : number of balls

If you are not certain of these values, please contact the manufacturer of the bearing to be used.

### Axial rigidity of the nut bracket and support bearing bracket

Take this into consideration in the design of your system. Set the rigidity as high as possible.

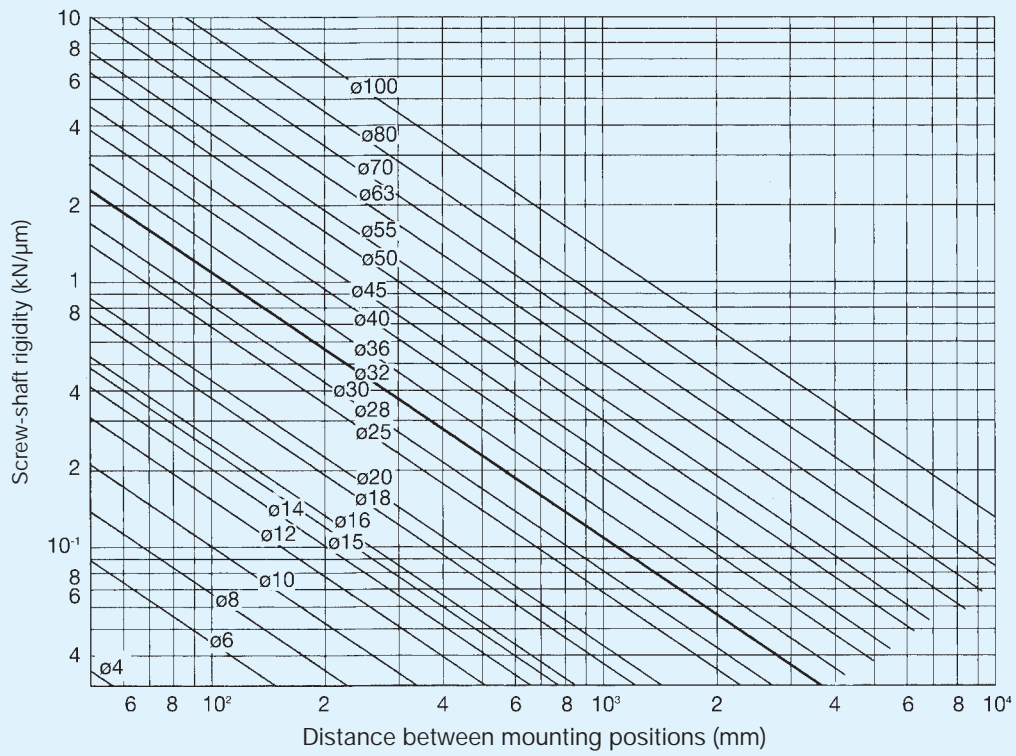

Axial Rigidity of a Screw Shaft („Fixed/Free“ and „Fixed/Supported“)

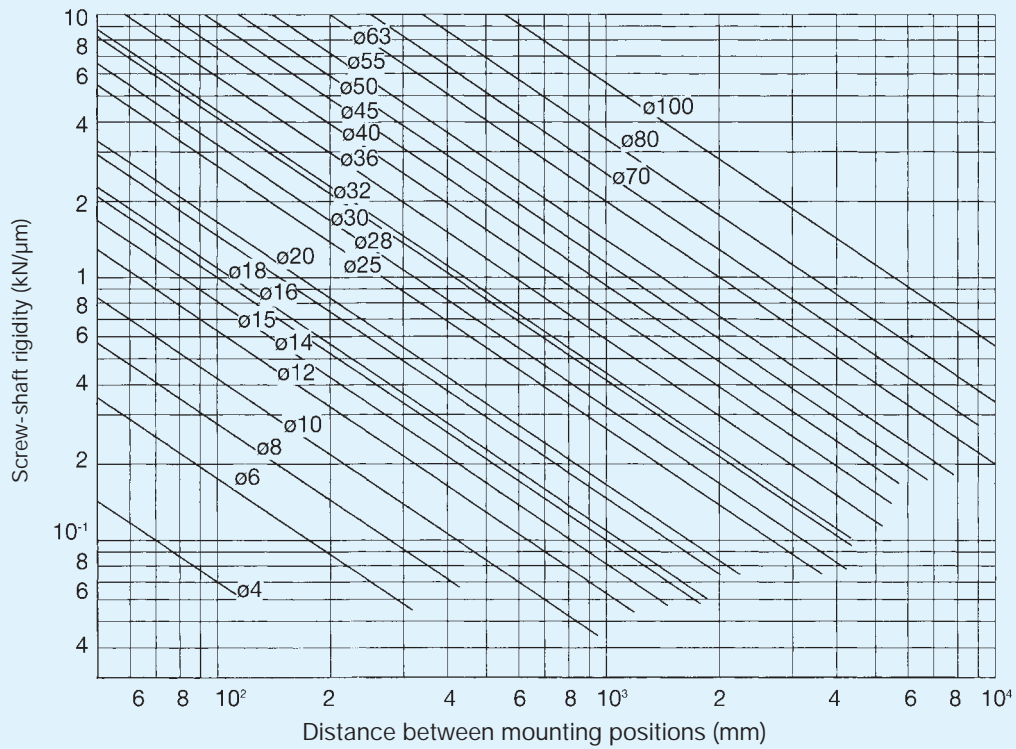

Axial Rigidity of a Screw Shaft („Fixed/Fixed“)

# Lubrication, Handling and Installation

## Lubrication

To ensure the optimum performance of the ballscrew, the correct lubricant and lubrication method for the relevant operating conditions should be selected.

For the classification and characteristics of lubricants and lubrication methods, see page A-7.

### Amount of lubricant

Insufficient lubricant causes poor lubrication, whereas an excessive amount of lubricant generates heat and increases resistance. It is therefore important to determine the optimum amount of lubricant for the relevant operating conditions.

### Grease

The appropriate amount of grease is normally approximately 1/3 of the volume of the space within the nut.

### Oil

Table 1 gives guidelines for the amount of oil. Please note, however, that the amount of oil depends on the stroke, type of oil used, and operating conditions (e.g., need to prevent heat generation).

Table 1 Guidelines for the amount of oil  
(Interval: 3 min.)

Shaft diameter (mm)	Amount of oil (cm <sup>3</sup> )
16 ~ 18	0.07
20 ~ 25	0.10
28 ~ 32	0.15
36 ~ 40	0.25

## Handling

As friction is reduced to a very low level in the ballscrew, when it is held upright, the nut can easily fall off the screw shaft.

Please be aware of this when holding the ballscrew upright. If the nut is not in place, the balls will also fall off, which may damage the ball circulation mechanism including the return pipe. Should the nut be detached from the screw shaft, contact **THK**.

Some ballscrews have exposed ball circulation mechanisms (return pipe, end cap), so be very careful to avoid dents and similar impacts.

## Contamination Protection

Dust and foreign matter that enter the ballscrew may cause accelerated wear and breakage, as with rolling bearings. Therefore, where contamination by dust and foreign matter (e.g., cutting chips) is likely, screw shafts must always be completely covered with contamination protection devices such as bellows or screw covers. If the ballscrew is used in an atmosphere free from foreign matter but with suspended dust, the labyrinth seal (for Precision Ballscrews) and brush seal (for Rolled Ballscrews) can be used in place of contamination protection devices. When placing an order, be sure to specify the model number.

The labyrinth seal is designed to maintain a clearance between the seal and screw-shaft raceway, so that torque does not develop and no heat is generated. However, its effect in contamination protection is limited.

In ballscrews other than the large-lead and super-lead types, there is no difference in nut dimensions between those with and without a seal.

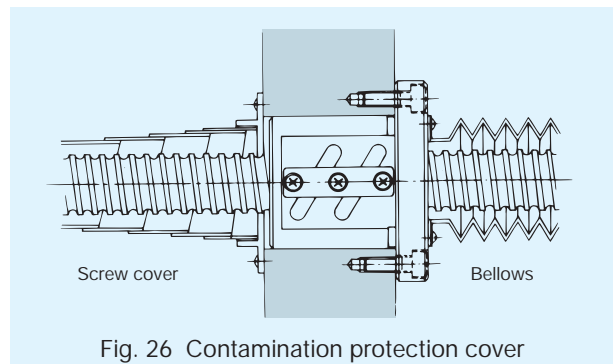

Fig. 26 Contamination protection cover

## Installation

When attaching the ballscrew to a machine, do not detach the nut from the screw shaft. If it is necessary to detach the nut, apply a sleeve with a bore approximately 1 mm smaller than the screw-shaft thread minor diameter so as to prevent balls from falling off. Although the thread of the ballscrew is hardened and finished by grinding, forcible driving of a part onto the screw shaft or into the nut may cause an indentation in the raceway. When assembling parts on the screw shaft and nut, take care not to apply excessive force to the shaft and nut.

Misalignment between the screw-shaft supported portion and the nut exerts an unnatural force on the ballscrew, resulting in problems such as heavy rotation. Similar symptoms appear when the nut and the shaft supported portion are tilted. These problems accelerate wear on the ballscrew, which may significantly decrease its service life. Therefore, in terms of the mounting accuracy, pay close attention to misalignment and tilt. Upon completion of mounting, the ballscrew must be checked by moving it over the entire stroke to ensure that there is no problem with its operation.

In designing your ballscrew system, make sure that no radial load or moment is exerted on the ballscrew. Remember that a radial load or moment may significantly decrease the service life and cause malfunctions.

## Precision Ballscrew EBA

- Single nut according to DIN 69051 (1989) with flange form A
- Preload by ball selection (ground) or without preload (precision rolled)
- Ground or precision rolled screw shafts available

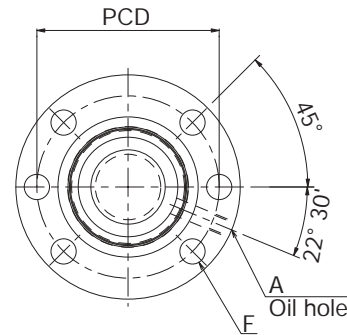
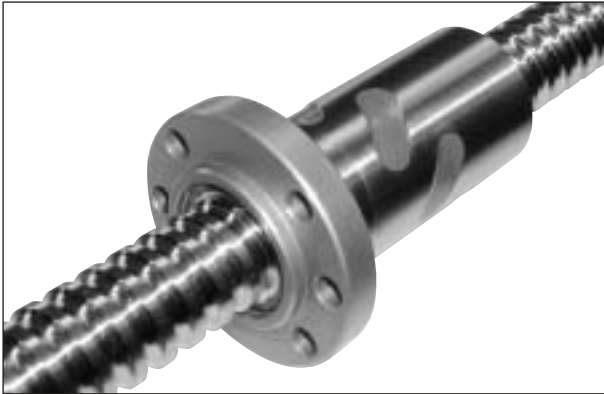

Drilling template 1

Model number	Screw shaft diameter d	Lead $\ell$	Ball center-to-center diameter dp	Thread minor diameter d <sub>3</sub>	No. of loaded circuits/rows × turns	Basic load rating		Rigidity <sup>1)</sup> K [N/μm]
						C <sub>a</sub> [kN]	C <sub>0a</sub> [kN]	
* EBA1605-4RR	16	5	16.75	13.4	4×1	10.2	17.0	237
* EBA2005-3RR	20	5	20.75	17.4	3×1	9.2	16.9	219
* EBA2505-3RR	25	5	25.75	22.4	3×1	10.5	22.2	266
* EBA2510-3RR	25	10	26	21.9	3×1	13.9	26.4	271
* EBA2510-4RR	25	10	26	21.9	4×1	17.7	35.2	356
* EBA3205-3RR	32	5	32.75	29.4	3×1	11.9	29.6	327
* EBA3205-4RR	32	5	32.75	29.4	4×1	15.3	39.5	430
* EBA3205-6RR	32	5	32.75	29.4	6×1	21.6	59.2	634
* EBA3210-3RR	32	10	33.75	27.2	3×1	27.9	51.0	345
* EBA3210-4RR	32	10	33.75	27.2	4×1	35.8	68.0	454
EBA4005-6RR	40	5	40.75	37.4	6×1	24.1	76.1	762
* EBA4010-3RR	40	10	41.75	35.2	3×1	32.4	67.8	421
* EBA4010-4RR	40	10	41.75	35.2	4×1	41.5	90.4	553
EBA4020-3RR	40	20	41.75	35.2	3×1	30.7	63.3	413
EBA5005-6RR	50	5	50.75	47.4	6×1	26.6	97.3	914
EBA5010-4RR	50	10	51.75	45.2	4×1	47.2	118.5	671
EBA5020-3RR	50	20	52.25	45.2	3×1	45.9	137.8	509
EBA6310-6RR	63	10	64.75	58.2	6×1	76.4	236.8	1217
EBA6320-3RR	63	20	65.7	56.0	3×1	80.2	212.0	673

\* Also available with precision rolled screw shaft (Cp3 und Cp5).

<sup>1)</sup> The rigidity values in this table indicate spring constants obtained from the load and elastic displacement under a preload of 10% of the basic dynamic load rating C<sub>a</sub>, and an axial load F<sub>a</sub> that is three times that of the preload F<sub>a0</sub>. As these values do not take into account the rigidity of the parts involved in the nut installation, take 80% of the values given in this table as a general guideline.

If the preload F<sub>a0</sub> differs from 0.1 C<sub>a</sub>, the rigidity K<sub>N</sub> can be calculated using the following equation:

$$K_N = K \cdot \left( \frac{F_{a0}}{0.1 C_a} \right)^{\frac{1}{3}} \cdot 0.8$$

If the ballscrew is not preloaded, please consult **THK** for the rigidity value.

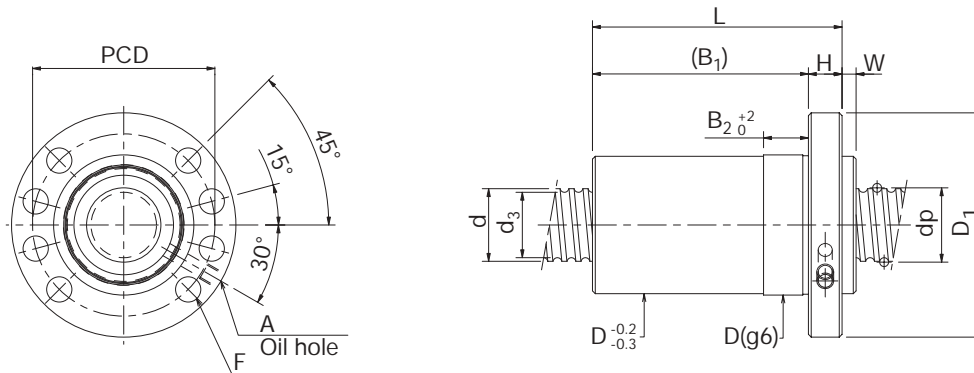

Drilling template 2

Unit: mm

Nut dimensions										Drilling template	Oil hole A	Screw shaft inertial moment per mm [kg·cm <sup>2</sup> /mm]
Outer diameter D	Flange diameter D <sub>1</sub>	Overall length L	H	B <sub>1</sub>	B <sub>2</sub>	W	PCD	F				
28	48	50	10	40	10	5	38	5.5	1	M6×1	5.05×10 <sup>-4</sup>	
36	58	45	10	35	10	5	47	6.6	1	M6×1	1.23×10 <sup>-3</sup>	
40	62	45	10	35	10	5	51	6.6	1	M6×1	3.01×10 <sup>-3</sup>	
40	62	75	10	65	16	5	51	6.6	1	M6×1	3.01×10 <sup>-3</sup>	
40	62	80	10	70	16	5	51	6.6	1	M6×1	3.01×10 <sup>-3</sup>	
50	80	47	12	35	10	5	65	9	1	M6×1	8.08×10 <sup>-3</sup>	
50	80	52	12	40	10	5	65	9	1	M6×1	8.08×10 <sup>-3</sup>	
50	80	62	12	50	10	5	65	9	1	M6×1	8.08×10 <sup>-3</sup>	
50	80	77	12	65	16	5	65	9	1	M6×1	8.08×10 <sup>-3</sup>	
50	80	89	12	77	16	5	65	9	1	M6×1	8.08×10 <sup>-3</sup>	
63	93	65	14	51	10	5	78	9	2	M6×1	1.97×10 <sup>-2</sup>	
63	93	79	14	65	16	5	78	9	2	M6×1	1.97×10 <sup>-2</sup>	
63	93	89	14	75	16	5	78	9	2	M6×1	1.97×10 <sup>-2</sup>	
63	93	119	14	105	25	10	78	9	2	M6×1	1.97×10 <sup>-2</sup>	
75	110	70	16	54	10	5	93	11	2	M6×1	4.82×10 <sup>-2</sup>	
75	110	91	16	75	16	5	93	11	2	M6×1	4.82×10 <sup>-2</sup>	
75	110	124	16	108	25	10	93	11	2	M6×1	4.82×10 <sup>-2</sup>	
90	125	114	18	96	16	5	108	11	2	M6×1	1.21×10 <sup>-1</sup>	
95	135	126	18	108	25	10	115	13.5	2	M6×1	1.21×10 <sup>-1</sup>	

### Model-Number Coding

**EBA 32 05 – 4 RR G0 + 1200L Cp5**

(1) (2) (3) (4) (5) (6) (7) (8)

- (1) Nut
- (2) Screw shaft outer diameter (mm)
- (3) Lead (mm)
- (4) Number of circuits (rows × turns)
- (5) Seals (RR: labyrinth seals attached to both sides)

- (6) Symbol for preload  
G0 = preloaded  
GT = without clearance
- (7) Screw shaft total length (mm)
- (8) Accuracy (see page 10 - 15)

## Precision Ballscrew EBB

- Single nut according to DIN 69051 (1989) with flange form B
- Preload by ball selection (ground) or without preload (precision rolled)
- Ground or precision rolled screw shafts available

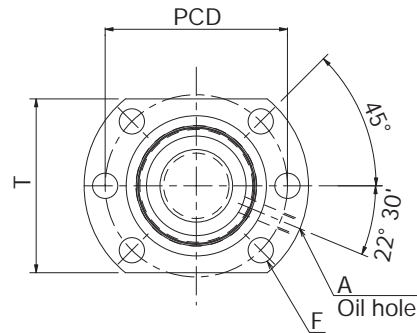
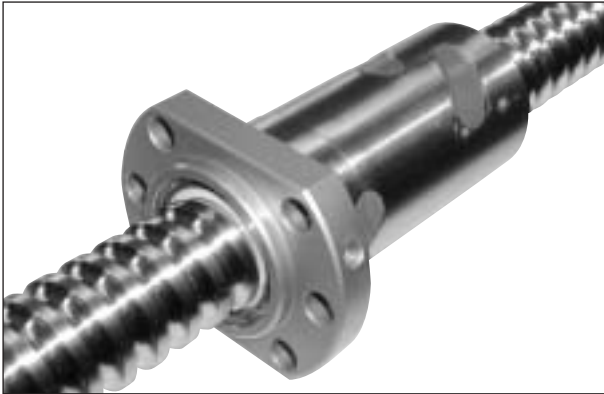

Drilling template 1

Model number	Screw shaft diameter d	Lead ℓ	Ball center-to-center diameter dp	Thread minor diameter d <sub>3</sub>	No. of loaded circuits/rows × turns	Basic load rating		Rigidity <sup>1)</sup> K [N/μm]
						C <sub>a</sub> [kN]	C <sub>0a</sub> [kN]	
* EBB1605-4RR	16	5	16.75	13.5	4×1	10.2	17.0	237
* EBB2005-3RR	20	5	20.75	17.5	3×1	9.2	16.9	219
* EBB2505-3RR	25	5	25.75	22.5	3×1	10.5	22.2	266
* EBB2510-3RR	25	10	26	21.9	3×1	13.9	26.4	271
* EBB2510-4RR	25	10	26	21.9	4×1	17.7	35.2	356
* EBB3205-3RR	32	5	32.75	29.5	3×1	11.9	29.6	327
* EBB3205-4RR	32	5	32.75	29.5	4×1	15.3	39.5	430
* EBB3205-6RR	32	5	32.75	29.5	6×1	21.6	59.2	634
* EBB3210-3RR	32	10	33.75	27.2	3×1	27.9	51.0	345
* EBB3210-4RR	32	10	33.75	27.2	4×1	35.8	68.0	454
EBB4005-6RR	40	5	40.75	37.5	6×1	24.1	76.1	762
* EBB4010-3RR	40	10	41.75	35.2	3×1	32.4	67.8	421
* EBB4010-4RR	40	10	41.75	35.2	4×1	41.5	90.4	553
* EBB4020-3RR	40	20	41.75	35.2	3×1	30.7	63.3	413
EBB5005-6RR	50	5	50.75	47.5	6×1	26.6	97.3	914
EBB5010-4RR	50	10	51.75	45.2	4×1	47.2	118.5	671
EBB5020-3RR	50	20	52.25	45.2	3×1	45.9	137.8	509
EBB6310-6RR	63	10	64.75	58.2	6×1	76.4	236.8	1217
EBB6320-3RR	63	20	65.7	56.0	3×1	80.2	212.0	673

\* Also available with precision rolled screw shaft (Cp3 und Cp5).

<sup>1)</sup> The rigidity values in this table indicate spring constants obtained from the load and elastic displacement under a preload of 10% of the basic dynamic load rating C<sub>a</sub>, and an axial load F<sub>a</sub> that is three times that of the preload F<sub>a0</sub>. As these values do not take into account the rigidity of the parts involved in the nut installation, take 80% of the values given in this table as a general guideline.

If the preload F<sub>a0</sub> differs from 0.1 C<sub>a</sub>, the rigidity K<sub>N</sub> can be calculated using the following equation:

$$K_N = K \cdot \left( \frac{F_{a0}}{0.1 C_a} \right)^{\frac{1}{3}} \cdot 0.8$$

If the ballscrew is not preloaded, please consult **THK** for the rigidity value.

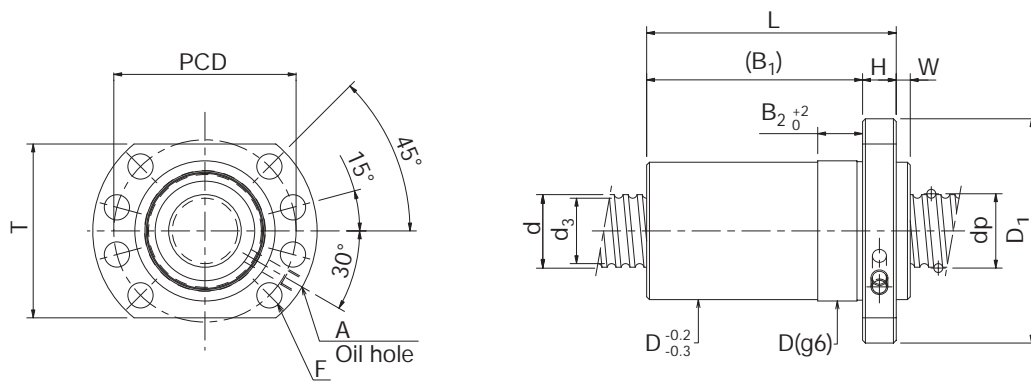

Drilling template 2

Unit: mm

Nut dimensions											Drilling template	Oil hole A	Screw shaft inertial moment per mm [kg·cm <sup>2</sup> /mm]
Outer diameter D	Flange diameter D <sub>1</sub>	Overall length L	H	B <sub>1</sub>	B <sub>2</sub>	W	T	PCD	F				
28	48	50	10	40	10	5	40	38	5.5	1	M6×1	5.05×10 <sup>-4</sup>	
36	58	45	10	35	10	5	44	47	6.6	1	M6×1	1.23×10 <sup>-3</sup>	
40	62	45	10	35	10	5	48	51	6.6	1	M6×1	3.01×10 <sup>-3</sup>	
40	62	75	10	65	16	5	48	51	6.6	1	M6×1	3.01×10 <sup>-3</sup>	
40	62	80	10	70	16	5	48	51	6.6	1	M6×1	3.01×10 <sup>-3</sup>	
50	80	47	12	35	10	5	62	65	9	1	M6×1	8.08×10 <sup>-3</sup>	
50	80	52	12	40	10	5	62	65	9	1	M6×1	8.08×10 <sup>-3</sup>	
50	80	62	12	50	10	5	62	65	9	1	M6×1	8.08×10 <sup>-3</sup>	
50	80	77	12	65	16	5	62	65	9	1	M6×1	8.08×10 <sup>-3</sup>	
50	80	89	12	77	16	5	62	65	9	1	M6×1	8.08×10 <sup>-3</sup>	
63	93	65	14	51	10	5	70	78	9	2	M6×1	1.97×10 <sup>-2</sup>	
63	93	79	14	65	16	5	70	78	9	2	M6×1	1.97×10 <sup>-2</sup>	
63	93	89	14	75	16	5	70	78	9	2	M6×1	1.97×10 <sup>-2</sup>	
63	93	119	14	105	25	10	70	78	9	2	M6×1	1.97×10 <sup>-2</sup>	
75	110	70	16	54	10	5	85	93	11	2	M6×1	4.82×10 <sup>-2</sup>	
75	110	91	16	75	16	5	85	93	11	2	M6×1	4.82×10 <sup>-2</sup>	
75	110	124	16	108	25	10	85	93	11	2	M6×1	4.82×10 <sup>-2</sup>	
90	125	114	18	96	16	5	95	108	11	2	M6×1	1.21×10 <sup>-1</sup>	
95	135	126	18	108	25	10	100	115	13.5	2	M6×1	1.21×10 <sup>-1</sup>	

### Model-Number Coding

**EBB 32 05 – 4 RR G0 + 1200L Cp5**

(1) (2) (3) (4) (5) (6) (7) (8)

- (1) Nut
- (2) Screw shaft outer diameter (mm)
- (3) Lead (mm)
- (4) Number of circuits (rows × turns)
- (5) Seals (RR: labyrinth seals attached to both sides)

- (6) Symbol for preload  
G0 = preloaded  
GT = without clearance
- (7) Screw shaft total length (mm)
- (8) Accuracy (see page 10 - 15)

## Precision Ballscrew EBC

- Single nut according to DIN 69051 (1989) with flange form C
- Preload by ball selection (ground) or without preload (precision rolled)
- Ground or precision rolled screw shafts available

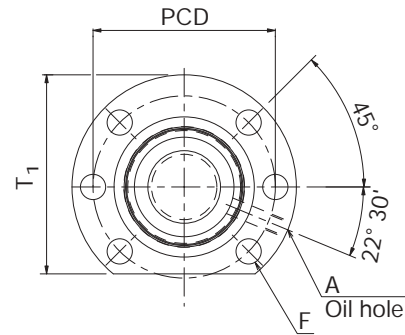
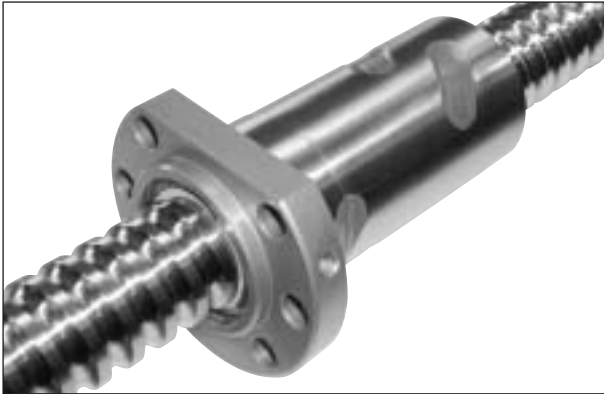

Drilling template 1

Model number	Screw shaft diameter d	Lead $\ell$	Ball center-to-center diameter dp	Thread minor diameter d <sub>3</sub>	No. of loaded circuits/rows × turns	Basic load rating		Rigidity <sup>1)</sup> K [N/μm]
						C <sub>a</sub> [kN]	C <sub>0a</sub> [kN]	
* EBC1605-4RR	16	5	16.75	13.5	4×1	10.2	17.0	237
* EBC2005-3RR	20	5	20.75	17.5	3×1	9.2	16.9	219
* EBC2505-3RR	25	5	25.75	22.5	3×1	10.5	22.2	266
* EBC2510-3RR	25	10	26	21.9	3×1	13.9	26.4	271
* EBC2510-4RR	25	10	26	21.9	4×1	17.7	35.2	356
* EBC3205-3RR	32	5	32.75	29.5	3×1	11.9	29.6	327
* EBC3205-4RR	32	5	32.75	29.5	4×1	15.3	39.5	430
* EBC3205-6RR	32	5	32.75	29.5	6×1	21.6	59.2	634
* EBC3210-3RR	32	10	33.75	27.2	3×1	27.9	51.0	345
* EBC3210-4RR	32	10	33.75	27.2	4×1	35.8	68.0	454
EBC4005-6RR	40	5	40.75	37.5	6×1	24.1	76.1	762
* EBC4010-3RR	40	10	41.75	35.2	3×1	32.4	67.8	421
* EBC4010-4RR	40	10	41.75	35.2	4×1	41.5	90.4	553
* EBC4020-3RR	40	20	41.75	35.2	3×1	30.7	63.3	413
EBC5005-6RR	50	5	50.75	47.5	6×1	26.6	97.3	914
EBC5010-4RR	50	10	51.75	45.2	4×1	47.2	118.5	671
EBC5020-3RR	50	20	52.25	45.2	3×1	45.9	137.8	509
EBC6310-6RR	63	10	64.75	58.2	6×1	76.4	236.8	1217
EBC6320-3RR	63	20	65.7	56.0	3×1	80.2	212.0	673

\* Also available with precision rolled screw shaft (Cp3 und Cp5).

<sup>1)</sup> The rigidity values in this table indicate spring constants obtained from the load and elastic displacement under a preload of 10% of the basic dynamic load rating C<sub>a</sub>, and an axial load F<sub>a</sub> that is three times that of the preload F<sub>a0</sub>. As these values do not take into account the rigidity of the parts involved in the nut installation, take 80% of the values given in this table as a general guideline.

If the preload F<sub>a0</sub> differs from 0.1 C<sub>a</sub>, the rigidity K<sub>N</sub> can be calculated using the following equation:

$$K_N = K \cdot \left( \frac{F_{a0}}{0.1 C_a} \right)^{\frac{1}{3}} \cdot 0.8$$

If the ballscrew is not preloaded, please consult **THK** for the rigidity value.



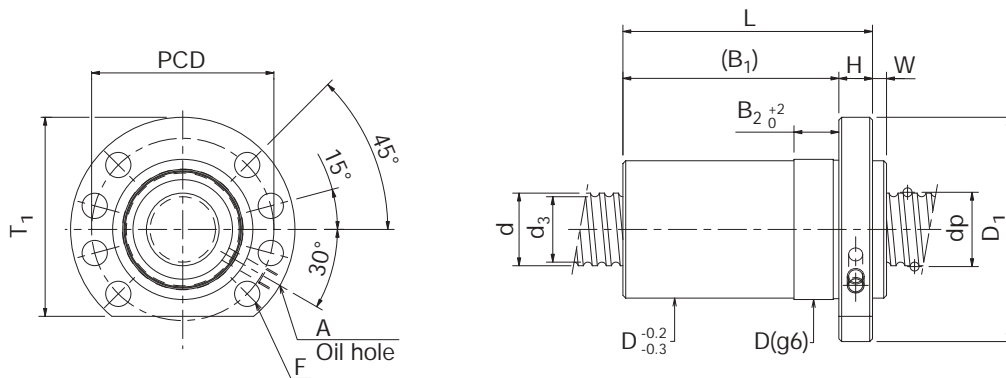

Drilling template 2

Unit: mm

Nut dimensions											Drilling template	Oil hole A	Screw shaft inertial moment per mm [kg·cm <sup>2</sup> /mm]
Outer diameter D	Flange diameter D <sub>1</sub>	Overall length L	H	B <sub>1</sub>	B <sub>2</sub>	W	T <sub>1</sub>	PCD	F				
28	48	50	10	40	10	5	44	38	5.5	1	M6×1	5.05×10 <sup>-4</sup>	
36	58	45	10	35	10	5	51	47	6.6	1	M6×1	1.23×10 <sup>-3</sup>	
40	62	45	10	35	10	5	55	51	6.6	1	M6×1	3.01×10 <sup>-3</sup>	
40	62	75	10	65	16	5	55	51	6.6	1	M6×1	3.01×10 <sup>-3</sup>	
40	62	80	10	70	16	5	55	51	6.6	1	M6×1	3.01×10 <sup>-3</sup>	
50	80	47	12	35	10	5	71	65	9	1	M6×1	8.08×10 <sup>-3</sup>	
50	80	52	12	40	10	5	71	65	9	1	M6×1	8.08×10 <sup>-3</sup>	
50	80	62	12	50	10	5	71	65	9	1	M6×1	8.08×10 <sup>-3</sup>	
50	80	77	12	65	16	5	71	65	9	1	M6×1	8.08×10 <sup>-3</sup>	
50	80	89	12	77	16	5	71	65	9	1	M6×1	8.08×10 <sup>-3</sup>	
63	93	65	14	51	10	5	81.5	78	9	2	M6×1	1.97×10 <sup>-2</sup>	
63	93	79	14	65	16	5	81.5	78	9	2	M6×1	1.97×10 <sup>-2</sup>	
63	93	89	14	75	16	5	81.5	78	9	2	M6×1	1.97×10 <sup>-2</sup>	
63	93	119	14	105	25	10	81.5	78	9	2	M6×1	1.97×10 <sup>-2</sup>	
75	110	70	16	54	10	5	97.5	93	11	2	M6×1	4.82×10 <sup>-2</sup>	
75	110	91	16	75	16	5	97.5	93	11	2	M6×1	4.82×10 <sup>-2</sup>	
75	110	124	16	108	25	10	97.5	93	11	2	M6×1	4.82×10 <sup>-2</sup>	
90	125	114	18	96	16	5	104.5	108	11	2	M6×1	1.21×10 <sup>-1</sup>	
95	135	126	18	108	25	10	117.5	115	13.5	2	M6×1	1.21×10 <sup>-1</sup>	

### Model-Number Coding

**EBC 32 05 – 4 RR G0 + 1200L Cp5**

- (1) Nut  
 (2) Screw shaft outer diameter (mm)  
 (3) Lead (mm)  
 (4) Number of circuits (rows × turns)  
 (5) Seals (RR: labyrinth seals attached to both sides)

- (6) Symbol for preload  
 G0 = preloaded  
 GT = without clearance  
 (7) Screw shaft total length (mm)  
 (8) Accuracy (see page 10 - 15)

## Precision Ballscrew EPA

- Single nut according to DIN 69051 (1989) with flange form A
- Type EPA: Preload by pitch shifting
- Ground or precision rolled screw shafts available

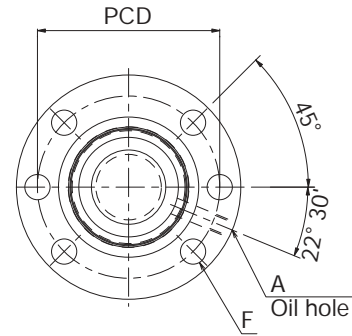
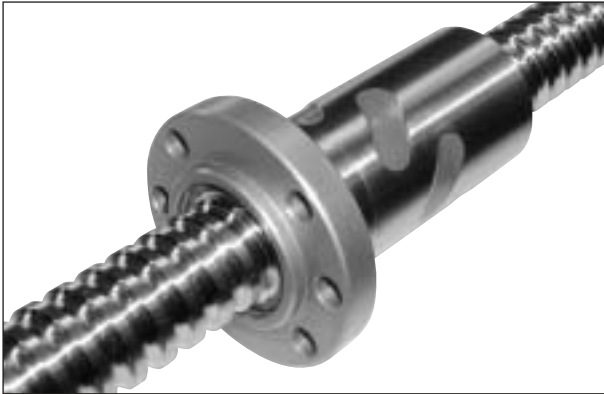

Drilling template 1

Model number	Screw shaft diameter d	Lead $\ell$	Ball center-to-center diameter dp	Thread minor diameter d <sub>3</sub>	No. of loaded circuits/rows × turns	Basic load rating		Rigidity <sup>1)</sup> K [N/μm]
						C <sub>a</sub> [kN]	C <sub>0a</sub> [kN]	
* EPA1605-6RR	16	5	16.75	13.5	3×1	7.9	12.7	360
* EPA2005-6RR	20	5	20.75	17.5	3×1	9.2	16.9	439
* EPA2505-6RR	25	5	25.75	22.5	3×1	10.5	22.2	532
* EPA2510-4RR	25	10	26	21.9	2×1	9.8	17.6	369
* EPA3205-6RR	32	5	32.75	29.5	3×1	11.9	29.6	655
* EPA3205-8RR	32	5	32.75	29.5	4×1	15.3	39.5	862
* EPA3210-6RR	32	10	33.75	27.2	3×1	27.9	51.0	691
EPA4005-6RR	40	5	40.75	37.5	3×1	13.3	38.1	788
* EPA4010-6RR	40	10	41.75	35.2	3×1	32.4	67.8	842
* EPA4010-8RR	40	10	41.75	35.2	4×1	41.5	90.4	1108
EPA5005-6RR	50	5	50.75	47.5	3×1	14.6	48.7	945
EPA5005-12RR	50	5	50.75	47.5	6×1	26.6	97.3	1830
EPA5010-8RR	50	10	51.75	45.2	4×1	47.2	118.5	1342
EPA6310-8RR	63	10	64.7	58.2	4×1	53.9	157.8	1654

\* Also available with precision rolled screw shaft (Cp3 und Cp5).

<sup>1)</sup> The rigidity values in this table indicate spring constants obtained from the load and elastic displacement under a preload of 10% of the basic dynamic load rating C<sub>a</sub>, and an axial load F<sub>a</sub> that is three times that of the preload F<sub>a0</sub>. As these values do not take into account the rigidity of the parts involved in the nut installation, take 80% of the values given in this table as a general guideline.

If the preload F<sub>a0</sub> differs from 0.1 C<sub>a</sub>, the rigidity K<sub>N</sub> can be calculated using the following equation:

$$K_N = K \cdot \left( \frac{F_{a0}}{0.1 C_a} \right)^{\frac{1}{3}} \cdot 0.8$$

If the ballscrew is not preloaded, please consult **THK** for the rigidity value.

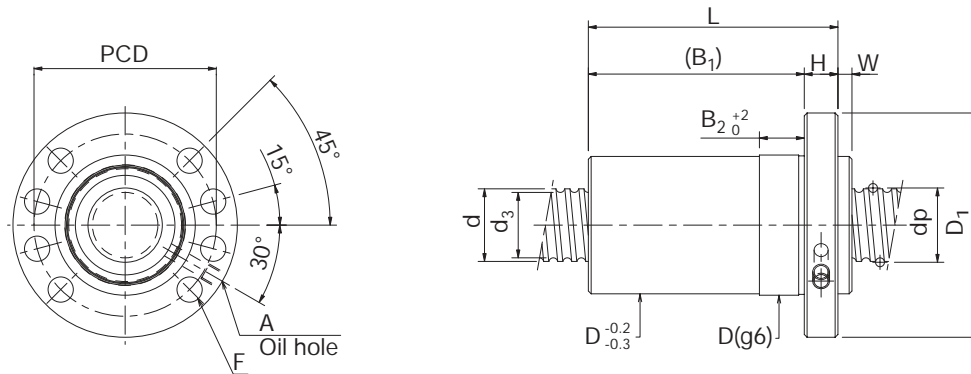

Drilling template 2

Unit: mm

Outer diameter D	Flange diameter D <sub>1</sub>	Overall length L	Nut dimensions						Drilling template	Oil hole A	Screw shaft inertial moment per mm [kg·cm <sup>2</sup> /mm]
			H	B <sub>1</sub>	B <sub>2</sub>	W	PCD	F			
28	48	60	10	50	10	5	38	5.5	1	M6×1	5.05×10 <sup>-4</sup>
36	58	61	10	51	10	5	47	6.6	1	M6×1	1.23×10 <sup>-3</sup>
40	62	61	10	51	10	5	51	6.6	1	M6×1	3.01×10 <sup>-3</sup>
40	62	80	10	70	16	5	51	6.6	1	M6×1	3.01×10 <sup>-3</sup>
50	80	62	12	50	10	5	65	9	1	M6×1	8.08×10 <sup>-3</sup>
50	80	73	12	61	10	5	65	9	1	M6×1	8.08×10 <sup>-3</sup>
50	80	107	12	95	10	5	65	9	1	M6×1	8.08×10 <sup>-3</sup>
63	93	65	14	51	10	5	78	9	2	M6×1	1.97×10 <sup>-2</sup>
63	93	109	14	95	16	5	78	9	2	M6×1	1.97×10 <sup>-2</sup>
63	93	133	14	119	16	5	78	9	2	M6×1	1.97×10 <sup>-2</sup>
75	110	70	16	54	10	5	93	11	2	M6×1	4.82×10 <sup>-2</sup>
75	110	105	16	89	10	5	93	11	2	M6×1	4.82×10 <sup>-2</sup>
75	110	135	16	119	16	5	93	11	2	M6×1	4.82×10 <sup>-2</sup>
90	125	137	18	119	16	5	108	11	2	M6×1	1.21×10 <sup>-1</sup>

### Model-Number Coding

**EPA 32 05 – 4 RR G0 + 1200L Cp5**

(1) (2) (3) (4) (5) (6) (7) (8)

(1) Nut

(2) Screw shaft outer diameter (mm)

(3) Lead (mm)

(4) Number of circuits (rows × turns)

(5) Seals (RR: labyrinth seals attached to both sides)

(6) Preload

(7) Screw shaft total length (mm)

(8) Accuracy (see page 10 - 15)

## Precision Ballscrew EPB

- Single nut according to DIN 69051 (1989) with flange form B
- Type EPB: Preload by pitch shifting
- Ground or precision rolled screw shafts available

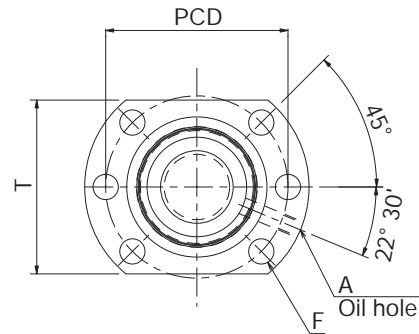
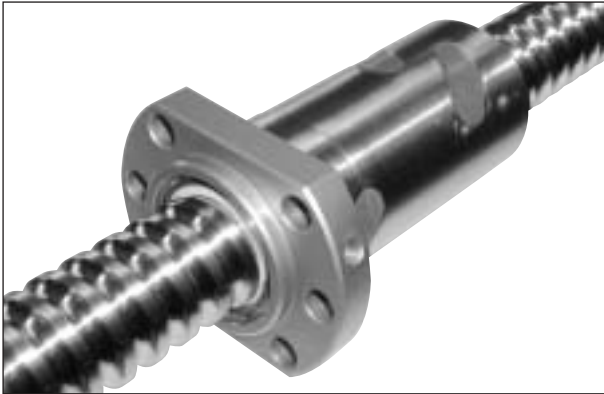

Drilling template 1

Model number	Screw shaft diameter d	Lead $\ell$	Ball center-to-center diameter dp	Thread minor diameter d <sub>3</sub>	No. of loaded circuits/rows × turns	Basic load rating		Rigidity <sup>1)</sup> K [N/μm]
						C <sub>a</sub> [kN]	C <sub>0a</sub> [kN]	
* EPB1605-6RR	16	5	16.75	13.5	3×1	7.9	12.7	360
* EPB2005-6RR	20	5	20.75	17.5	3×1	9.2	16.9	439
* EPB2505-6RR	25	5	25.75	22.5	3×1	10.5	22.2	532
* EPB2510-4RR	25	10	26	21.9	2×1	9.8	17.6	369
* EPB3205-6RR	32	5	32.75	29.5	3×1	11.9	29.6	655
* EPB3205-8RR	32	5	32.75	29.5	4×1	15.3	39.5	862
* EPB3210-6RR	32	10	33.75	27.2	3×1	27.9	51.0	691
EPB4005-6RR	40	5	40.75	37.5	3×1	13.3	38.1	788
* EPB4010-6RR	40	10	41.75	35.2	3×1	32.4	67.8	842
* EPB4010-8RR	40	10	41.75	35.2	4×1	41.5	90.4	1108
EPB5005-6RR	50	5	50.75	47.5	3×1	14.6	48.7	945
EPB5005-12RR	50	5	50.75	47.5	6×1	26.6	97.3	1830
EPB5010-8RR	50	10	51.75	45.2	4×1	47.2	118.5	1342
EPB6310-8RR	63	10	64.7	58.2	4×1	53.9	157.8	1654

\* Also available with precision rolled screw shaft (Cp3 und Cp5).

<sup>1)</sup> The rigidity values in this table indicate spring constants obtained from the load and elastic displacement under a preload of 10% of the basic dynamic load rating C<sub>a</sub>, and an axial load F<sub>a</sub> that is three times that of the preload F<sub>a0</sub>. As these values do not take into account the rigidity of the parts involved in the nut installation, take 80% of the values given in this table as a general guideline.

If the preload F<sub>a0</sub> differs from 0.1 C<sub>a</sub>, the rigidity K<sub>N</sub> can be calculated using the following equation:

$$K_N = K \cdot \left( \frac{F_{a0}}{0.1 C_a} \right)^{\frac{1}{3}} \cdot 0.8$$

If the ballscrew is not preloaded, please consult **THK** for the rigidity value.

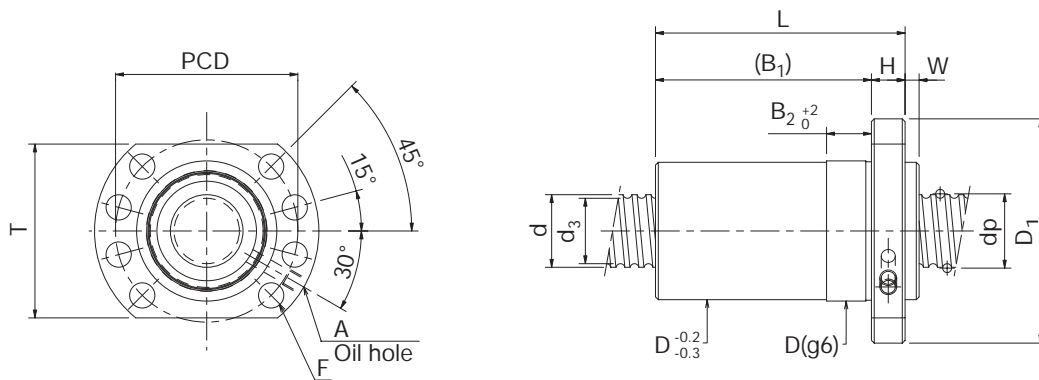

Drilling template 2

Unit: mm

Nut dimensions												Screw shaft inertial moment per mm [kg·cm <sup>2</sup> /mm]
Outer diameter D	Flange diameter D <sub>1</sub>	Overall length L	H	B <sub>1</sub>	B <sub>2</sub>	W	T	PCD	F	Drilling template	Oil hole A	
28	48	60	10	50	10	5	40	38	5.5	1	M6×1	5.05×10 <sup>-4</sup>
36	58	61	10	51	10	5	44	47	6.6	1	M6×1	1.23×10 <sup>-3</sup>
40	62	61	10	51	10	5	48	51	6.6	1	M6×1	3.01×10 <sup>-3</sup>
40	62	80	10	70	16	5	48	51	6.6	1	M6×1	3.01×10 <sup>-3</sup>
50	80	62	12	50	10	5	62	65	9	1	M6×1	8.08×10 <sup>-3</sup>
50	80	73	12	61	10	5	62	65	9	1	M6×1	8.08×10 <sup>-3</sup>
50	80	107	12	95	10	5	62	65	9	1	M6×1	8.08×10 <sup>-3</sup>
63	93	65	14	51	10	5	70	78	9	2	M6×1	1.97×10 <sup>-2</sup>
63	93	109	14	95	16	5	70	78	9	2	M6×1	1.97×10 <sup>-2</sup>
63	93	133	14	119	16	5	70	78	9	2	M6×1	1.97×10 <sup>-2</sup>
75	110	70	16	54	10	5	85	93	11	2	M6×1	4.82×10 <sup>-2</sup>
75	110	105	16	89	10	5	85	93	11	2	M6×1	4.82×10 <sup>-2</sup>
75	110	135	16	119	16	5	85	93	11	2	M6×1	4.82×10 <sup>-2</sup>
90	125	137	18	119	16	5	95	108	11	2	M6×1	1.21×10 <sup>-1</sup>

### Model-Number Coding

**EPB 32 05 – 4 RR G0 + 1200L Cp5**

(1) (2) (3) (4) (5) (6) (7) (8)

(1) Nut

(2) Screw shaft outer diameter (mm)

(3) Lead (mm)

(4) Number of circuits (rows × turns)

(5) Seals (RR: labyrinth seals attached to both sides)

(6) Preload

(7) Screw shaft total length (mm)

(8) Accuracy (see page 10 - 15)

## Precision Ballscrew EPC

- Single nut according to DIN 69051 (1989) with flange form C
- Type EPC: Preload by pitch shifting
- Ground or precision rolled screw shafts available

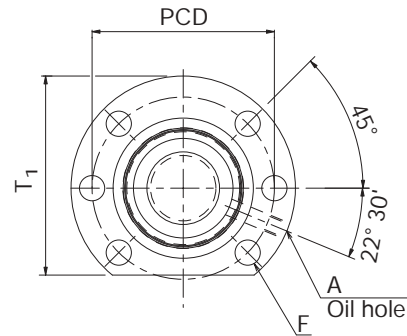
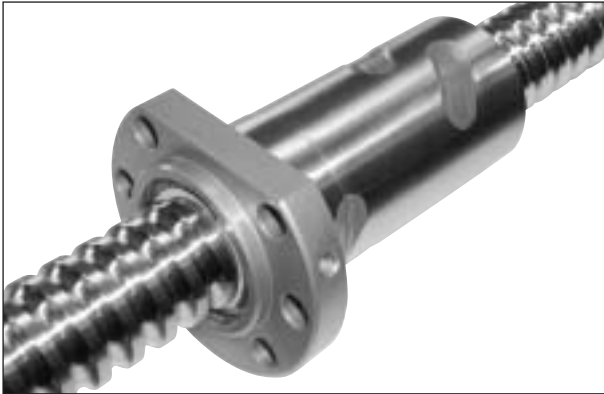

Drilling template 1

Model number	Screw shaft diameter d	Lead ℓ	Ball center-to-center diameter dp	Thread minor diameter d <sub>3</sub>	No. of loaded circuits/rows × turns	Basic load rating		Rigidity <sup>1)</sup> K [N/μm]
						C <sub>a</sub> [kN]	C <sub>0a</sub> [kN]	
* EPC1605-6RR	16	5	16.75	13.5	3×1	7.9	12.7	360
* EPC2005-6RR	20	5	20.75	17.5	3×1	9.2	16.9	439
* EPC2505-6RR	25	5	25.75	22.5	3×1	10.5	22.2	532
* EPC2510-4RR	25	10	26	21.9	2×1	9.8	17.6	369
* EPC3205-6RR	32	5	32.75	29.5	3×1	11.9	29.6	655
* EPC3205-8RR	32	5	32.75	29.5	4×1	15.3	39.5	862
* EPC3210-6RR	32	10	33.75	27.2	3×1	27.9	51.0	691
EPC4005-6RR	40	5	40.75	37.5	3×1	13.3	38.1	788
* EPC4010-6RR	40	10	41.75	35.2	3×1	32.4	67.8	842
* EPC4010-8RR	40	10	41.75	35.2	4×1	41.5	90.4	1108
EPC5005-6RR	50	5	50.75	47.5	3×1	14.6	48.7	945
EPC5005-12RR	50	5	50.75	47.5	6×1	26.6	97.3	1830
EPC5010-8RR	50	10	51.75	45.2	4×1	47.2	118.5	1342
EPC6310-8RR	63	10	64.7	58.2	4×1	53.9	157.8	1654

\* Also available with precision rolled screw shaft (Cp3 und Cp5).

<sup>1)</sup> The rigidity values in this table indicate spring constants obtained from the load and elastic displacement under a preload of 10% of the basic dynamic load rating C<sub>a</sub>, and an axial load F<sub>a</sub> that is three times that of the preload F<sub>a0</sub>. As these values do not take into account the rigidity of the parts involved in the nut installation, take 80% of the values given in this table as a general guideline.

If the preload F<sub>a0</sub> differs from 0.1 C<sub>a</sub>, the rigidity K<sub>N</sub> can be calculated using the following equation:

$$K_N = K \cdot \left( \frac{F_{a0}}{0.1 C_a} \right)^{\frac{1}{3}} \cdot 0.8$$

If the ballscrew is not preloaded, please consult **THK** for the rigidity value.

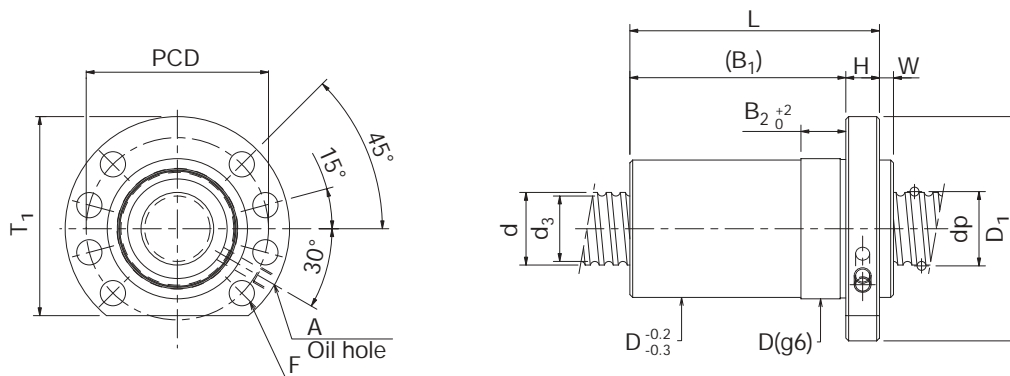

Drilling template 2

Unit: mm

Nut dimensions												Screw shaft inertial moment per mm [kg·cm <sup>2</sup> /mm]
Outer diameter D	Flange diameter D <sub>1</sub>	Overall length L	H	B <sub>1</sub>	B <sub>2</sub>	W	T <sub>1</sub>	PCD	F	Drilling template	Oil hole A	
28	48	60	10	50	10	5	44	38	5.5	1	M6×1	5.05×10 <sup>-4</sup>
36	58	61	10	51	10	5	51	47	6.6	1	M6×1	1.23×10 <sup>-3</sup>
40	62	61	10	51	10	5	55	51	6.6	1	M6×1	3.01×10 <sup>-3</sup>
40	62	80	10	70	16	5	55	51	6.6	1	M6×1	3.01×10 <sup>-3</sup>
50	80	62	12	50	10	5	71	65	9	1	M6×1	8.08×10 <sup>-3</sup>
50	80	73	12	61	10	5	71	65	9	1	M6×1	8.08×10 <sup>-3</sup>
50	80	107	12	95	10	5	71	65	9	1	M6×1	8.08×10 <sup>-3</sup>
63	93	65	14	51	10	5	81.5	78	9	2	M6×1	1.97×10 <sup>-2</sup>
63	93	109	14	95	16	5	81.5	78	9	2	M6×1	1.97×10 <sup>-2</sup>
63	93	133	14	119	16	5	81.5	78	9	2	M6×1	1.97×10 <sup>-2</sup>
75	110	70	16	54	10	5	97.5	93	11	2	M6×1	4.82×10 <sup>-2</sup>
75	110	105	16	89	10	5	97.5	93	11	2	M6×1	4.82×10 <sup>-2</sup>
75	110	135	16	119	16	5	97.5	93	11	2	M6×1	4.82×10 <sup>-2</sup>
90	125	137	18	119	16	5	110	108	11	2	M6×1	1.21×10 <sup>-1</sup>

### Model-Number Coding

**EPC 32 05 – 4 RR G0 + 1200L Cp5**

(1) (2) (3) (4) (5) (6) (7) (8)

(1) Nut

(2) Screw shaft outer diameter (mm)

(3) Lead (mm)

(4) Number of circuits (rows × turns)

(5) Seals (RR: labyrinth seals attached to both sides)

(6) Preload

(7) Screw shaft total length (mm)

(8) Accuracy (see page 10 - 15)

## Precision Ballscrew BIF

- Preload by pitch shifting
- Fixing dimensions according to THK
- Ground or precision rolled screw shafts available



Model number	Screw shaft diameter d	Lead ℓ	Ball center-to-center diameter dp	Thread minor diameter d <sub>3</sub>	No. of loaded circuits/rows × turns	Basic load rating		Rigidity <sup>1)</sup> K [N/μm]
						C <sub>a</sub> [kN]	C <sub>0a</sub> [kN]	
BIF1605-5	16	5	16.75	13.2	1 × 2.5	7.4	13.9	330
BIF2005-5	20	5	20.75	17.2	1 × 2.5	8.3	17.4	390
BIF2505-5	25	5	25.75	22.2	1 × 2.5	9.2	22.0	470
BIF2510A-5	25	10	26.3	21.4	1 × 2.5	15.8	33.0	500
BIF3205-5	32	5	32.75	29.2	1 × 2.5	10.2	28.1	570
BIF3210A-5	32	10	33.75	26.4	1 × 2.5	26.1	56.2	640
BIF4010-5	40	10	41.75	34.4	1 × 2.5	29.0	70.4	750
BIF4020-2,5	40	20	41.75	34.4	1 × 2.5	28.8	70.9	360
BIF5010-5	50	10	51.75	44.4	1 × 2.5	32.0	88.2	900
BIF5010-10	50	10	51.75	44.4	2 × 2.5	58.2	176.4	1750

<sup>1)</sup> The rigidity values in this table indicate spring constants obtained from the load and elastic displacement under a preload of 10% of the basic dynamic load rating C<sub>a</sub>, and an axial load F<sub>a0</sub> that is three times that of the preload F<sub>a0</sub>. As these values do not take into account the rigidity of the parts involved in the nut installation, take 80% of the values given in this table as a general guideline.

If the preload F<sub>a0</sub> differs from 0.1 C<sub>a</sub>, the rigidity K<sub>N</sub> can be calculated using the following equation:

$$K_N = K \cdot \left( \frac{F_{a0}}{0.1 C_a} \right)^{\frac{1}{3}} \cdot 0.8$$

If the ballscrew is not preloaded, please consult **THK** for the rigidity value.



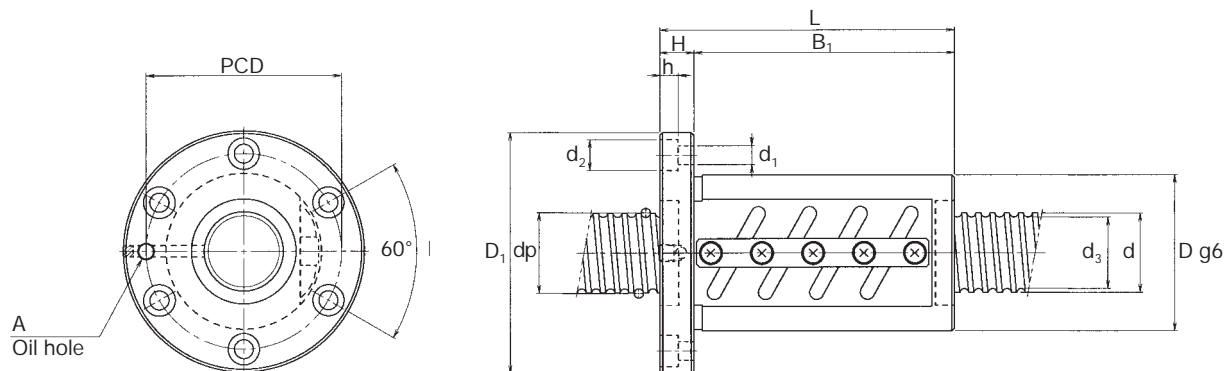

Einheit: mm

Outer diameter D	Flange diameter D <sub>1</sub>	Overall length L	Nut dimensions				Oil hole A	Screw shaft inertial moment per mm [kg · cm <sup>2</sup> / mm]
			H	B <sub>1</sub>	PCD	d <sub>1</sub> × d <sub>2</sub> × h		
40	60	56	10	46	50	4.5 × 8 × 4.5	M6×1	5.05 × 10 <sup>-4</sup>
44	67	56	11	45	55	5.5 × 9.5 × 5.5	M6×1	1.23 × 10 <sup>-3</sup>
50	73	55	11	44	61	5.5 × 9.5 × 5.5	M6×1	3.01 × 10 <sup>-3</sup>
58	85	100	18	82	71	6.6 × 11 × 6.5	M6×1	4.74 × 10 <sup>-3</sup>
58	85	56	12	44	71	6.6 × 11 × 6.5	M6×1	8.08 × 10 <sup>-3</sup>
74	108	100	15	85	90	9 × 14 × 8.5	M6×1	8.08 × 10 <sup>-3</sup>
82	124	103	18	85	102	11 × 17.5 × 11	M6×1	1.97 × 10 <sup>-2</sup>
84	126	105	18	87	104	11 × 17.5 × 11	M6×1	1.97 × 10 <sup>-2</sup>
93	135	103	18	85	113	11 × 17.5 × 11	PT 1/8	4.82 × 10 <sup>-2</sup>
93	135	163	18	145	113	11 × 17.5 × 11	PT 1/8	4.82 × 10 <sup>-2</sup>

### Model-Number Coding

**BIF 32 05 - 5 RR G0 + 1200L Cp5**

(1) (2) (3) (4) (5) (6) (7) (8)

- (1) Nut
- (2) Screw shaft outer diameter (mm)
- (3) Lead (mm)
- (4) Number of circuits (rows × turns)
- (5) Seals (RR: labyrinth seals attached to both sides)
- (6) Preload
- (7) Screw shaft total length (mm)
- (8) Accuracy (see page 10 - 15)

## Precision Ballscrew BNFN

- Preloaded double nut
- Fixing dimensions according to THK
- Ground or precision rolled screw shafts available



Model number	Screw shaft diameter d	Lead ℓ	Ball center-to-center diameter dp	Thread minor diameter d <sub>3</sub>	No. of loaded circuits/rows × turns	Basic load rating		Rigidity <sup>1)</sup> K [N/μm]
						C <sub>a</sub> [kN]	C <sub>0a</sub> [kN]	
BNFN1605-5	16	5	16.75	13.2	2 × 2.5	13.5	27.8	640
BNFN2005-5	20	5	20.75	17.2	2 × 2.5	15.1	35.0	760
BNFN2505-5	25	5	25.75	22.2	2 × 2.5	16.7	44.0	910
BNFN2510A-2,5	25	10	26.3	21.4	1 × 2.5	15.8	33.0	500
BNFN3205-5	32	5	32.75	29.2	2 × 2.5	18.5	56.4	1110
BNFN3210A-5	32	10	33.75	26.4	2 × 2.5	47.2	112.7	1230
BNFN4010-5	40	10	41.75	34.4	2 × 2.5	52.7	141.1	1470
BNFN4020-2,5	40	20	41.75	34.4	1 × 2.5	28.8	70.9	720
BNFN5005-3	50	5	50.75	47.2	2 × 1.5	14.2	53.0	970
BNFN5005-4,5	50	5	50.75	47.2	3 × 1.5	20.2	79.5	1420
BNFN5010-5	50	10	51.75	44.4	2 × 2.5	58.2	176.4	1750
BNFN6310-5	63	10	64.75	57.7	2 × 2.5	64.2	222.5	2100

<sup>1)</sup> The rigidity values in this table indicate spring constants obtained from the load and elastic displacement under a preload of 10% of the basic dynamic load rating C<sub>a</sub>, and an axial load F<sub>a0</sub> that is three times that of the preload F<sub>a0</sub>. As these values do not take into account the rigidity of the parts involved in the nut installation, take 80% of the values given in this table as a general guideline.

If the preload F<sub>a0</sub> differs from 0.1 C<sub>a</sub>, the rigidity K<sub>N</sub> can be calculated using the following equation:

$$K_N = K \cdot \left( \frac{F_{a0}}{0.1 C_a} \right)^{\frac{1}{3}} \cdot 0.8$$

If the ballscrew is not preloaded, please consult **THK** for the rigidity value.

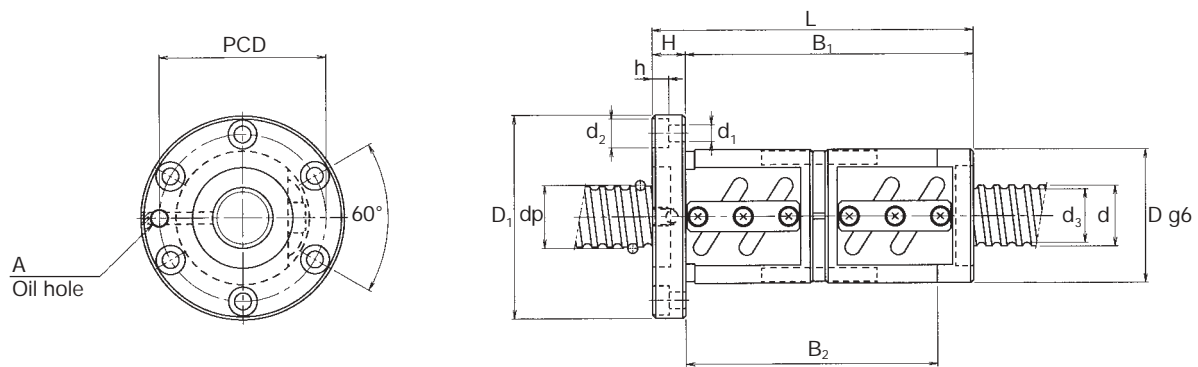

Einheit: mm

Outer diameter D	Flange diameter D <sub>1</sub>	Overall length L	Nut dimensions					Oil hole A	Screw shaft inertial moment per mm [kg · cm <sup>2</sup> / mm]
			H	B <sub>1</sub>	B <sub>2</sub>	PCD	d <sub>1</sub> × d <sub>2</sub> × h		
40	60	106	10	96	85	50	4.5 × 8 × 4.5	M6 × 1	5.05 × 10 <sup>-4</sup>
44	67	106	11	95	83	55	5.5 × 9.5 × 5.5	M6 × 1	1.23 × 10 <sup>-3</sup>
50	73	105	11	94	82	61	5.5 × 9.5 × 5.5	M6 × 1	3.01 × 10 <sup>-3</sup>
58	85	120	18	102	83	71	6.6 × 11 × 6.5	M6 × 1	3.01 × 10 <sup>-3</sup>
58	85	106	12	94	81	71	6.6 × 11 × 6.5	M6 × 1	8.08 × 10 <sup>-3</sup>
74	108	190	15	175	159	90	9 × 14 × 8.5	M6 × 1	8.08 × 10 <sup>-3</sup>
82	124	193	18	175	156	102	11 × 17.5 × 11	M6 × 1	1.97 × 10 <sup>-2</sup>
84	126	185	18	167	—	104	11 × 17.5 × 11	M6 × 1	1.97 × 10 <sup>-2</sup>
80	114	108	15	93	—	96	9 × 14 × 8.5	PT 1/8	4.82 × 10 <sup>-2</sup>
80	114	128	15	113	—	96	9 × 14 × 8.5	PT 1/8	4.82 × 10 <sup>-2</sup>
93	135	193	18	175	156	113	11 × 17.5 × 11	PT 1/8	4.82 × 10 <sup>-2</sup>
108	154	197	22	175	—	130	14 × 20 × 13	PT 1/8	1.21 × 10 <sup>-1</sup>

### Model-Number Coding

**BNFN 32 05 – 5 RR G0 + 1200L Cp5**

(1) (2) (3) (4) (5) (6) (7) (8)

- |                                       |  |
|---------------------------------------|--|
| (1) Nut                               | (5) Seals (RR: labyrinth seals attached to both sides) |
| (2) Screw shaft outer diameter (mm)   | (6) Preload  |
| (3) Lead (mm)                         | (7) Screw shaft total length (mm)                      |
| (4) Number of circuits (rows × turns) | (8) Accuracy (see page 10 - 15)                        |

## Precision Ballscrew BNF

- Nut with preload or non-preload
- Fixing dimensions according to THK
- Ground or precision rolled screw shafts available



Model number	Screw shaft diameter d	Lead ℓ	Ball center-to-center diameter dp	Thread minor diameter d <sub>3</sub>	No. of loaded circuits/rows × turns	Basic load rating		Rigidity <sup>1)</sup> K [N/μm]
						C <sub>a</sub> [kN]	C <sub>0a</sub> [kN]	
BNF1605-5	16	5	16.75	13.2	2 × 2.5	13.5	27.8	320
BNF2005-5	20	5	20.75	17.2	2 × 2.5	15.1	35.0	380
BNF2505-5	25	5	25.75	22.2	2 × 2.5	16.7	44.0	460
BNF2510A-2,5	25	10	26.3	21.4	1 × 2.5	15.8	33.0	250
BNF3205-5	32	5	32.75	29.2	2 × 2.5	18.5	56.4	560
BNF3210A-2,5	32	10	33.75	26.4	2 × 2.5	47.2	112.7	620
BNF4010-5	40	10	41.75	34.4	2 × 2.5	52.7	141.1	740
BNF4020-2,5	40	20	41.75	34.4	1 × 2.5	28.8	70.9	360
BNF5005-4,5	50	5	50.75	47.2	3 × 1.5	20.2	79.5	710
BNF5010-5	50	10	51.75	44.4	2 × 2.5	58.2	176.4	880
BNF5020-2,5	50	20	52.7	42.9	1 × 2.5	72.5	183.3	620
BNF6310-5	63	10	64.75	57.7	2 × 2.5	64.2	222.5	1050
BNF6320-2,5	63	20	65.7	55.9	1 × 2.5	81.0	231.3	740

<sup>1)</sup> The rigidity values in this table indicate spring constants obtained from the load and elastic displacement under an axial load of 30% of the basic dynamic load rating C<sub>a</sub>. As these values do not take into account the rigidity of the parts involved in the nut installation, take 80% of the values given in this table as a general guideline.

If the axial load F<sub>a</sub> differs from 0.3 C<sub>a</sub>, the rigidity K<sub>N</sub> can be calculated using the following equation:

$$K_N = K \cdot \left( \frac{F_{a0}}{0.1 C_a} \right)^{\frac{1}{3}} \cdot 0.8$$

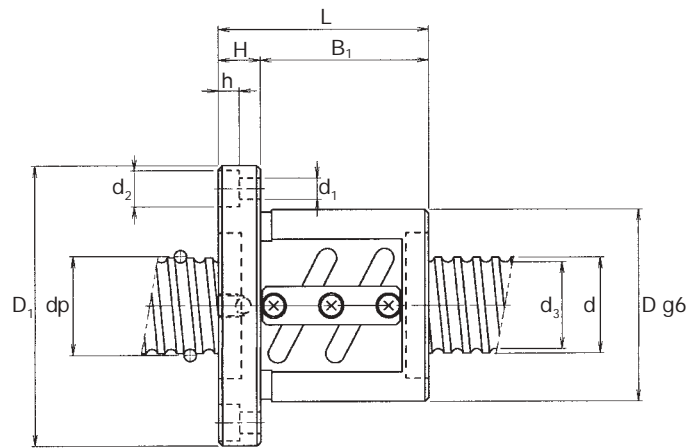
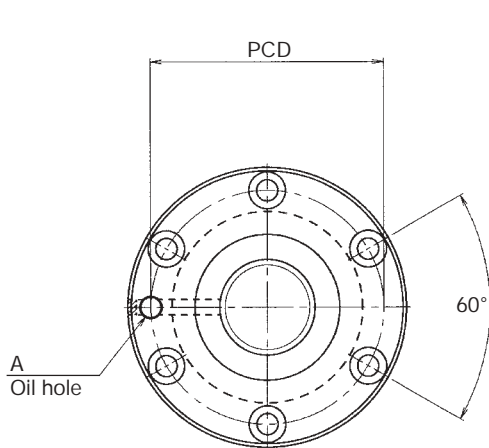

Einheit: mm

Outer diameter D	Flange diameter D <sub>1</sub>	Overall length L	Nut dimensions				Oil hole A	Screw shaft inertial moment per mm [kg · cm <sup>2</sup> / mm]
			H	B <sub>1</sub>	PCD	d <sub>1</sub> × d <sub>2</sub> × h		
40	60	56	10	46	50	4.5 × 8 × 4.5	M6×1	5.05 × 10 <sup>-4</sup>
44	67	56	11	45	55	5.5 × 9.5 × 5.5	M6×1	1.23 × 10 <sup>-3</sup>
50	73	55	11	44	61	5.5 × 9.5 × 5.5	M6×1	3.01 × 10 <sup>-3</sup>
58	85	70	18	52	71	6.6 × 11 × 6.5	M6×1	3.01 × 10 <sup>-3</sup>
58	85	56	12	44	71	6.6 × 11 × 6.5	M6×1	8.08 × 10 <sup>-3</sup>
74	108	100	15	85	90	9 × 14 × 8.5	M6×1	8.08 × 10 <sup>-3</sup>
82	124	103	18	85	102	11 × 17.5 × 11	M6×1	1.97 × 10 <sup>-2</sup>
84	126	105	18	87	104	11 × 17.5 × 11	M6×1	1.97 × 10 <sup>-2</sup>
80	114	68	15	53	96	9 × 14 × 8.5	PT 1/8	4.82 × 10 <sup>-2</sup>
93	135	103	18	85	113	11 × 17.5 × 11	PT 1/8	4.82 × 10 <sup>-2</sup>
105	152	141	28	113	128	14 × 20 × 13	PT 1/8	4.82 × 10 <sup>-2</sup>
108	154	107	22	85	130	14 × 20 × 13	PT 1/8	1.21 × 10 <sup>-1</sup>
122	180	187	28	159	150	18 × 26 × 17.5	PT 1/8	1.21 × 10 <sup>-1</sup>

### Model-Number Coding

**BNF 32 05 – 5 RR G0 + 1200L Cp5**

(1) (2) (3) (4) (5) (6) (7) (8)

- (1) Nut
- (2) Screw shaft outer diameter (mm)
- (3) Lead (mm)
- (4) Number of circuits (rows × turns)
- (5) Seals (RR: labyrinth seals attached to both sides)

- (6) Symbol for preload  
G0 = preloaded  
GT = without clearance
- (7) Screw shaft total length (mm)
- (8) Accuracy (see page 10 - 15)

## Transport Ballscrew BLK

- Large lead
- Single nut without clearance
- Fixing dimensions according to THK
- Precision rolled



Model number	Screw shaft diameter d	Lead ℓ	Ball center-to-center diameter dp	Thread minor diameter d <sub>3</sub>	No. of loaded circuits/rows × turns	Basic load rating		Rigidity <sup>1)</sup> K [N/μm]
						C <sub>a</sub> [kN]	C <sub>0a</sub> [kN]	
BLK1616-3,6	16	16	16.65	13.7	2 × 1.8	7.1	14.3	220
BLK1616-7,2			16.65	13.7	4 × 1.8	14.0	28.0	440
BLK2020-3,6	20	20	20.75	17.5	2 × 1.8	11.1	24.7	290
BLK2020-7,2			20.75	17.5	4 × 1.8	22.0	49.0	580
BLK2525-3,6	25	25	26.0	22.0	2 × 1.8	16.6	38.7	350
BLK2525-7,2			26.0	22.0	4 × 1.8	33.0	77.0	700
BLK3232-3,6	32	32	33.25	28.3	2 × 1.8	23.7	59.5	440
BLK3232-7,2			33.25	28.3	4 × 1.8	47.0	119.0	880
BLK4040-3,6	40	40	41.75	35.2	2 × 1.8	38.7	99.2	550
BLK4040-7,2			41.75	35.2	4 × 1.8	77.0	198.0	1100

<sup>1)</sup> The rigidity values in this table indicate spring constants obtained from the load and elastic displacement under an axial load of 30% of the basic dynamic load rating C<sub>a</sub>. As these values do not take into account the rigidity of the parts involved in the nut installation, take 80% of the values given in this table as a general guideline.

If the axial load F<sub>a</sub> differs from 0.3 C<sub>a</sub>, the rigidity K<sub>N</sub> can be calculated using the following equation:

$$K_N = K \cdot \left( \frac{F_{a0}}{0.1 C_a} \right)^{\frac{1}{3}} \cdot 0.8$$

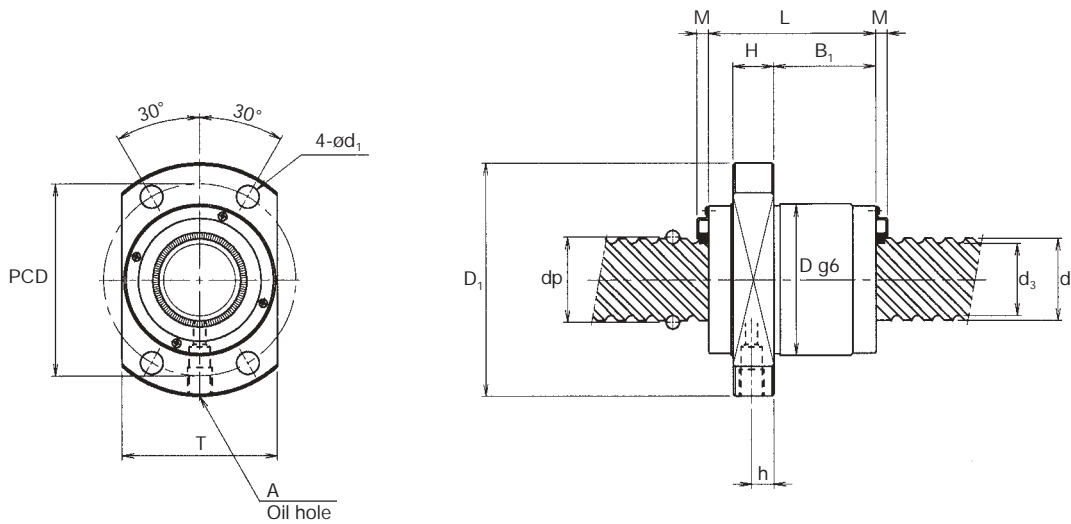

Unit: mm

Nut dimensions													Standard shaft length	Screw shaft inertial moment per mm [kg · cm <sup>2</sup> / mm]
Outer diameter D	Flange diameter D <sub>1</sub>	Overall length L	H	B <sub>1</sub>	PCD	d <sub>1</sub>	T	Oil hole		Seal	Axial-clearance	Standard shaft length		
								h	A	M				
32	53	38	10	21.5	42	4.5	38	5	M6	3.5	0.10	500, 1000	5.05 × 10 <sup>-4</sup>	
32	53	38	10	21.5	42	4.5	38	5	M6	3.5	0.10		5.05 × 10 <sup>-4</sup>	
39	62	45	10	27.5	50	5.5	46	5	M6	3.5	0.10	500, 1000	1.23 × 10 <sup>-3</sup>	
39	62	45	10	27.5	50	5.5	46	5	M6	3.5	0.10		1500	1.23 × 10 <sup>-3</sup>
47	74	55	12	35	60	6.6	56	6	M6	3.5	0.10	500, 1000	3.01 × 10 <sup>-3</sup>	
47	74	55	12	35	60	6.6	56	6	M6	3.5	0.10		1500	3.01 × 10 <sup>-3</sup>
58	92	70	15	45	74	9.0	68	7.5	M6	3.8	0.14	1000, 1500	8.08 × 10 <sup>-3</sup>	
58	92	70	15	45	74	9.0	68	7.5	M6	3.8	0.14		2000, 2500	8.08 × 10 <sup>-3</sup>
73	114	85	18	56.5	93	11.0	84	8.5	M6	5.4	0.17	1000, 1500	1.97 × 10 <sup>-2</sup>	
73	114	85	18	56.5	93	11.0	84	8.5	M6	5.4	0.17		2000, 3000	1.97 × 10 <sup>-2</sup>

### Model-Number Coding

**BLK 32 32 - 3,6 RR GT + 1200L Ct5**

(1) (2) (3) (4) (5) (6) (7) (8)

- (1) Nut
- (2) Screw shaft outer diameter (mm)
- (3) Lead (mm)
- (4) Number of circuits (rows × turns)
- (5) Seals (RR: labyrinth seals attached to both sides)
- (6) Symbol for axial clearance (only GT)
- (7) Screw shaft total length (mm)
- (8) Accuracy grade (only Ct5)

# Ballscrew Support Units Type BK/BF (Side Mounting Type)

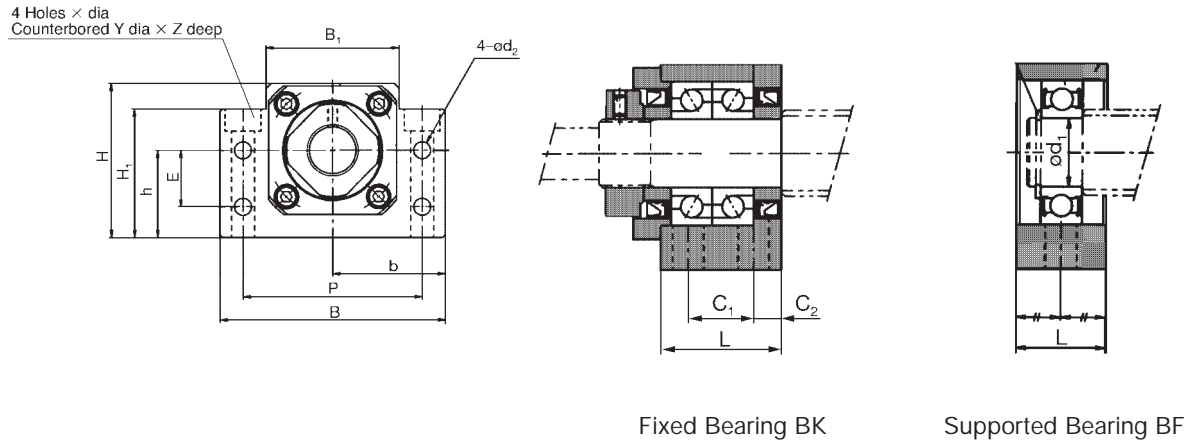

Unit: mm

	Body Sizes				Datums		Fixing Holes						Fixed Bearing Unit (BK)				Supported Bearing Unit (BF)					
	B	H	B <sub>1</sub>	H <sub>1</sub>	b	h	E	P	d <sub>2</sub>	X	Y	Z	L	Bearing	C <sub>1</sub>	C <sub>2</sub>	d <sub>1</sub>	Bearing	L	Circlip		
BK/BF10	60	39	34	32.5	30	22	15	46	5.5	6.6	11	5	BK10	25	7000DFGMP5	13	6	BF10	8	608ZZ	20	C8
BK/BF12	60	43	35	32.5	30	25	18	46	5.5	6.6	11	1.5	BK12	25	7001DFGMP5	13	6	BF12	10	6000ZZ	20	C10
BK/BF15	70	48	40	38	35	28	18	54	5.5	6.6	11	6.5	BK15	27	7002DFGMP5	15	6	BF15	15	6002ZZ	20	C15
BK/BF17	86	64	50	55	43	39	28	68	6.6	9	14	8.5	BK17	35	7203DFGMP5	19	8	BF17	17	6203ZZ	23	C17
BK/BF20	88	60	52	50	44	34	22	70	6.6	9	14	8.5	BK20	35	7004DFGMP5	19	8	BF20	20	6004ZZ	26	C20
BK/BF25	106	80	64	70	53	48	33	85	9	11	17.5	11	BK25	42	7205DFGMP5	22	10	BF25	25	6205ZZ	30	C25
BK/BF30	128	89	76	78	64	51	33	102	11	14	20	13	BK30	45	7206DFGMP5	23	11	BF30	30	6206ZZ	32	C30
BK/BF35	140	96	88	79	70	52	35	114	11	14	20	13	BK35	50	7207DFGMP5	26	12	BF35	35	6207ZZ	32	C35
BK/BF40	160	110	100	90	80	60	37	130	14	18	26	17.5	BK40	61	7208DFGMP5	33	14	BF40	40	6208ZZ	37	C40

Note: For BK units specify J1, J2 or J3 machining. For BF units specify K machining.



# End Machining for BK/BF

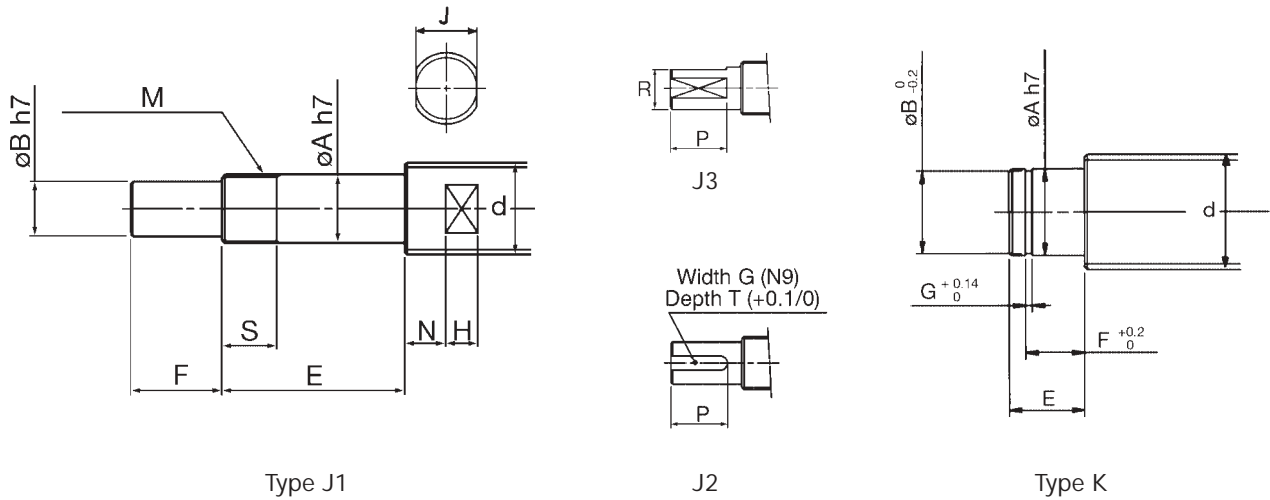

Type J1

J2

Type K

Unit: mm

d	Fixed	Type J Dimensions									Keyway Type J2			Flats Type J3		Supported	Typ K Dimensions				
		A	B	E	F <sup>1)</sup>	M	S	J	N	H	G	T	P	R	P		BF	A	E	B	F
14	BK10	10	8	39	15	M10 × 1	16	10	5	7	2	1.2	11	7.5	11	BF10	8	10	7.6	7.9	0.9
15	BK10	10	8	39	15	M10 × 1	16	10	5	7	2	1.2	11	7.5	11	BF10	8	10	7.6	7.9	0.9
16	BK12	12	10	39	15	M12 × 1	14	13	6	8	3	1.8	12	9.5	12	BF12	10	11	9.6	9.15	1.15
18	BK12	12	10	39	15	M12 × 1	14	13	6	8	3	1.8	12	9.5	12	BF12	10	11	9.6	9.15	1.15
20	BK15	15	12	40	20	M15 × 1	12	16	6	9	4	2.5	16	11.3	16	BF15	15	13	14.3	10.15	1.15
25	BK17	17	15	53	23	M17 × 1	17	18	7	10	5	3.0	21	14.3	21	BF17	17	16	16.2	13.15	1.15
28	BK20	20	17	53	25	M20 × 1	15	21	8	11	5	3.0	21	16.0	21	BF20	20	16	19.0	13.35	1.35
30	BK20	20	17	53	25	M20 × 1	15	24	8	12	5	3.0	21	16.0	21	BF20	20	16	19.0	13.35	1.35
32	BK20	20	17	53	25	M20 × 1	15	27	9	13	5	3.0	21	16.0	21	BF20	20	16	19.0	13.35	1.35
36	BK25	25	20	65	30	M25 × 1.5	18	27	10	13	6	3.5	25	19.0	25	BF25	25	20	23.9	16.35	1.35
40	BK30	30	25	72	38	M30 × 1.5	25	32	10	15	8	4.0	32	23.5	32	BF30	30	21	28.6	17.75	1.75
45	BK35	35	30	83	45	M35 × 1.5	28	36	12	15	8	4.0	40	28.5	40	BF35	35	22	33.0	18.75	1.75
50	BK40	40	35	98	50	M40 × 1.5	35	41	14	19	10	5.0	45	33.0	45	BF40	40	23	38.0	19.95	1.95
55	BK40	40	35	98	50	M40 × 1.5	35	46	14	20	10	5.0	45	33.0	45	BF40	40	23	38.0	19.95	1.95

<sup>1)</sup> Drive end length F may be customer specified to suit drive coupling. If not specified the length in the table will be used.

# Ballscrew Support Units Type FK/FF (Flange Mounting Type)

4 Holes × dia  
Counterbored Y dia × Z deep

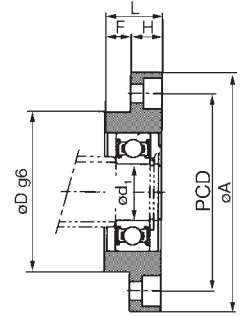
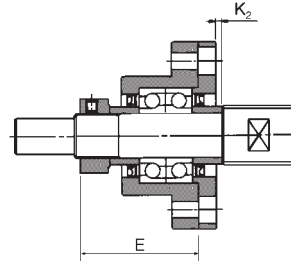
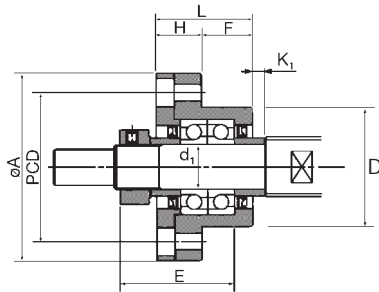
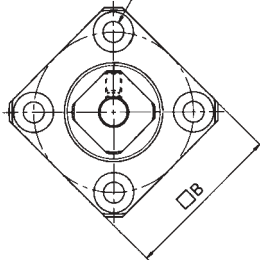

Fixed Bearing FK

Supported Bearing FF

Unit: mm

	Body Sizes & Fixing Holes							Fixed Bearing Unit (FK)							Supported Bearing Unit (FF)								
	Dg6	A	PCD	B	X	Y	Z		d <sub>1</sub>	L	H	F	E	K <sub>1</sub>	K <sub>2</sub>	Bearing		d <sub>1</sub>	L	H	F	Bearing	
FK4	18	32	24	25	3.4	6.5	4	FK4	4	15	6	9	17.5	1.5	0.5	AC4-12P5							
FK5	20	34	26	26	3.4	6.5	4	FK5	5	16.5	6	10.5	18.5	2.0	0.5	AC5-14P5							
FK/FF6	22	36	28	28	3.4	6.5	4	FK6	6	20	7	13	22	3.5	0.5	AC6-16P5	FF6	6	10	6	4	606ZZ	
FK8/FF10	28	43	35	35	3.4	6.5	4	FK8	8	23	9	14	26	3.5	0.5	AC8-18P5	FF10	8	12	7	5	608ZZ	
FK10/FF12	34	52	42	42	4.5	8	4	FK10	10	27	10	17	29.5	0.5	-0.5	7000DFGMP5	FF12	10	15	7	8	6000ZZ	
FK12	36	54	44	44	4.5	8	4	FK12	12	27	10	17	29.5	0.5	-0.5	7001DFGMP5							
FK/FF15	40	63	50	52	5.5	9.5	6	FK15	15	32	15	17	36	4.0	2.0	7002DFGMP5	FF15	15	17	9	8	6002ZZ	
FK/FF20	57	85	70	68	6.6	11	10	FK20	20	52	22	30	50	1.0	-3.0	7204DFGMP5	FF20	20	20	11	9	6204ZZ	
FK/FF25	63	98	80	79	9	15	13	FK25	25	57	27	30	60	5.0	-2.0	7205DFGMP5	FF25	25	24	14	10	6205ZZ	
FK/FF30	75	117	95	93	11	17.5	15	FK30	30	62	30	32	61	3.0	-9.0	7206DFGMP5	FF30	30	27	18	9	6206ZZ	

Note: For FK units specify H1, H2 or H3 machining. For FF units specify K machining.

# End Machining for FK/FF

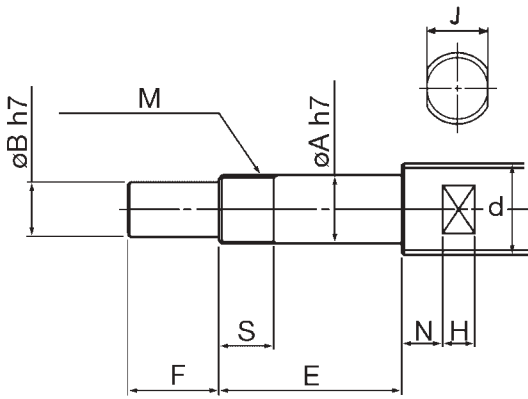

Type H1

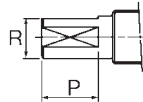

H3

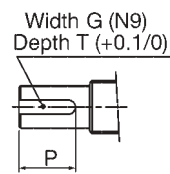

H2

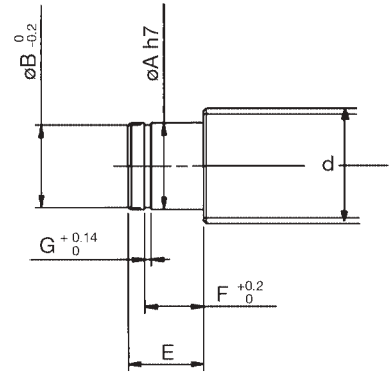

Type K

Unit: mm

d	Fixed	Type H Dimensions										Keyway Type H2			Flats Type H3		Supported	Type K Dimensions				
		A	B	E	F <sup>1)</sup>	M	S	J	N	H	G	T	P	R	P	FF		A	E	B	F	G
6	FK4	4	3	23	5	M4 × 0.5	7	4	4	4				2.7	4							
8	FK5	5	4	25	6	M5 × 0.5	7	5	4	4				3.7	5							
8	FK6	6	4	30	8	M6 × 0.75	8	5	4	4				3.7	6							
12	FK8	8	6	35	9	M8 × 1	10	8	5	5				5.6	7							
14	FK10	10	8	36	15	M10 × 1	11	10	5	7	2	1.2	11	7.5	11	FF10	8	10	7.6	7.9	0.9	
15	FK10	10	8	36	15	M10 × 1	11	10	5	7	2	1.2	11	7.5	11	FF10	8	10	7.6	7.9	0.9	
16	FK12	12	10	36	15	M12 × 1	11	13	6	8	3	1.8	12	9.5	12	FF12	10	11	9.6	9.15	1.15	
18	FK12	12	10	36	15	M12 × 1	11	13	6	8	3	1.8	12	9.5	12	FF12	10	11	9.6	9.15	1.15	
20	FK15	15	12	49	20	M15 × 1	13	16	6	9	4	2.5	16	11.3	16	FF15	15	13	14.3	10.15	1.15	
25	FK15	15	12	49	20	M15 × 1	13	18	7	10	4	2.5	16	11.3	16	FF15	15	13	14.3	10.15	1.15	
28	FK20	20	17	64	25	M20 × 1	17	21	8	11	5	3.0	21	16	21	FF20	20	19	19.0	15.35	1.35	
30	FK20	20	17	64	25	M20 × 1	17	24	8	12	5	3.0	21	16	21	FF20	20	19	19.0	15.35	1.35	
32	FK20	20	17	64	25	M20 × 1	17	27	9	13	5	3.0	21	16	21	FF20	20	19	19.0	15.35	1.35	
36	FK25	25	20	76	30	M25 × 1.5	20	27	10	13	6	3.5	25	19	25	FF25	25	20	23.9	16.35	1.35	
40	FK30	30	25	72	38	M30 × 1.5	25	32	10	15	8	4.0	32	23.5	32	FF30	30	21	28.6	17.75	1.75	

<sup>1)</sup> Drive end length F may be customer specified to suit drive coupling. If not specified the length in the table will be used.

# THK Standard Ballscrews

Specifications are subject to change without notice

09/2003 Printed in Belgium

## Sales Offices

### U.K.

**THK U.K.**  
26 Alston Drive  
Bradwell Abbey  
Milton Keynes,  
MK13 9HA  
Tel. (0 19 08) 22 21 59  
Fax (0 19 08) 22 21 61  
info-mks@thk.co.uk

### Austria

**THK Austria**  
Edelmüllerstraße 2  
4061 Pasching  
Tel. (0 72 29) 51 40-0  
Fax (0 72 29) 51 40-0 79  
info-lnz@thk.at

### France

**THK France**  
Parc des Bruyères  
58, Chemin de la Bruyère  
69570 Dardilly  
Tel. (04) 37 49 14 00  
Fax (04) 37 49 14 01  
info-lys@thk.fr

### Italy

**THK Italy**  
Via Buonarroti, 182  
20052 Monza (MI)  
Tel. (0 39) 2 84 20 79  
Fax (0 39) 2 84 25 27  
info-mil@thk-italia.it

**THK Bologna**  
Via della Salute 16/2  
40132 Bologna  
Tel. (0 51) 6 41 22 11  
Fax (0 51) 6 41 22 30  
info-blq@thk-italia.it

### Germany

**THK GmbH**  
**European Headquarters**  
**Düsseldorf Office**  
Hubert-Wollenberg-Str. 15  
40878 Ratingen  
Tel. (0 21 02) 74 25-0  
Fax (0 21 02) 74 25-29 9  
www.thk.de  
info-dus@thk.de

**Stuttgart Office**  
Heinrich-Lanz-Str. 3  
70825 Korntal-Münchingen  
Tel. (0 71 50) 91 99-0  
Fax (0 71 50) 91 99-8 88  
info-str@thk.de

**Munich Office**  
Max-Planck-Straße 13  
85716 Unterschleißheim  
Tel. (0 89) 37 06 16-0  
Fax (0 89) 37 06 16-26  
info-muc@thk.de

### Spain

**THK Spain**  
C/Andorra 19 A  
08830 San Boi de Llobregat  
Tel. (93) 652 5740  
Fax (93) 652 5746  
info-bcn@thk.es

### Sweden

**THK Sweden**  
Saldovägen 2  
17562 Järfälla  
Tel. (8) 44 57 63 0  
Fax (8) 44 57 63 9  
info-sto@thk.se

### Switzerland

**Bachofen-AG**  
Ackerstraße 42  
8610 Uster  
Tel. (01) 9 44 11 11  
Fax (01) 9 44 12 33  
Internet: www.bachofen.ch  
e-mail: info@bachofen.ch

### USA

**THK Atlanta**  
6135-E Northbelt Drive  
Norcross, GA. 30071  
Tel. (7 70) 8 40-79 90  
Fax (7 70) 8 40-78 97  
atlanta@thk.com

**THK Chicago**  
200 East Commerce Drive  
Schaumburg, IL. 60173  
Tel. (8 47) 3 10-11 11  
Fax (8 47) 3 10-12 71  
www.thk.com  
chicago@thk.com

**THK Detroit**  
4190 Telegraph Rd. Suite 2500  
Bloomfield Hill, MI. 48302  
Tel. (2 48) 5 94-75 52  
Fax (2 48) 5 94-75 58

**THK Los Angeles**  
6000 Phyllis Drive  
Cypress, CA. 90630  
Tel. (7 14) 8 91-67 52  
Fax (7 14) 8 94-93 15  
losangeles@thk.com

**THK New Jersey**  
300 F, RT.17, South  
Mahwah, NJ. 07430  
Tel. (2 01) 5 29-19 50  
Fax (2 01) 5 29-19 62  
newjersey@thk.com

**THK San Francisco**  
290 Lindbergh Avenue  
Livermore, CA. 94550  
Tel. (9 25) 4 55-89 48  
Fax (9 25) 4 55-89 65  
sanfrancisco@thk.com

### Canada

**THK Canada**  
130 Matheson Blvd. E., U. 1  
Mississauga, Ontario  
Canada L4Z 1Y6  
Tel. (9 05) 7 12-29 22  
Fax (9 05) 7 12-29 25  
canada@thk.com

### Brasil

**THK Brasil Ltda.**  
Indústria e Comércio Ltda.  
Av. Corifeu de Azevedo  
Marques, 4077  
Butantã - São Paulo - SP  
05330-002  
Tel. (55-11) 37 67-01 00  
Fax (55-11) 37 67-01 00  
thk@thk.com.br  
www.thk.com.br

### China

**THK Beijing**  
Kunlun Hotel Room No.526  
2 Xin Yuan Lu  
Chaoyang District Beijing  
Tel. (10) 65 90-35 57  
Fax (10) 65 90-35 57

### Hongkong

**THK Shouzan Co., Ltd.**  
4/Fl., Hanyee Bldg., Flat C  
19-21 Hankow Road  
Tsimshatsui, Kowloon  
Tel. (8 52) 37 61 09 1  
Fax (8 52) 37 60 74 9

### India

**THK India**  
1050, 11th Main r.p.c.  
Layout Bangalore 560040  
Tel. (0 80) 3 30-15 24  
Fax (0 80) 3 30-15 24  
thk@satyam.net.in

### Malaysia

**THK Malaysia**  
19-12-1, Mont Kiara Palma  
Jalan Mont Kiara, Off  
Jalan Bukit Kiara  
50480 Kuala Lumpur  
Tel. (03) 2 54-70 07  
Fax (03) 2 54-70 07

### Taiwan

**THK Taiwan**  
C611 SHIH, 6F, No. 7  
Wu-Chuan 1 Rd.  
Wu-Ku Kung Yeh Chu  
Hsin Chuang City  
Taipei Hsien  
Tel. (02) 22 96-49 90  
Fax (02) 22 97-81 49

## Plants

### Europe

**THK Manufacturing of Europe, S.A.S.**  
Parc d'Activités la  
Passerelle  
68190 Ensishheim  
Tel. (03) 89 83 44 00  
Fax (03) 89 83 44 09

**PGM Ballscrews Ltd.**  
Bodmin Road, Wyken  
Coventry CV2 5DZ  
Tel. (012 03) 84 19 00  
Fax (012 03) 61 10 32

**PGM Ireland Ltd.**  
18 Cookstown  
Industrial Estate  
Tallaght, Dublin 24  
Tel. (01) 4 51 39 22  
Fax (01) 4 51 34 69

### USA

**THK Manufacturing of America, Inc.**  
471 North High Street  
Hebron, OH. 43025  
Tel. (7 40) 9 28-14 15  
Fax (7 40) 9 28-14 18

### Japan

**Head Office:**  
3-11-6 Nishi-Gotanda  
Shinagawa-Ku  
Tokyo 141  
Tel. (03) 54 34-03 41  
Fax (03) 54 34-03 45  
www.thk.co.jp  
thk001@thk.co.jp

**Plants in:**  
Kofu, Yamaguchi,  
Yamagata, Mie, Tokyo,  
Nagoya, Osaka, Gifu,  
etc.