

| SNR, your guide to linear modules

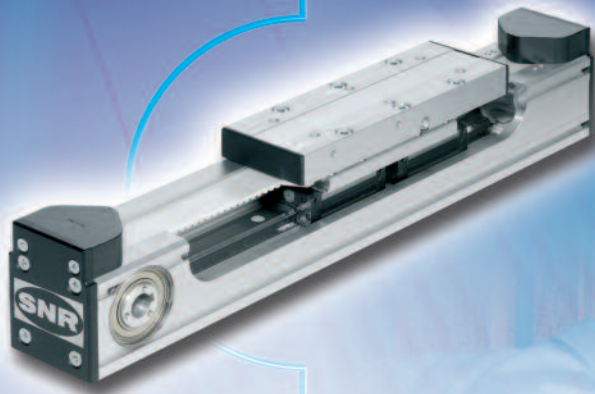

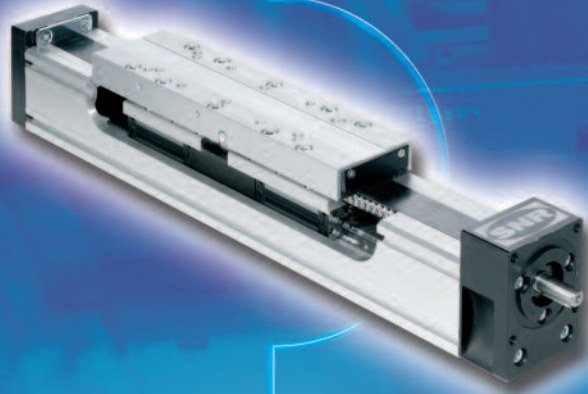

SNR – A bearing manufacturer known across the world



For almost a century SNR has been focusing on the development, design and manufacture of bearings.

Today SNR has a distribution network in more than 200 countries on 5 continents. We offer you our expertise as Europe's third largest bearing manufacturer with worldwide production facilities.

SNR has been ISO 9001 certified since 1990. AQF and QS 9000 certification followed soon after. We are rounding off our quality policy with ISO 14001 certification and ISO 9001-2000 for design and sales.

SNR linear modules are developed, fabricated and tested under near-production conditions in our plant in Bielefeld. With a well-organised network of sales engineers and sales agents worldwide we can offer you dedicated and competent technical support at any time.

SNR linear axes are universally applicable modules that accommodate the steadily growing requirements for the automation of installation and manufacturing processes.

They are suitable for the most diverse applications in various industries: room automation, machine tools, electrical engineering/electronic hardware, automobile

industry, printing industry, special-purpose machines, clean-room applications in the semiconductor industry, food industry.

The variants are built according to a modular design and depending on the problem, offer not only flexible drive and guiding concepts but also allow adequate freedom for customized solutions.

This means lower building costs and expenses for the user.

SNR linear axes can be quickly combined with each other and integrated into existing systems. They bring additional advantages through their reliability and durability.

SNR Engineering provides one-stop support for the design of individual linear axes and the development of system solutions. Through the optimal interaction of mechanics and electronics we offer short design times with optimized system configurations.

1. Product Description 4-21

2. Linear Axes - AXC Series

AXC40Z	22
AXC40S	24
AXC60Z	26
AXC60A	28
AXC60S	30
AXC80Z	32
AXC80A	34
AXC80S	36
AXC120Z	38
AXC120A	40
AXC120S	42

3. Parallel Modules - AXDL Series

AXDL110Z	44
AXDL110S	46
AXDL160Z	48
AXDL160S	50
AXDL240Z	52
AXDL240S	54



4. Linear Tables - AXLT Series

AXLT155	56
AXLT225	58
AXLT325	60
AXLT455	62

5. Linear Axes - AXS Series

AXS120TM	64
AXS160M160	66
AXS200M200	68
AXS200M250	70
AXS230M320	72
AXS280M400	74
AXS280Z	76
AXS280M200	78
AXS460M250	80

6. Drive adaptation AXC / AXDL / AXLT 82 - 91

7. Switch 92 - 99

8. Couplings and fasteners	100 - 110
<hr/>	
9. Groove cover for AXC	111
<hr/>	
10. Sets and kits	112-119
<hr/>	
11. General information about lubrication	120
<hr/>	
12. Special solutions	122
<hr/>	
13. Type designation code for SNR Linear Axes ...	127
<hr/>	
14. Enquiry guide	128
<hr/>	
15. Additional documentation	130



Project Overview

AXC / AXDL / AXLT

	Profile diameter [mm]	Drive element	Pitch [mm] or (Belt) pulley feed [mm/rev.]	Max. dynamic working load [N]	Speed [m/s]	Ball rail system	Roller guide
AXC40-Z	40 x 40	Synchronous belt drives	75	210	10		
AXC60-Z	60 x 60		150	560	10		
AXC80-Z	80 x 80		200	870	10		
AXC120-Z	120 x 120		320	2500	10		
AXDL110-Z	110 x 50		175	980	10		
AXDL160-Z	160 x 66		224	1830	10		
AXDL240-Z	240 x 100		272	5000	10		
AXC60-A	60 x 60		150	560	10		
AXC80-A	80 x 80		200	870	10		
AXC120-A	120 x 120		320	2500	10		
AXC40-S	40 x 40	Screw-type drive	3/ 5/ 10	1000	1		
AXC60-S	60 x 60		4/ 5/ 8/ 10/ 16	3600	1,6		
AXC80-S	80 x 80		4/ 5/ 8/ 20/ 50	5200	2		
AXC120-S	120 x 120		5/ 6/ 10/ 12/ 20/ 32	9500	2		
AXDL110-S	110 x 50		4/ 5/ 8/ 10/ 16	3600	1,6		
AXDL160-S	160 x 66		4/ 5/ 8/ 10/ 20/ 50	5200	2		
AXDL240-S	240 x 100		5/ 6/ 10/ 12/ 20/ 32	9500	2		
AXLT155	155 x 33		4/ 5/ 8/ 20	5200	2		
AXLT225	225 x 40		5/ 10/ 25	4700	2		
AXLT325	325 x 50		5/ 6/ 10/ 12/ 20/ 32	9500	2		
AXLT455	455 x 70	5/ 7/ 10/ 20/ 40	16300	2			

AXC profile sections

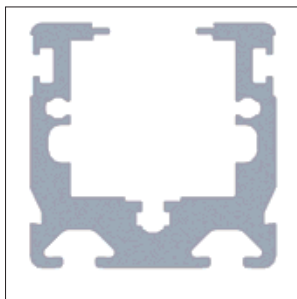

AXC40

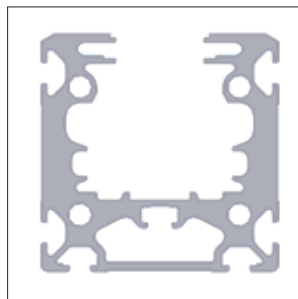

AXC60

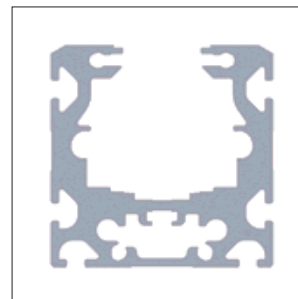

AXC80

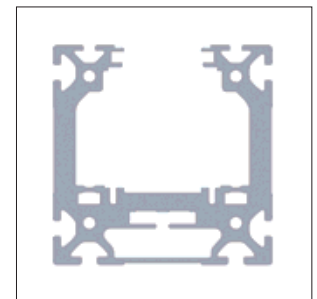

AXC120

no guidance	Max, total length [m]	Max, loads and torque loads (dynamic)					
		Fy[N]	Fz [N]	-Fz [N]	Mx [Nm]	My [Nm]	Mz [Nm]
	6	310	170	170	2,4	3,9	7,0
	8	2750	2750	2750	19	95	95
	8	5400	5400	5400	60	310	310
	8	10500	10500	10500	145	1750	1750
	6,1	2200	2200	7700	75	100	100
	6,1	8700	8700	8700	430	430	430
	6,35	12300	12300	12300	950	1050	1050
	8	2750	2750	2750	19	95	95
	8	4300	4300	4300	43	205	205
	10	8700	8700	8700	120	790	790
	2,5	660	660	660	4,5	18	18
	3,5	3400	3400	3400	24	200	200
	5,5	5400	5400	5400	54	420	420
	4,5	11000	11000	11000	150	950	950
	3,5	2800	2800	2800	95	130	130
	3,5	10900	10900	10900	540	700	700
	4,5	15500	15500	15500	1200	1300	1300
	3,5	6900	6900	6900	340	420	420
	3,5	10900	10900	10900	810	930	930
	3,2	22000	22000	22000	2250	2700	2700
	3,2	30000	30000	30000	3950	3700	3700

AXDM profile sections

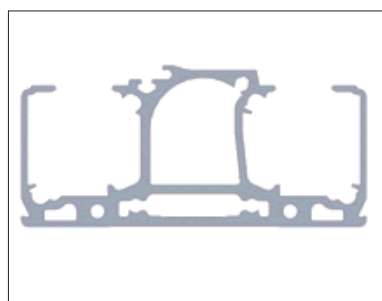

AXDL110

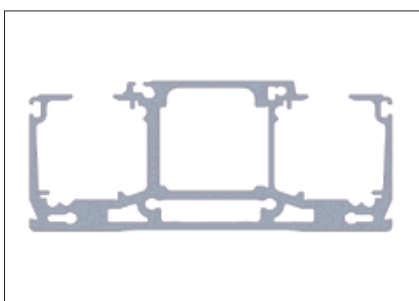

AXDL160

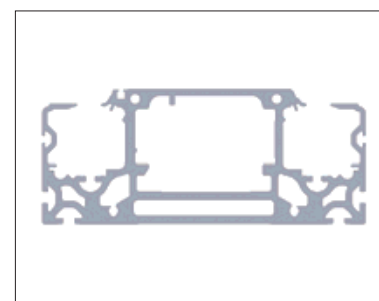

AXDL240



I Project Overview AXS

	AXS120T	AXS200M	AXS230M	AXS280Z	AXS280M	AXS460M	
Profile diameter [mm]	120x120	200x100	230x160	280x170	280x170	400x300	
Drive element	synchronous belt rack and pinion	rack and pinion	rack and pinion	rack and pinion	rack and pinion	rack and pinion	
Input constant [mm/rev.]	500 280	250 200	320	480	400 200	250	
Max. dynamic working load [N]	2500	6130	10750	4000	3190	5860	
Speed [m/s]	10	3,4	2,5	6	3,3	6	
Ball rail guide	•	•	•	•	•	•	
Max. total length [m]	3	6	10	10*	10*	10*	
Max. loads and torque loads Lastmomente (dynamisch)	Fy [N]	12200	17400	17400	24000	28000	28000
	Fz [N]	12200	17400	17400	24000	28000	28000
	-Fz [N]	12200	17400	17400	24000	28000	28000
	Mx [Nm]	470	1200	1200	2600	3000	4500
	My [Nm]	1750	2200	1850	2950	4300	5800
	Mz [Nm]	1750	2200	1850	2950	4300	5800

* Greater lengths with jointed aluminum sections available upon request.

I Dynamic load ratings of the linear guidance systems

Axis	Guidance	Cy [kN]	Cz [kN]	Mx [kNm]	My [kNm]	Mz [kNm]
AXC40S	B	6,40	5,38	0,02	0,15	0,18
AXC40Z	L	2,68	1,65	0,02	0,04	0,06
AXC60S	B	11,46	11,46	0,04	0,57	0,57
	C	27,86	27,86	0,10	1,76	1,76
	L	6,83	4,43	0,08	0,22	0,33
AXC60Z	B	27,86	27,86	0,10	1,03	1,03
	L	6,83	4,43	0,08	0,22	0,33
AXC80S	B	45,92	45,92	0,21	3,88	3,88
	L	6,54	9,11	0,2	0,46	0,65
	F	-	-	-	-	-
AXC80Z	B	45,92	45,92	0,21	2,32	2,32
	C	45,92	45,92	0,21	2,76	2,76
	L	24,17	16,11	0,44	0,81	1,21
AXC120S	C	95,08	95,08	0,62	9,22	9,22
	L	24,17	16,11	0,54	1,82	2,73
AXC120Z	B	95,08	95,08	0,62	8,75	9,74
	C	105,86	105,86	0,69	21,22	21,22
	L	36,25	24,17	0,81	1,82	2,73
	M	48,33	32,22	1,07	4,29	6,44
AXDL110S	B	22,92	22,92	0,80	1,12	
AXDL110Z	B	22,92	22,92	0,80	1,12	
	L	1,75	1,77	0,07	0,09	
AXDL160S	B	91,84	91,84	4,82	6,43	
AXDL160Z	B	91,84	91,84	4,82	4,78	
	L	10,13	10,13	0,51	0,70	
AXDL240S	B	127,72	127,72	10,73	11,88	
AXDL240Z	B	127,72	127,72	10,73	11,88	
	L	24,77	24,77	2,11	1,96	
AXLT155	B	55,72	55,72	2,93	2,38	
AXLT155	C	55,72	55,72	2,93	3,43	
AXLT225	B	91,84	91,84	7,35	6,47	
AXLT225	C	91,84	91,84	7,35	8,59	
AXLT325	B	190,16	190,16	21,87	19,40	
AXLT325	C	190,16	190,16	21,87	26,62	
AXLT455	B	261,48	261,48	39,22	36,61	
AXS120T-E1	B	127,72	127,72	5,11	21,07	
AXS120T-E2	B	71,00	71,00	3,26	6,57	
AXS200-M200	B	190,16	190,16	14,26	13,12	
AXS200-M250	B	190,16	190,16	14,26	23,20	
AXS230-M	B	190,16	190,16	14,26	23,01	
AXS280-M	B	287,68	287,68	34,81	52,36	
AXS280-Z	B	261,48	261,48	31,64	36,35	
AXS460-M	B	287,68	287,68	54,66	74,94	



I Compact modules

The compact linear axes of the AXC series are universally applicable as single-axis or in combination with other axes from this series or linear axes from our system range (AXS) in complex multiple-axis systems.

• Integrated coupling

Friction-locked torque transfer is achieved using a coupling screwed down with a pulley. This torque transfer also ensures a permanent backlash-free and wear-free connection compared with conventional feather key couplings, even in the highest dynamic range. The drive and deflection pulley are integrated into the aluminium section, thus resulting in an optimum relationship between travel distance and total length of the linear axis.

• Scraper brushes

The scraper brushes reliably remove major contamination from the cover strip and aluminum section.

• Cover strip

A cover strip of tried and tested design protects the interior guidance and drive system from contamination. The guide rollers of the cover strip ensure low-friction operation. The special geometry also ensures an optimal seat for the cover strip even in overhead installations.

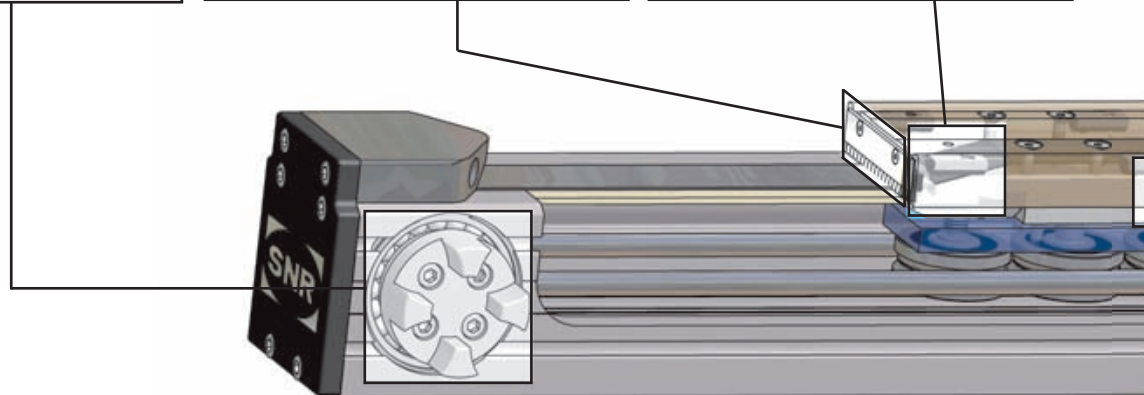
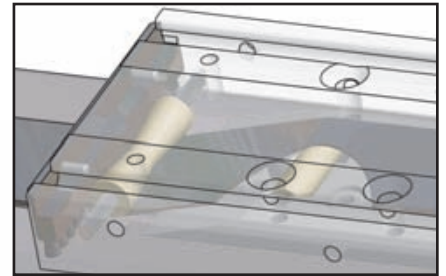
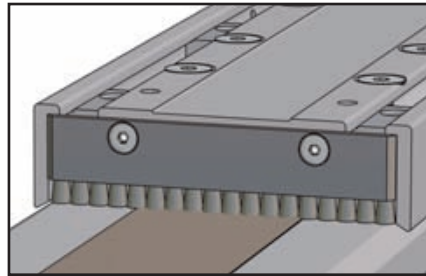
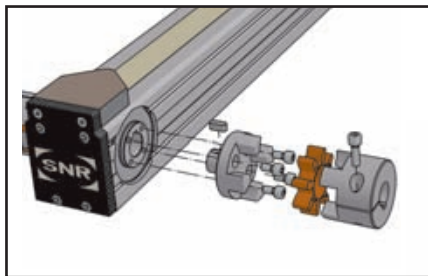

- **Variable guidance system**

The variable use of roller guides or Ball rail guides allows optimal adaptation to the application.

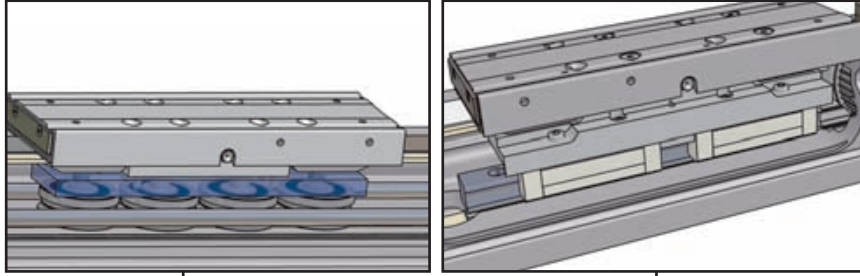

- **Convenient relubrication**

All AXC-type linear axes with ball screw or ball rail system are fitted with lubricating nipples on both sides to allow the best possible accessibility. The screw-type drive and linear guidance are individually regreasable to ensure optimal lubricant supply for both.

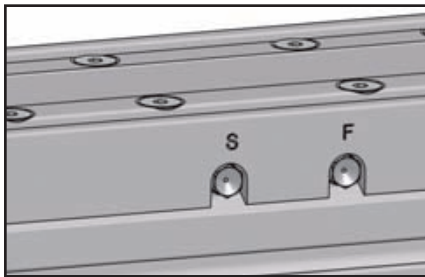

- **Synchronous belt tension**

Radially adjustable mounting of the deflection pulley ensures 100% adjustability and reproducibility for the prescribed belt tension. This technology allows retensioning of the belt without having to remove the load in case of servicing.

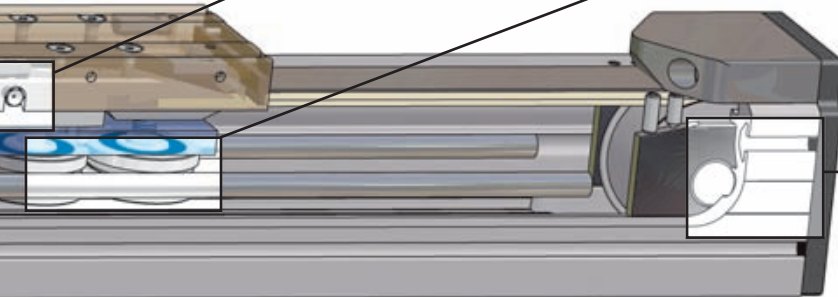
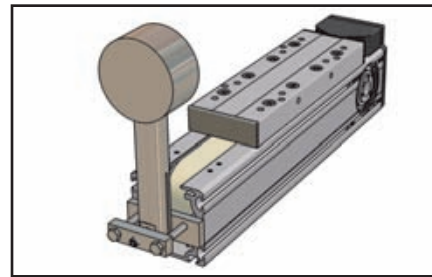



I Parallel modules

- **Profiles with high rigidity**

The closed profiles offer high rigidity especially in designs with synchronous belt drive.

- **Relubrication**

Guidance system and ball screw are individually regreasable. Lubricating points are located on both front ends of the table top.

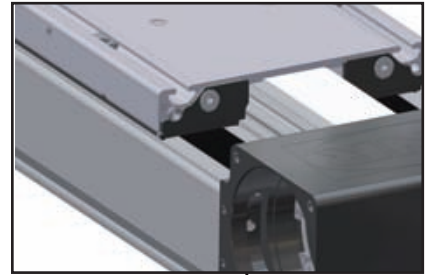
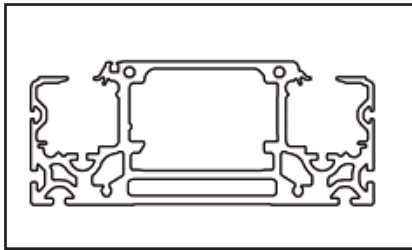

- **Seal**

The drive end of the synchronous belt axis is protected by a scraper brush.

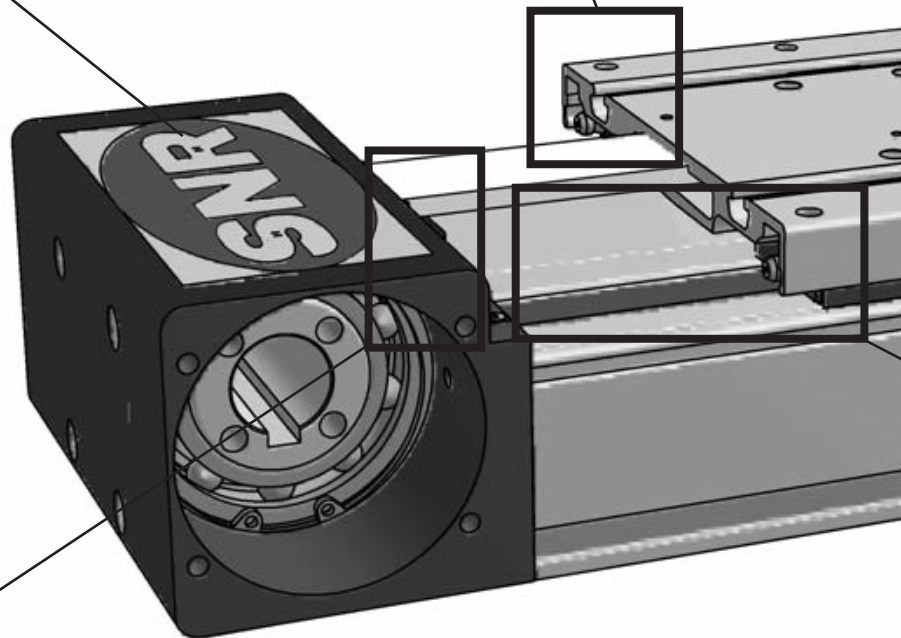
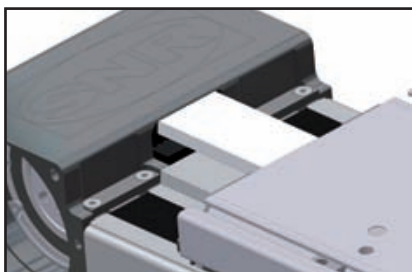

- **Ease of Service**

The modular design lowers maintenance costs during servicing. The synchronous belts, cover strips and return pulleys of the cover strips can be replaced without having to remove the table or the load.

- **Optional variants of drive and guidance system**

Alternative guidance systems consist of two parallel guides equipped with crossed rollers or two ball rail guides.

The steel shafts of the roller guide are anchored in the profile at an angle of 45°.

Available drive systems are a synchronous belt or precision ball screw.

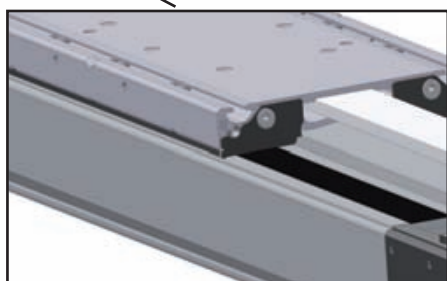
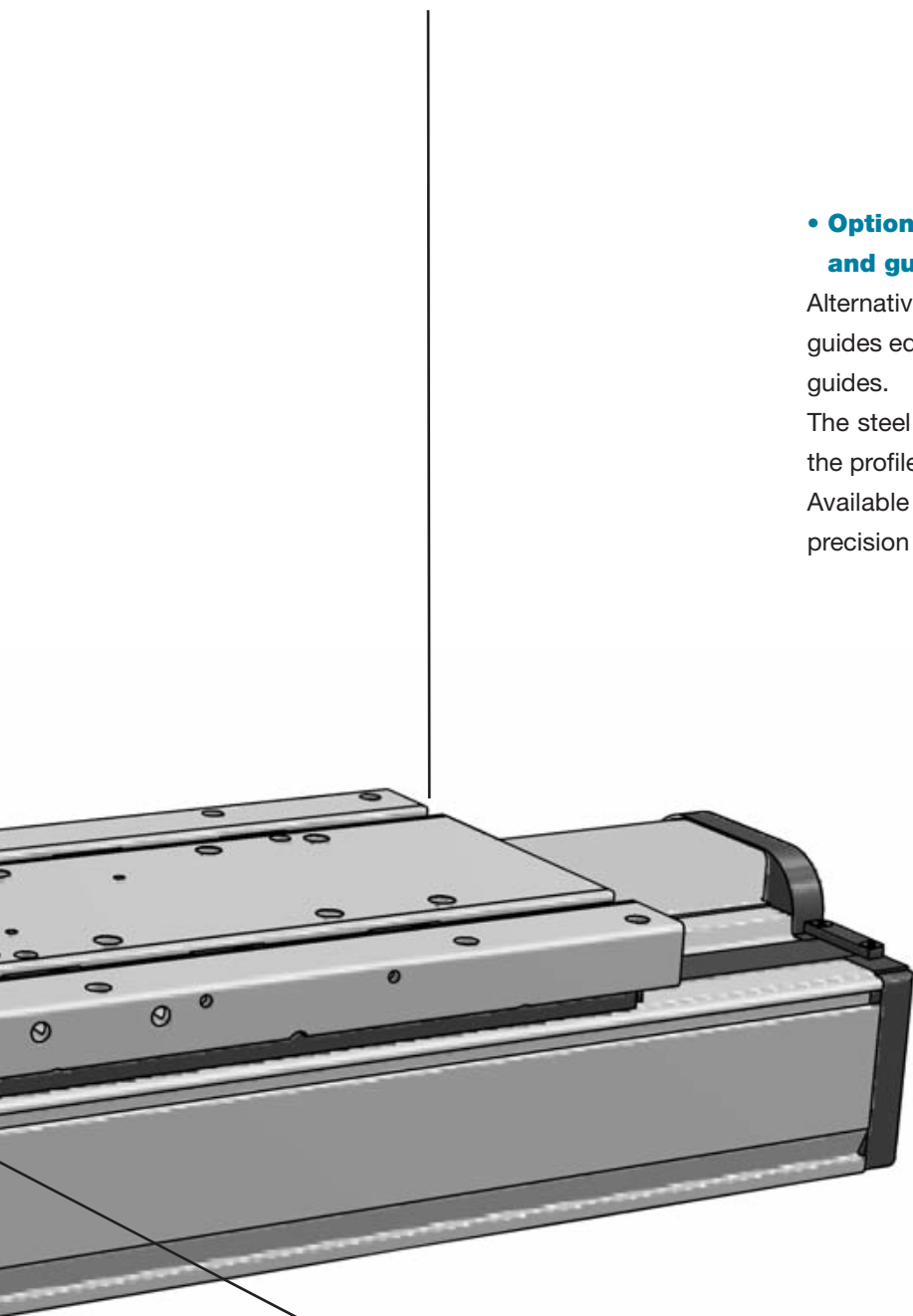

- **Seal**

Side gaskets on the table and specially shaped cover strips protect the guide and drive system from contamination. The cover strips are adapted to the table. Felt wipers safely remove contamination from cover strips and profile.

Moreover, the parallel modules can be supplied with a felt wiper and internal seals. This optional design offers more protection; the felt wiper removes debris from cover strips and the section.



I Linear tables

For applications with high loads, especially torque loads, SNR linear tables from the AXLT series provide excellent solutions.

The integrated ball screw drive ensures precise movements even under the highest loads. Two parallel ball rail systems ensure that high torque loads are safely absorbed. All internal components such as the screw-type drive, the guidance system and the switch may be protected from external forces by optional bellows.

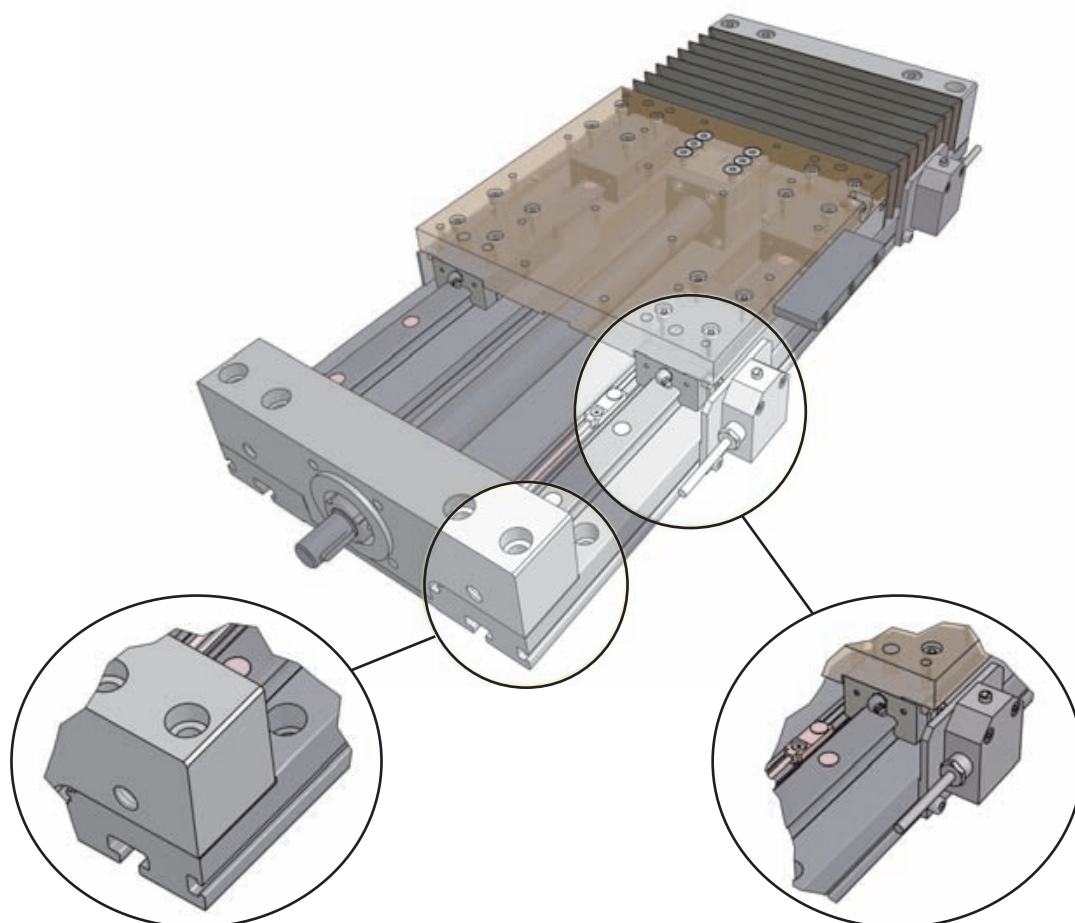

• Fastening

Depending on mounting position and size, our linear tables can be screwed from above or below using the sliding blocks, thanks to the structure of the base board.

• Limit switch sensors

Internal inductive proximity switches or externally attached mechanical limit switches are available as limit stop devices.

I Telescopic axes

SNR telescopic axes are distinguished by their optimally synchronized guidance systems and synchronous belt/rack and pinion drive combination.

They are especially suitable for use in confined installation spaces. Our modules are suitable for both vertical and horizontal applications, with the same dimensions and can achieve speeds of up to 10 m/s.

Telescopic axes can be delivered in combination with our gantry axes as a complete system or built into existing systems or new concepts as an individual module.

• Drive

Telescopic function through a combined drive comprising of a rack-and-pinion and synchronous belt drive.

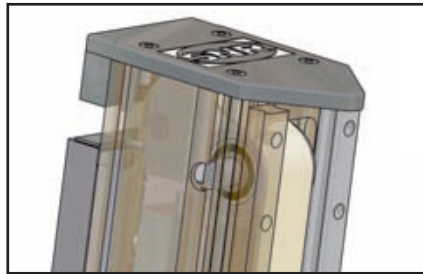
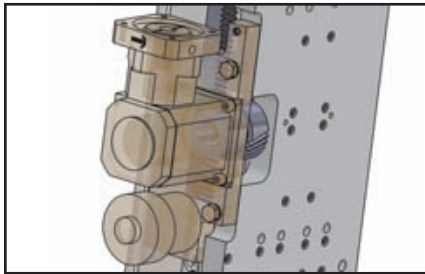

• Lubrication

Optimal lubricant supply is ensured for the rack and pinion drive by the use of a permanent lubrication system in combination with a felt-toothed wheel.

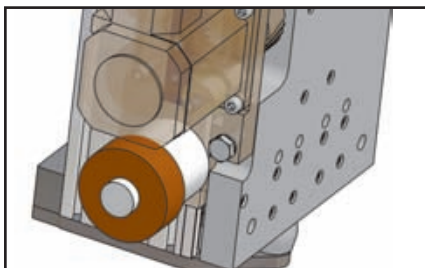

• Shock absorbers

Standard structural shock absorbers are used as mechanical limit switches.

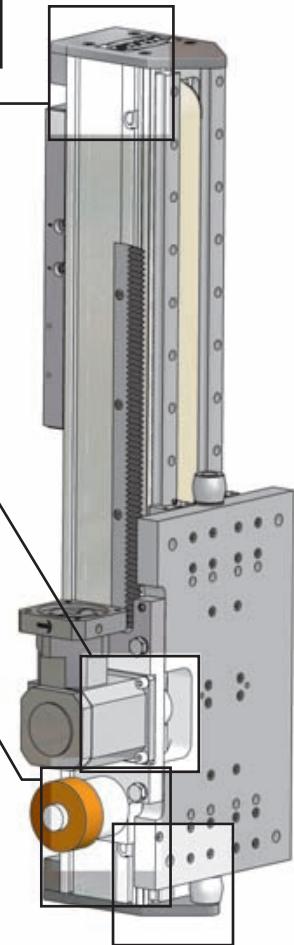
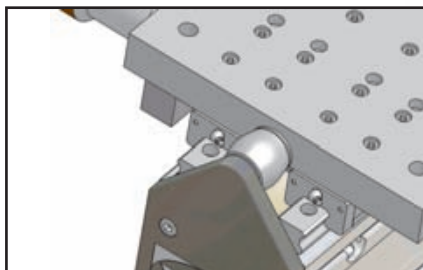



I Lifting axes with rack and pinion drive

SNR lifting axes are predominantly used in the field of vertical handling in linear and surface gantries due to the high dynamic load transmission capacity of the rack and pinion drive. Weights of up to 1000 kg can be moved thanks to the variable profile design and the rigid parallel construction of the ball rail system.

If vertical axes are used, we also recommend the use of newsletter No. 005 "Gravity-loaded axes (vertical axes)" 02/2004 edition from the technical committee on engineering, production systems, and steel construction.

In vertical axes, unintentional drop may be hazardous. To guarantee sufficient protection and reduce the hazard risk, a holding brake can be used as redundant element.

SNR lifting axis can be fitted with holding brakes, upon demand (see application example on page 123).

• Lubrication

Optimal lubricant supply is ensured for the rack and pinion drive through the use of a permanent lubrication system in combination with a felt-toothed wheel. Optionally, connection can also be made here to a central lubrication system.

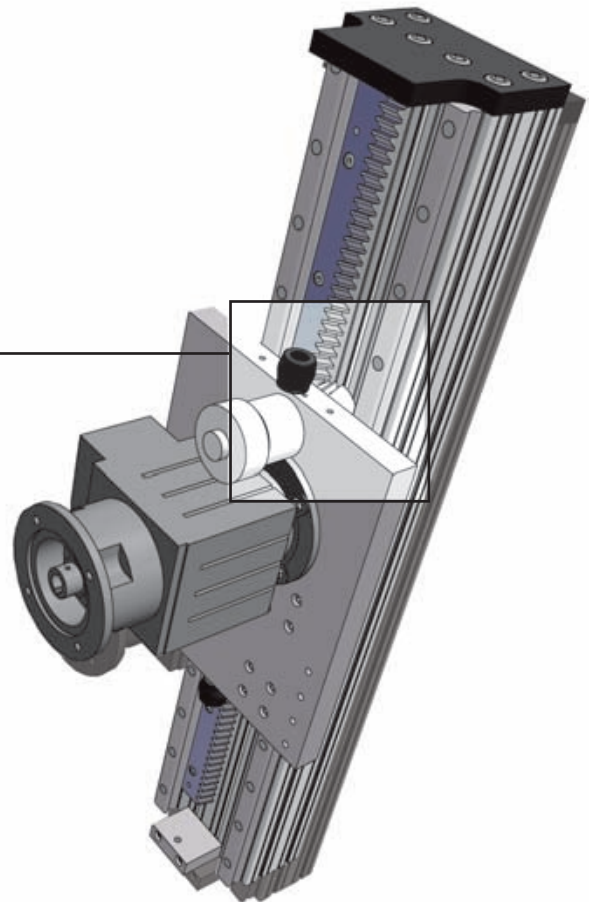
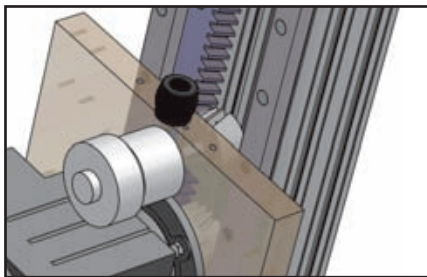

• Shock absorbers

In a vertical mounting position, structural shock absorbers are used for the mechanical stop position limit. These shock absorbers are dimensioned according to the maximum loads of the various installation sizes.

I Gantry axes

Gantry axes are characterized by high load capacity and total lengths of up to 10 m. Modules with synchronous belt drive are available for highly dynamic applications. Since ball rail guides are also used in these linear axes, they are distinguished by their exceptionally quiet running, even at high speeds. For applications where long lifting distances and the rigidity of the drive components are major considerations, our rack-and-pinion-driven linear axes offer multiple possibilities, since all the basic components, such as aluminum sections, guide bars and the rack and pinion can be extended to virtually any length to enable on-site assembly.

In these variants several carriage units can also be moved on one axis independently of each other.

• Damper

For SNR gantry axes, only hydraulic buffer shock absorbers are used as mechanical limit switches.

• Guidance system

Highest loads and smooth running performance due to parallel ball rail systems.

• Lubrication

Optimal lubricant supply is ensured for the rack and pinion drive through the use of a permanent lubrication system in combination with a felt-toothed wheel. Optionally, the connection can also be made here to a central lubrication system.

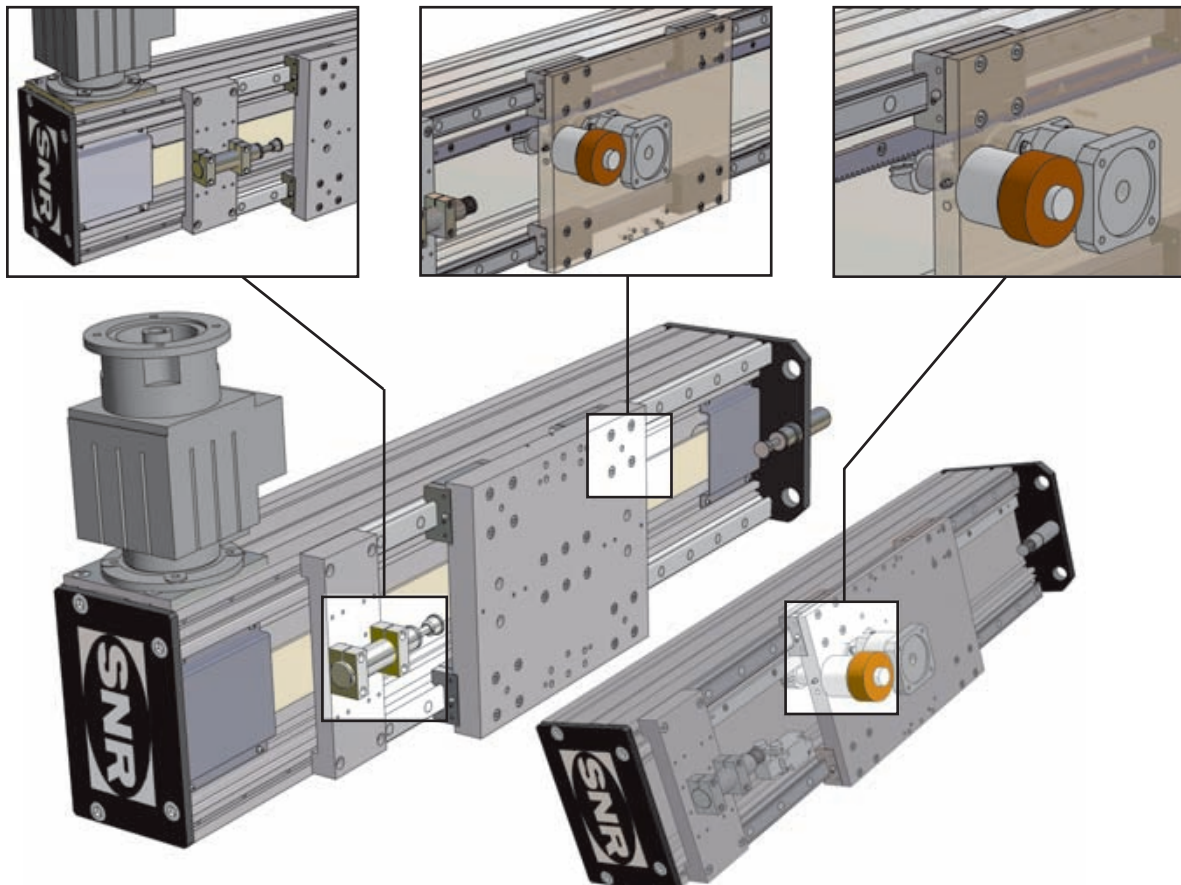



I Guidance systems

• Load-bearing capacities

The dynamic load-bearing capacities of both profile rail and roller guide systems are based on a nominal service life of 54,000 km for synchronous belt drives and 27,000 km for screw-type drives. Where static alternating loads are involved, the dynamic limit values need to be taken into account when sizing. Please consult our calculations department when dealing with unusual and complex loading situations.

• Caged ball linear guide

The AXC, AXDL, AXLT and AXS-series linear modules are fitted with caged ball rail systems.

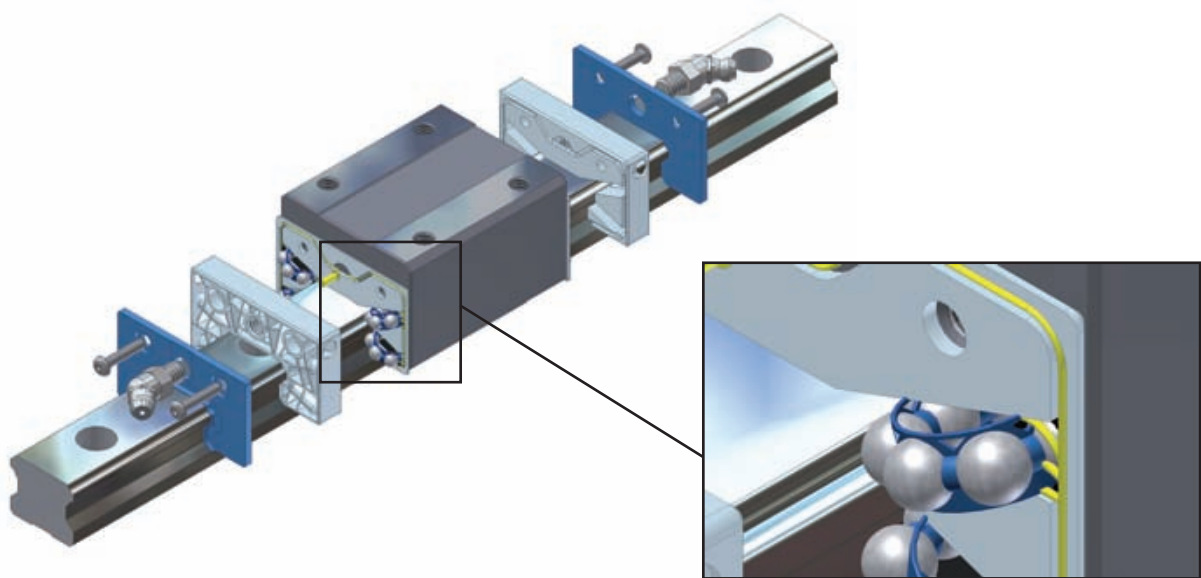

When the tracks are arranged at an angle of 45° SNR ball rails can be used on all systems and have the same load rating in all main load directions.

Other features of SNR caged ball rail system with integrated lubricant reservoir include:

- Long service life, maintenance-free over a long period, low heat generation
- High tolerance compensation and error compensation capacity through X arrangement of the rails.
- Low noise level, high running smoothness through additional distance balls on the chain ends.
- Speed up to 5 m/s, acceleration up to 50 m/s²

• **Roller guide**

All sizes from the AXC and AXDL series are also available in alternative versions with a roller guide system. This system consists of rollers which roll on burnished, tempered steel shafts incorporated in the aluminium section. The steel shafts are permanently supplied with lubricating oil from an oil reservoir that can be refilled from the outside.

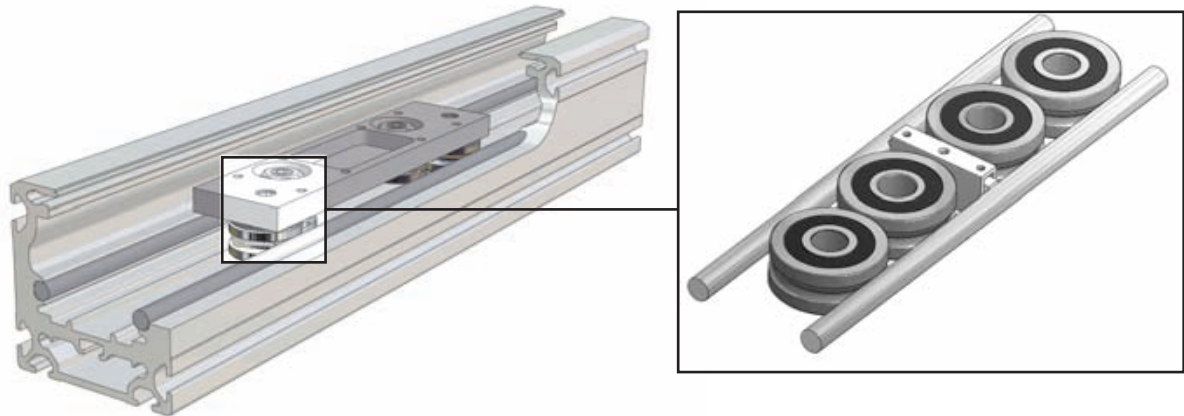

Thanks to the eccentric mounting of the two rollers the guidance system can be precisely adjusted, thus maintaining the correct initial preload or zero backlash set at the factory. This technology provides for excellent running properties.

• **Without guidance system**

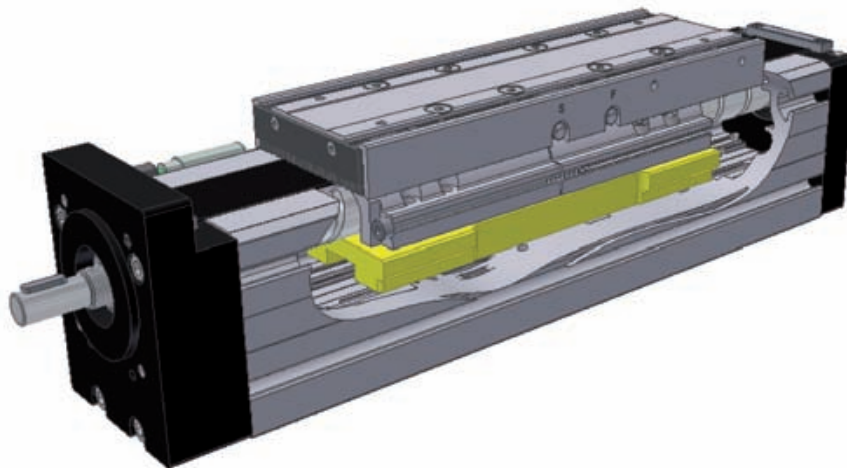

Linear axes without guidance system are referred to as feed axes. The difference between the feed axes and axes with rollers and rail guides is that forces can only be accommodated in the drive direction and it is not possible to handle moments.

Linear axes without a guidance system are used in applications in which a separate guidance system is required as a result of loads or rigidity requirements.



I The drive systems

- **Synchronous belt drive**

The synchronous belt drive is used primarily for fast handling and positioning tasks since speed is the primary objective. All sizes from the AXC series are equipped with AT-type synchronous belts.

- **Integrated pulleys**

The integrated pulleys allow an optimal ratio between lift and total length as well as a continuous aluminum section. The advantages for the user are an extremely compact installation and significantly greater flexibility in the fastening of the linear axis.

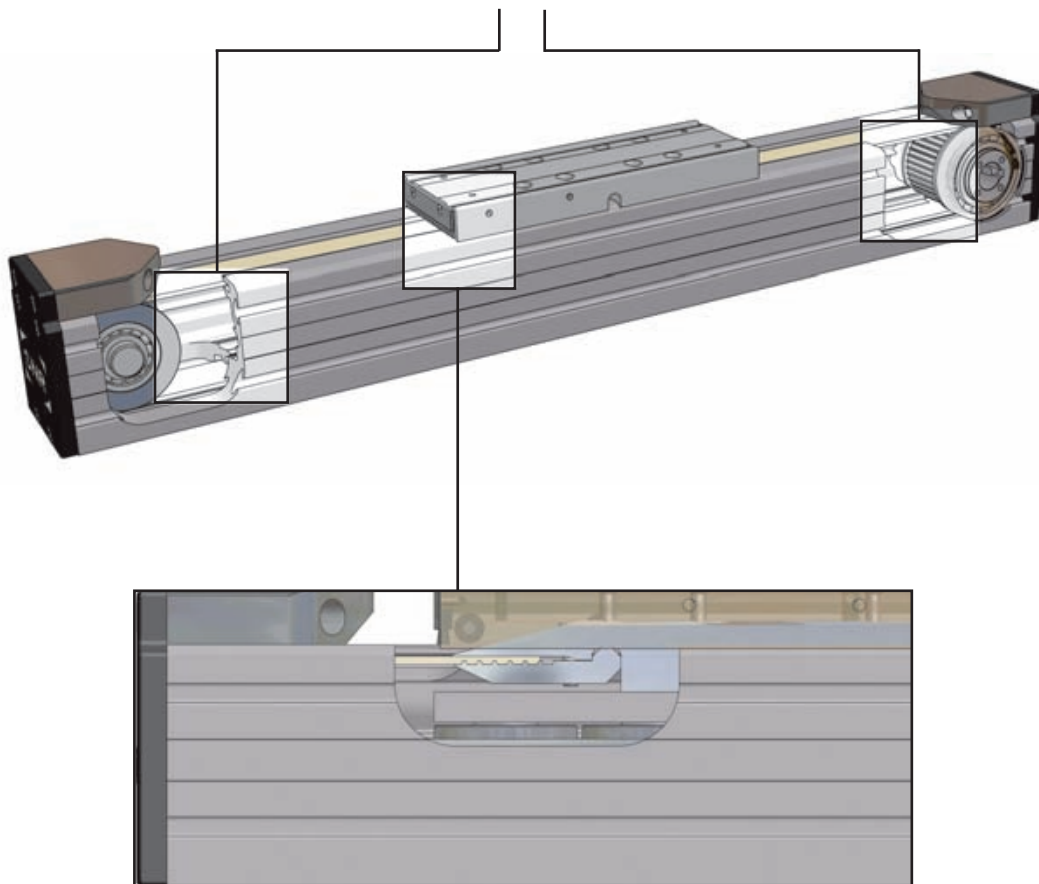

- **Synchronous belt clamping**

The belt clamp allows the high strength joining of the synchronous belt so that its full load-bearing capacity is retained.

• Synchronous belt drive in Omega design

The Omega drive is a variant of the synchronous belt drive.

• Belt clamping

The synchronous belt clamping is located at the ends of the linear axis where the entire belt width is used.

• Drive

The drive components (pulley, deflection pulleys) are built into the carriage.

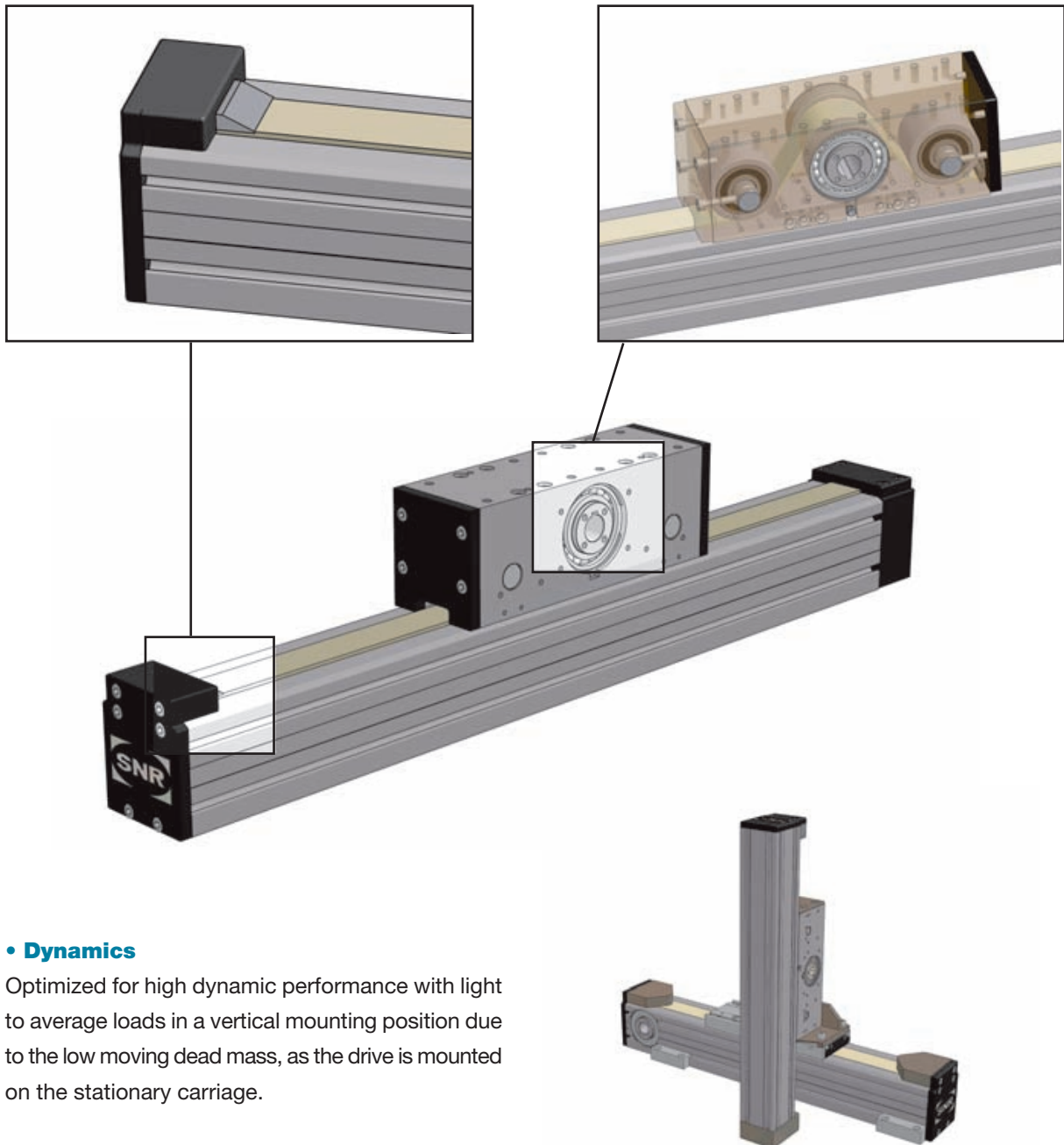

• Dynamics

Optimized for high dynamic performance with light to average loads in a vertical mounting position due to the low moving dead mass, as the drive is mounted on the stationary carriage.



I The drive systems

• Screw-type drive

Screw-type drives, especially ball screws, is used where high where high positioning and repeat accuracies are required in combination with high rigidity of the drive elements. Trapezoidal thread drives with various pitches are also available for simple low-speed movements.

• Spindle support

At higher speeds our screw-type drives are equipped with corresponding spindle supports to ensure secure operation.

• Accuracy / Quality

In the standard versions, our AXC and AXLT linear modules are equipped with rolled ball screw spindles (pitch accuracy: $52 \mu\text{m}/300 \text{ mm}$) and low-backlash nuts.

Ball screws with higher pitch accuracies and pre-stressed nuts are also available for more sophisticated positioning tasks.

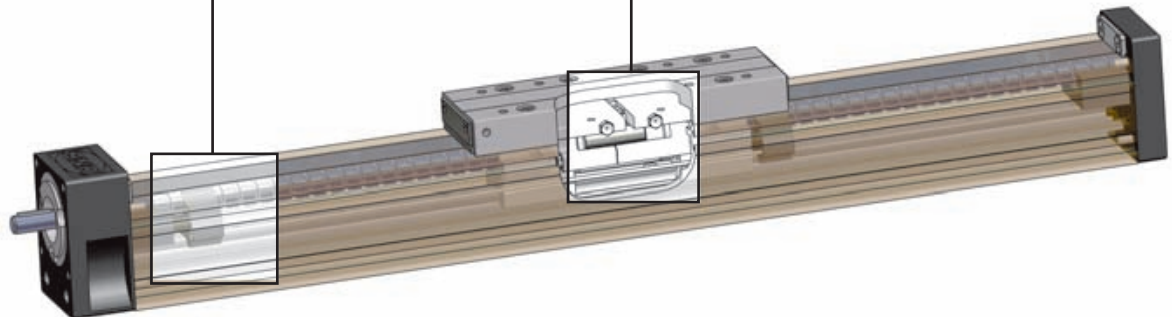
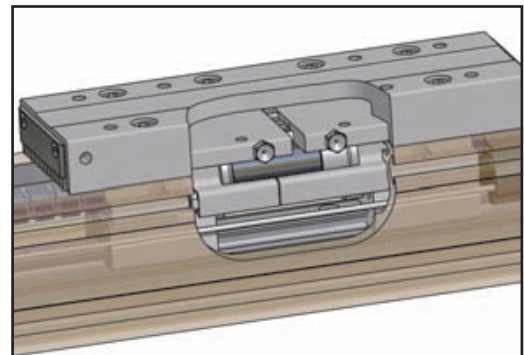
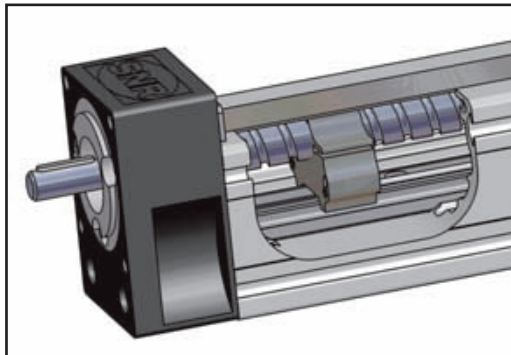

• Rack and pinion drive

Rack and pinion drives are available as another drive system for linear axes from the AXS series. Vertical applications in particular prove extremely reliable with this drive system.

• Long travel distances

Rack and pinion extensions can be added for theoretically unlimited travel distances.

• Rack and pinion / Gearwheel

Induction hardened racks and pinions and the associated gearwheels ensure high service life.

The rack and pinion drive offers the highest rigidity in a drive system, even under high loads.

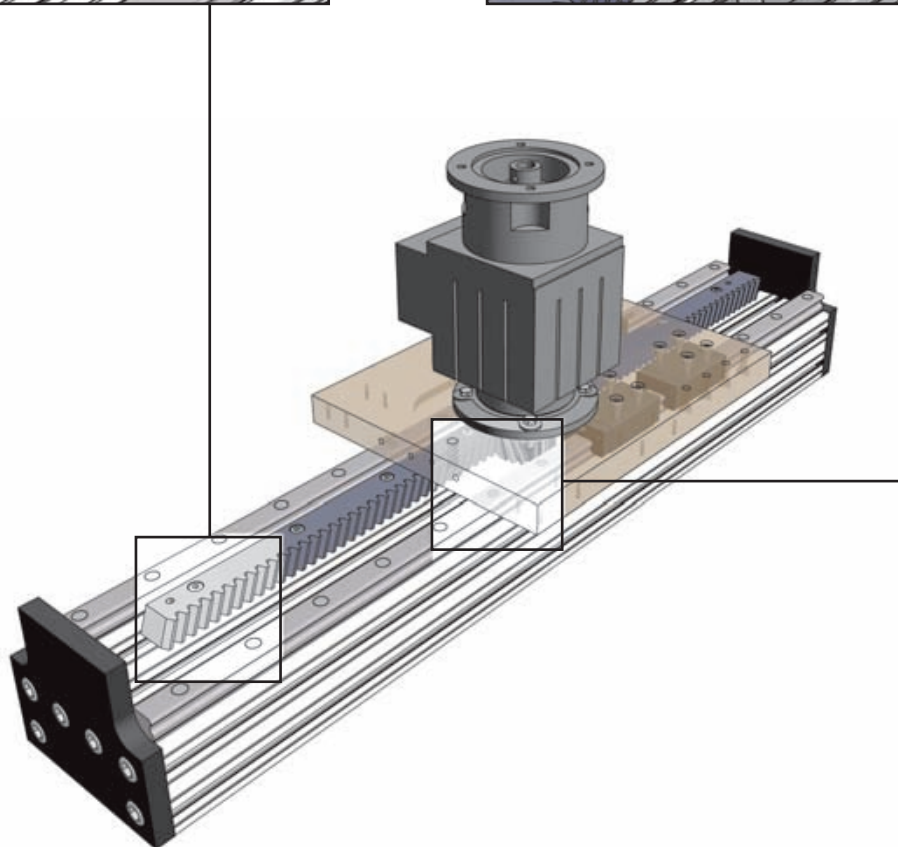
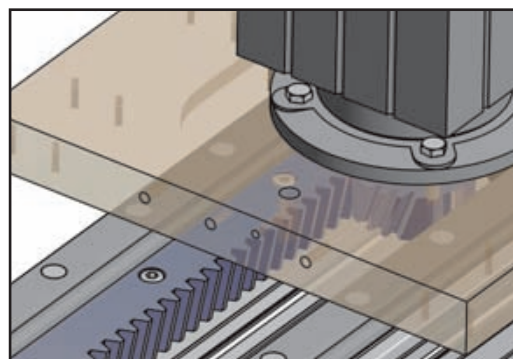
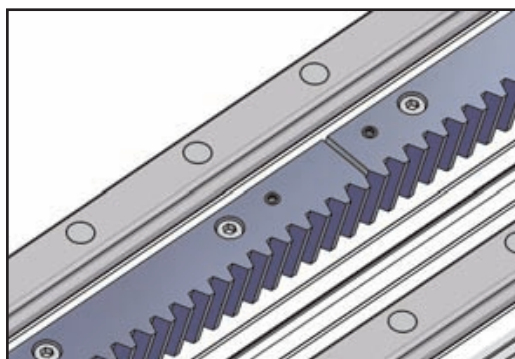

AXC40Z compact module

with synchronous belt drive and roller guide

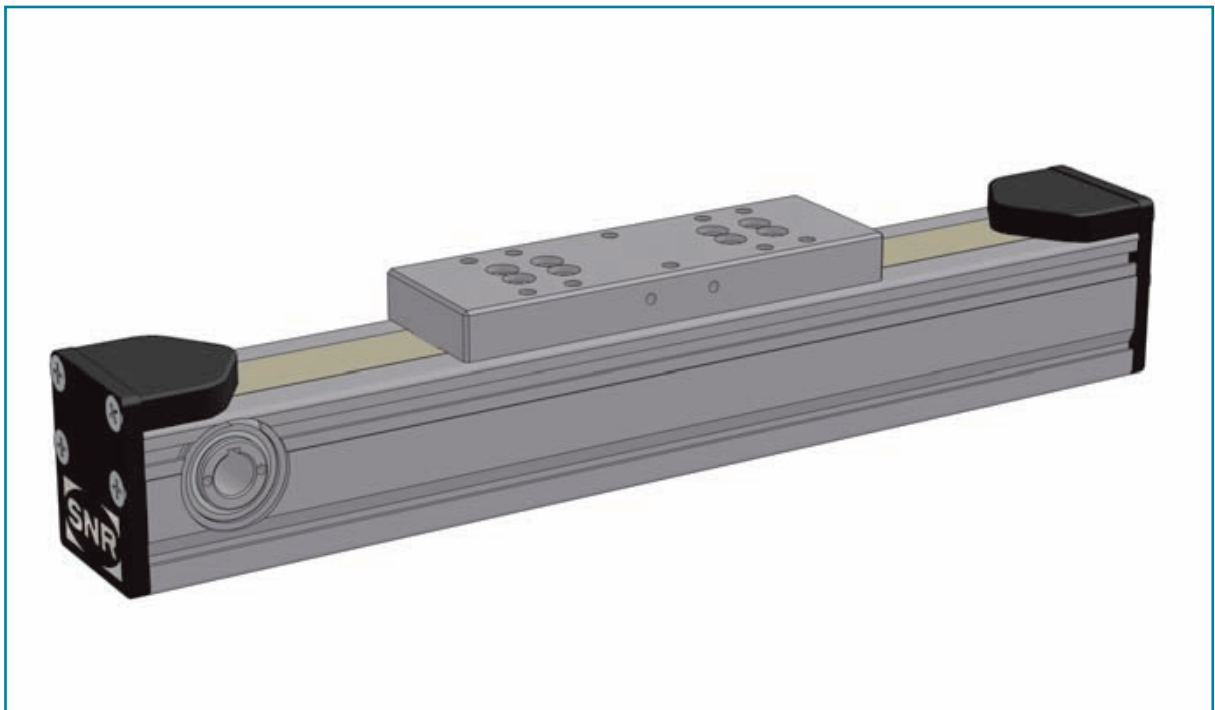
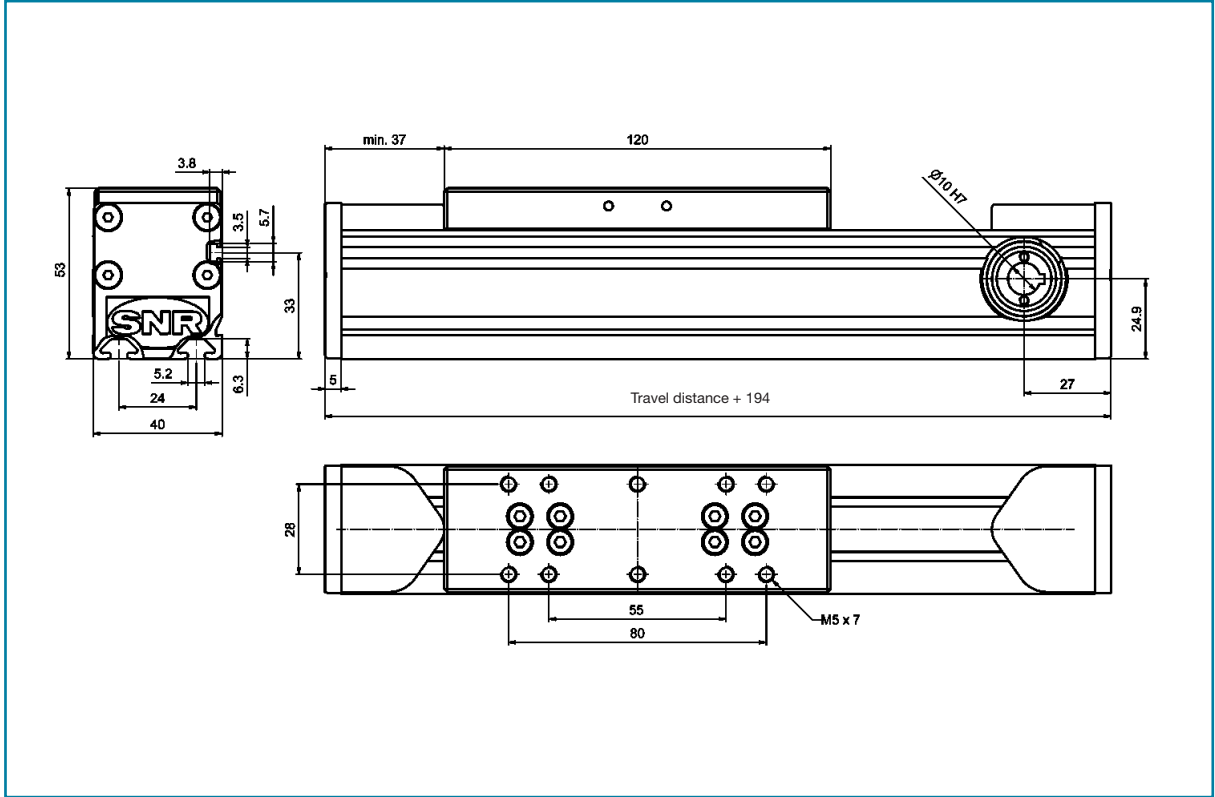

I Loads and torque loads

Roller guide		
ID number	L	
Table length [mm]	120	
Loads [N]	dyn.	stat.
F _y	310	330
F _z	170	300
-F _z	170	200
Torque loads [Nm]	dyn.	stat.
M _x	2,4	2,8
M _y	3,9	4,5
M _z	7	7,4

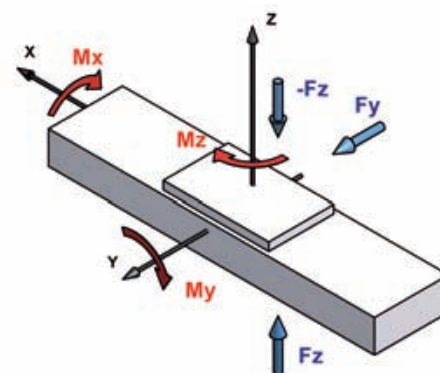

The dynamic load-bearing capacities of the guidance system are based on a nominal service life of 54,000 km.

I Technical specifications

Max. traverse rate [m/min]	600
Drive element	Synchronous belt 16AT3
Allowable. dyn. working load [N]	210
Lift per revolution [mm]	75
Idling speed torque [Nm]	0,16
Inertia [kgcm ²]	0,033
Geometrical moment of inertia I _y [cm ⁴]	9,521
Geometrical moment of inertia I _z [cm ⁴]	12,14
Maximal total length [m]	6 ¹⁾

1) Greater lengths upon request.

Roller guide	
ID number	L
Base mass [kg]	1,0
Mass per 100 mm of travel distance [kg]	0,2
Carriage mass [kg]	0,4



AXC40S compact module

with screw-type drives and profile rail
or roller guide

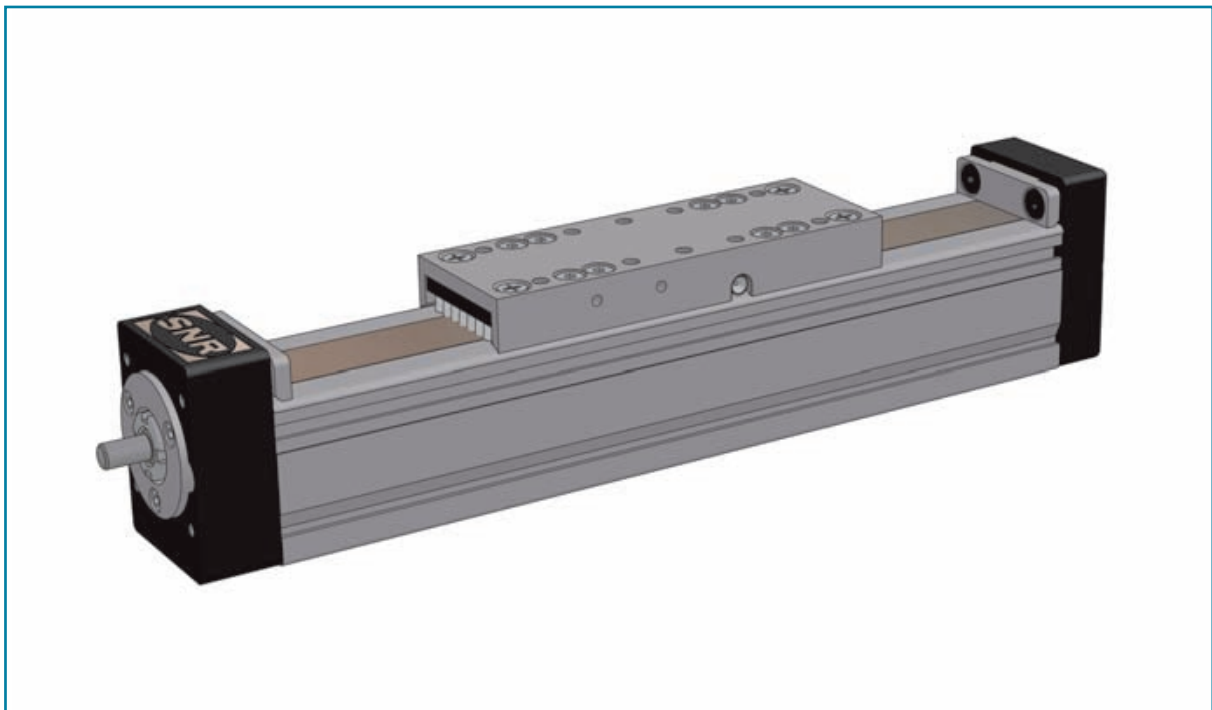
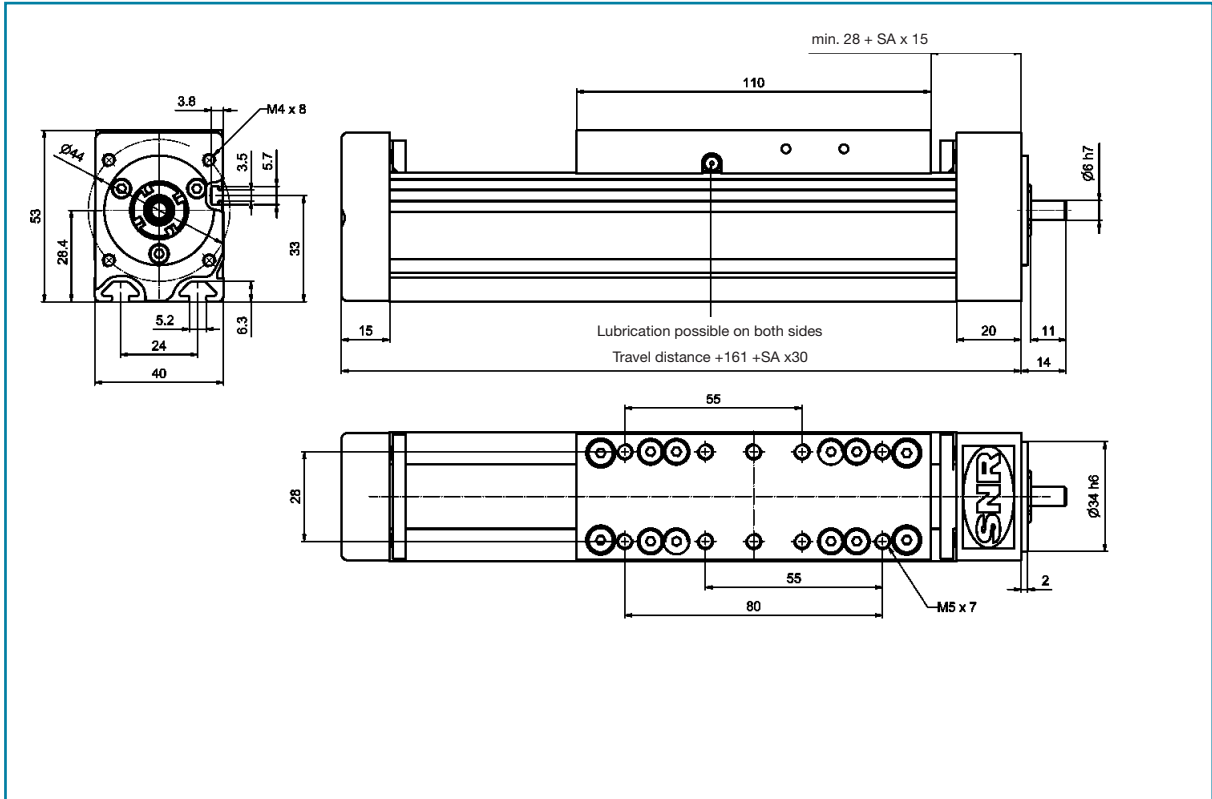

I Loads and torque loads

Caged ball linear guide		
ID number	B	
Table length [mm]	110	
Loads [N]	dyn.	stat.
Fy	660	910
Fz	660	910
-Fz	660	910
Torque loads [Nm]	dyn.	stat.
Mx	4,5	6
My	18	25
Mz	18	25

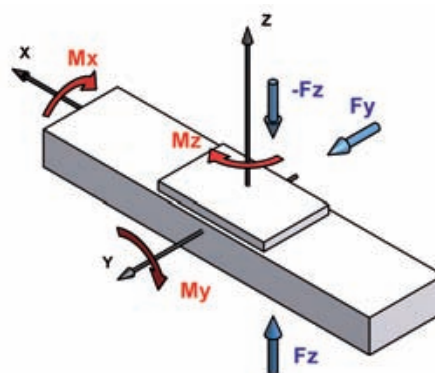

The dynamic load-bearing capacities of the guidance system are based on a nominal service life of 27,000 km.

I Technical specifications

Drive element	S1205	S1210	S1203
Pitch	5RH	10RH	3RH
Max. traverse rate [m/min]	30	60	5,5
Pitch accuracy [μ /300mm]	52		200
Dynamic load ratings screw-type drive [N]	3.600	2.500	-
Inertia [kgcm ² /m]	0,11	0,11	0,1
Idling speed torque [Nm]	0,3		
Geometrical moment of inertia Iy (profile) [cm ⁴]	9,251		
Geometrical moment of inertia Iz (profile) [cm ⁴]	12,14		
Maximal total length [m]	2,5		3,0
Profile bearing length ratio (nuts), [mm ²]	-		400
Efficiency	0,98	0,98	0,46

Caged ball linear guide	
ID number	B
Base mass [kg]	1,0
Mass per 100 mm of travel distance [kg]	0,3
Carriage mass [kg]	0,4

I Critical rotational speed for ball screws

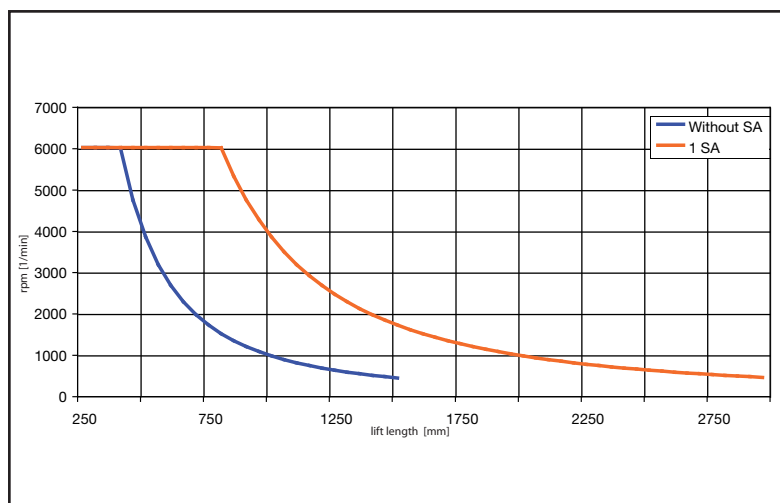

SA = set of spindle supports

Subject to technical modifications.

AXC60Z compact module

with synchronous belt drive and profile rail
or roller guide

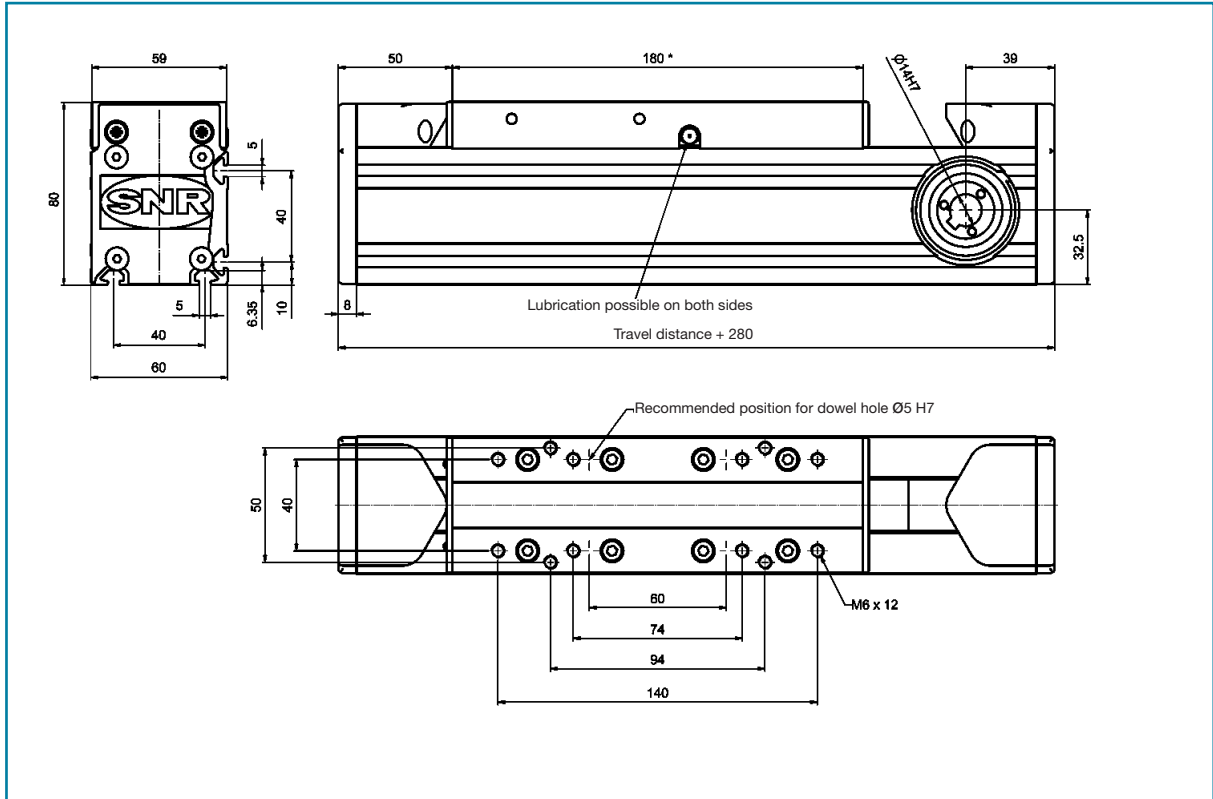

* Carriage length for design with cover strip: 230 mm.

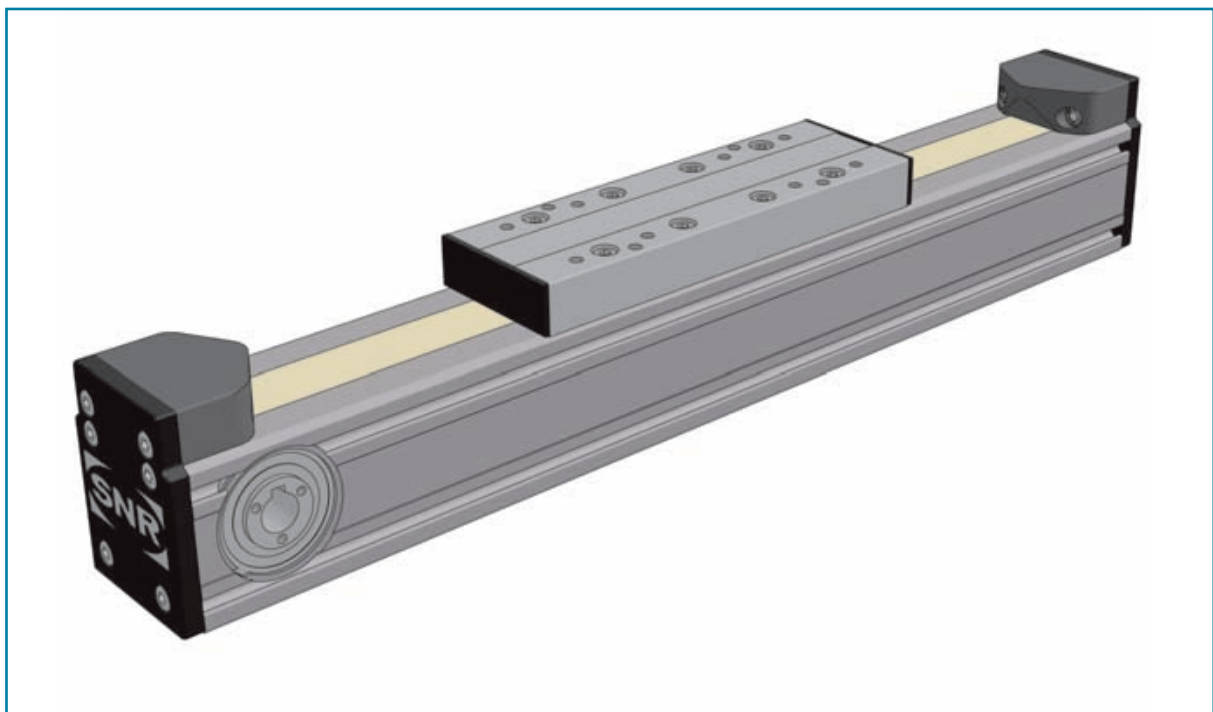

I Loads and torque loads

ID number	Roller guide		Caged ball linear guide	
	L		B	
Table length [mm]	180		180	
Loads [N]	dyn.	stat.	dyn.	stat.
F _y	840	840	2.750	9.650
F _z	500	550	2.750	9.650
-F _z	500	550	2.750	9.650
Torque loads [Nm]	dyn.	stat.	dyn.	stat.
M _x	10	10	19	69
M _y	27	27	95	345
M _z	41	41	95	345

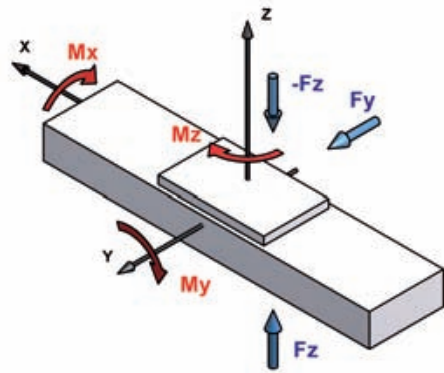

The dynamic load-bearing capacities of the guidance system are based on a nominal service life of 54,000 km.

I Technical specifications

Max. traverse rate [m/min]	600 (roller guide)
Drive element	Synchronous belt 25AT5
Allowable. dyn. working load [N]	560
Lift per revolution [mm]	150
Idling speed torque [Nm]	0,8
Inertia [kgcm ²]	0,74
Geometrical moment of inertia I _y [cm ⁴]	40,04
Geometrical moment of inertia I _z [cm ⁴]	60,64
Maximal total length [m]	6 (roller guide) 8 (caged ball rail)

ID number	Roller guide	Caged ball linear guide
	L	B
Base mass [kg]	2,6	2,9
Mass per 100 mm of travel distance [kg]	0,4	0,5
Carriage mass [kg]	1,0	1,1

Subject to technical modifications.

AXC60A compact module

with synchronous belt drive and profile rail
or roller guide

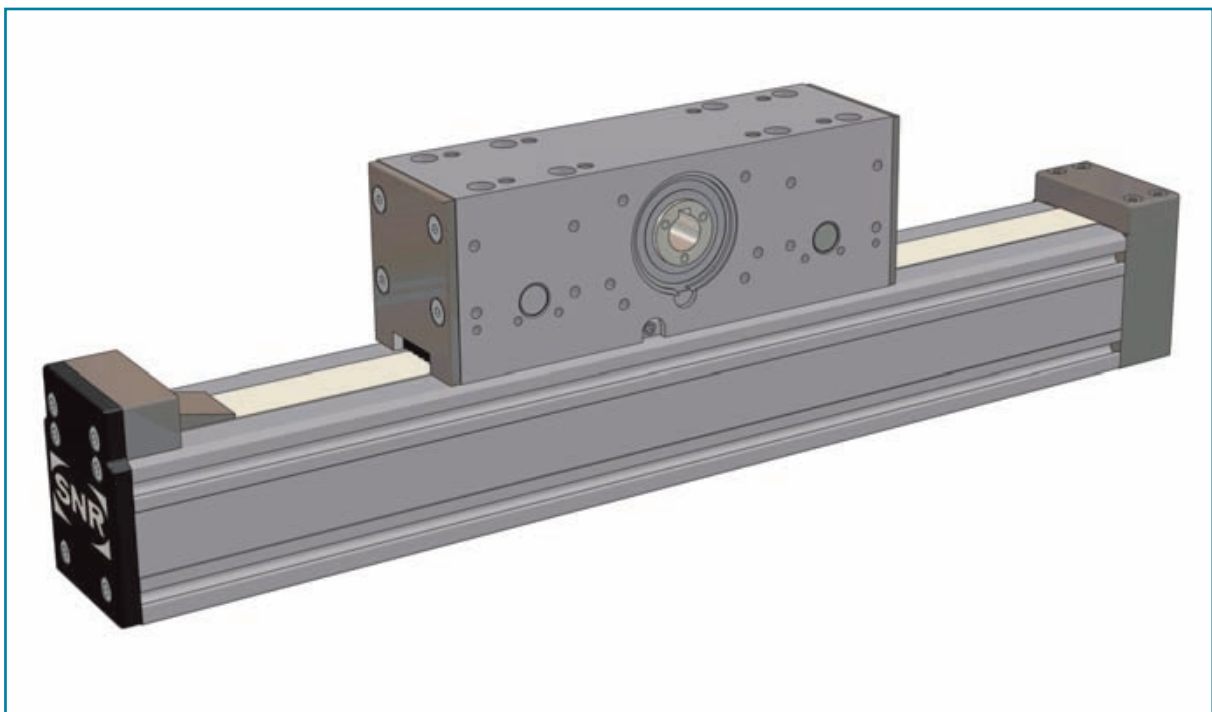
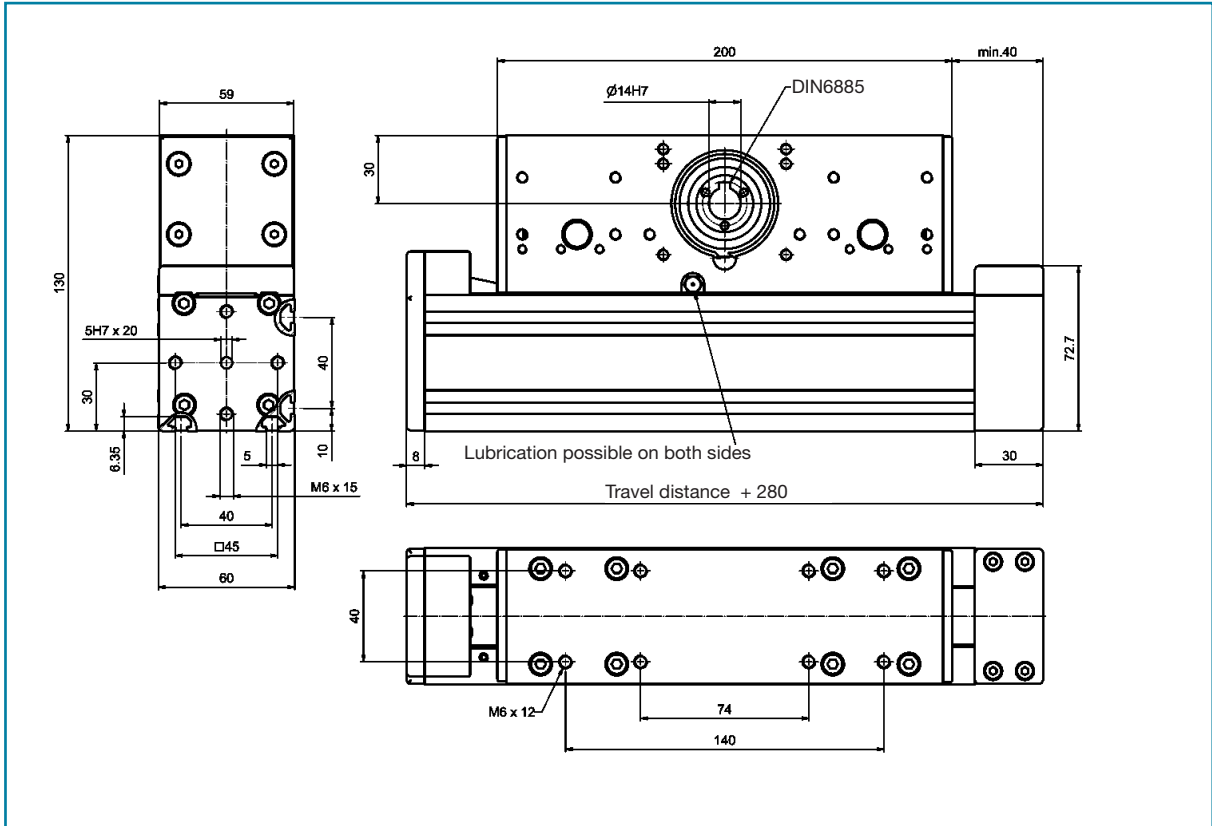

I Loads and torque loads

ID number	Roller guide		Ball rail guide	
	L	B	B	
Table length [mm]	200		200	
Loads [N]	dyn.	stat.	dyn.	stat.
F _y	840	840	2.750	9.650
F _z	500	550	2.750	9.650
-F _z	500	550	2.750	9.650
Torque loads [Nm]	dyn.	stat.	dyn.	stat.
M _x	10	10	19	69
M _y	27	27	95	345
M _z	41	41	95	345

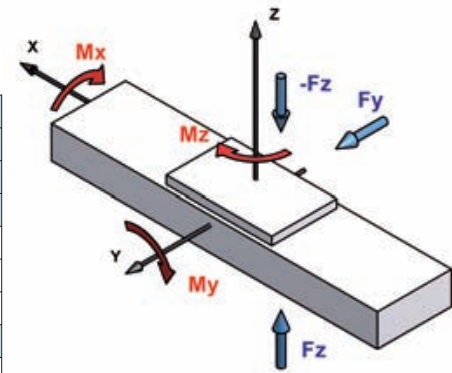

The dynamic load-bearing capacities of the guidance system are based on a nominal service life of 54,000 km.

I Technical specifications

Max. traverse rate [m/min]	600 (roller guide)
Drive element	Synchronous belt 25AT5
Allowable. dyn. working load [N]	560
Lift per revolution [mm]	150
Idling speed torque [Nm]	0,8
Inertia [kgcm ²]	1,07
Geometrical moment of inertia I _y [cm ⁴]	40,04
Geometrical moment of inertia I _z [cm ⁴]	60,64
Maximal total length [m]	6 (roller guide) 8 ¹⁾ (caged ball rail)

1) Greater lengths upon request.

ID number	Roller guide	Ball rail guide
	L	B
Base mass [kg]	2,6	4,6
Mass per 100 mm of travel distance [kg]	0,4	0,5
Carriage mass [kg]	2,6	2,7

Subject to technical modifications.

AXC60S compact module

with synchronous belt drive and profile rail
or roller guide

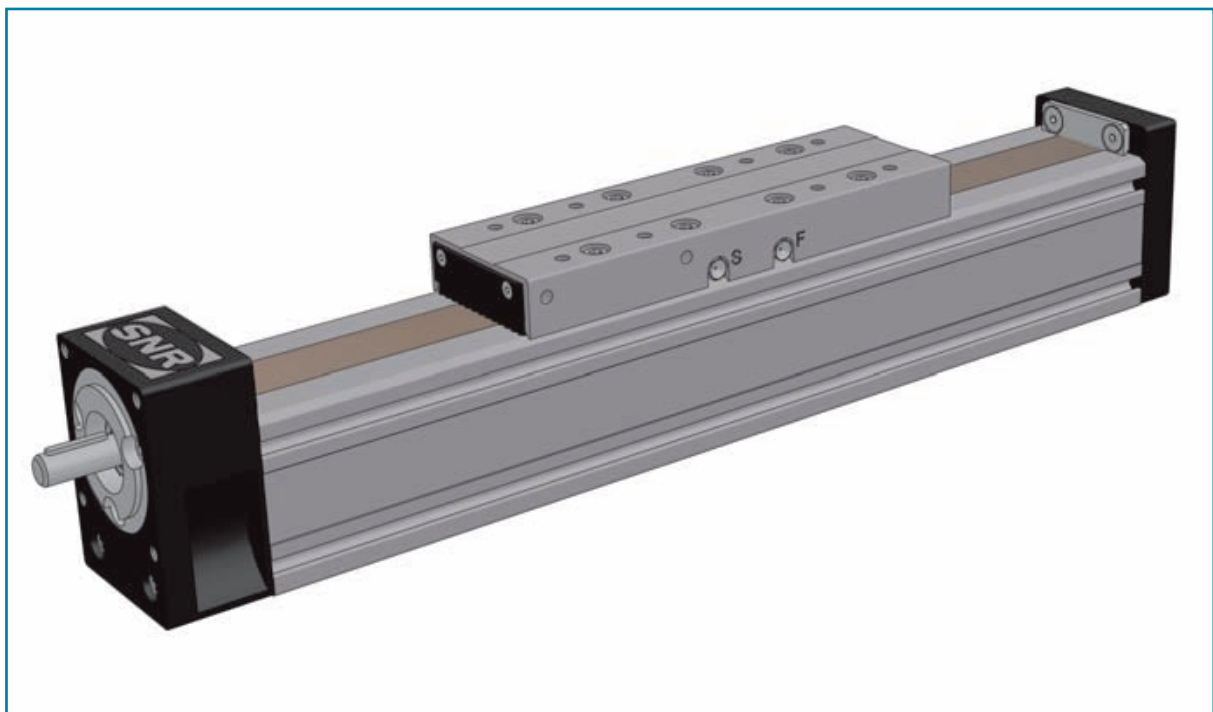
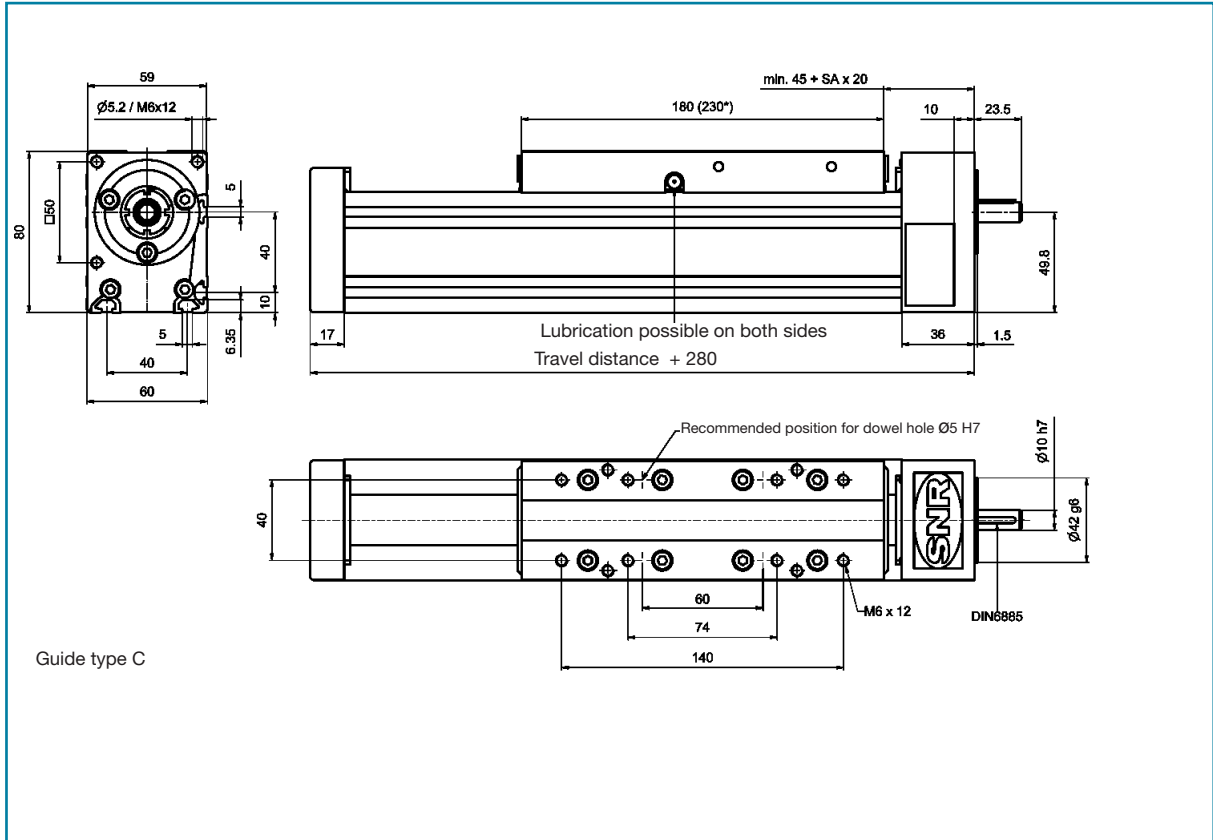

I Loads and torque loads

ID number	Roller guide		Ball rail guide			
	L		B		C	
Table length [mm]	180		180		230	
Loads [N]	dyn.	stat.	dyn.	stat.	dyn.	stat.
Fy	840	840	1.400	3.900	3.400	9.650
Fz	500	550	1.400	3.900	3.400	9.650
-Fz	500	550	3.900	3.900	3.400	9.650
Torque loads [Nm]	dyn.	stat.	dyn.	stat.	dyn.	stat.
Mx	10	10	10	27	24	69
My	27	27	65	185	200	570
Mz	41	41	65	185	200	570

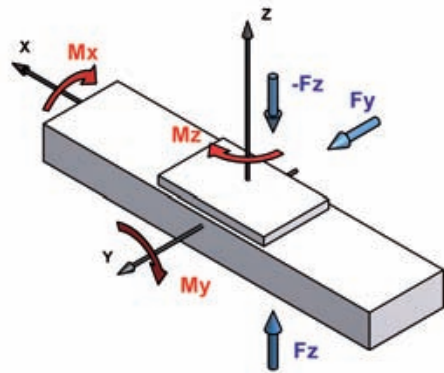

The dynamic load-bearing capacities of the guidance system are based on a nominal service life of 27,000 km.

I Technical specifications

Drive element	S1605	S1610	S1616	T1604	T1608
Pitch	5RH/LH	10RH	16RH	4RH/LH	8RH
Max. traverse rate [m/min]	30		96	5,5	10,9
Pitch accuracy [μ /300mm]	52		50	100	
Dynamic load ratings screw-type drive [N]	7.500	7.500	6.300	-	
	12.300*	9.600*			
Inertia [kgcm ² /m]	0,31	0,31	0,34	0,3	0,3
Idling speed torque [Nm]	0,4				
Geometrical moment of inertia Iy (profile) [cm ⁴]	40,04				
Geometrical moment of inertia Iz (profile) [cm ⁴]	60,64				
Maximal total length [m]	3,5			3	
Profile bearing length ratio (nuts), [mm ²]	-			490	
Efficiency	0,97	0,98	0,98	0,46	0,63

* with reinforced bearing

ID number	Roller guide	Ball rail guide	
	L	B	C
Base mass [kg]	2,60	2,7	3,40
Mass per 100 mm of travel distance [kg]	0,53	0,61	0,61
Carriage mass [kg]	0,90	0,8	1,2

I Critical rotational speed for ball screws

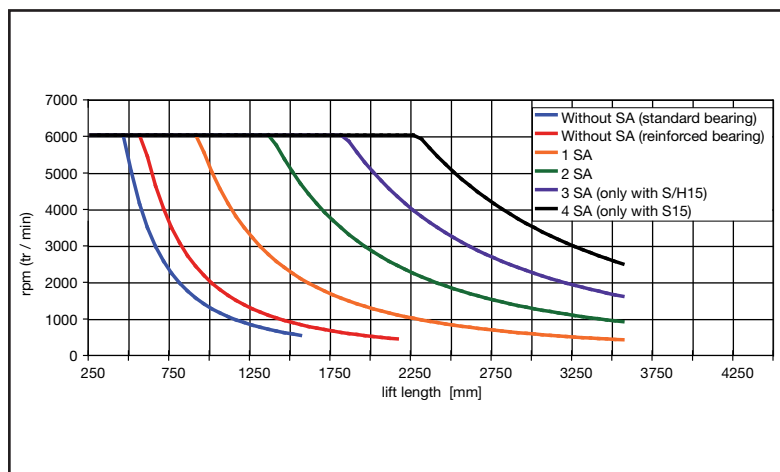

SA = set of spindle supports

Subject to technical modifications.

AXC80Z compact module

with synchronous belt drive and profile rail or roller guide

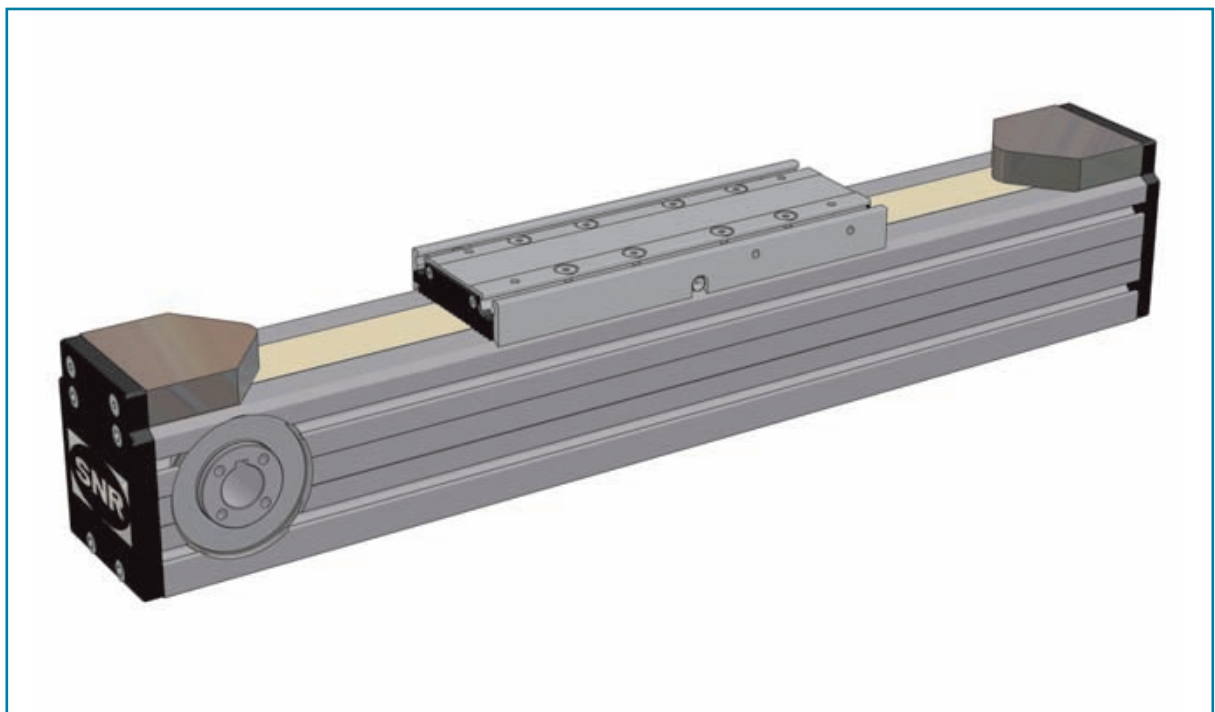
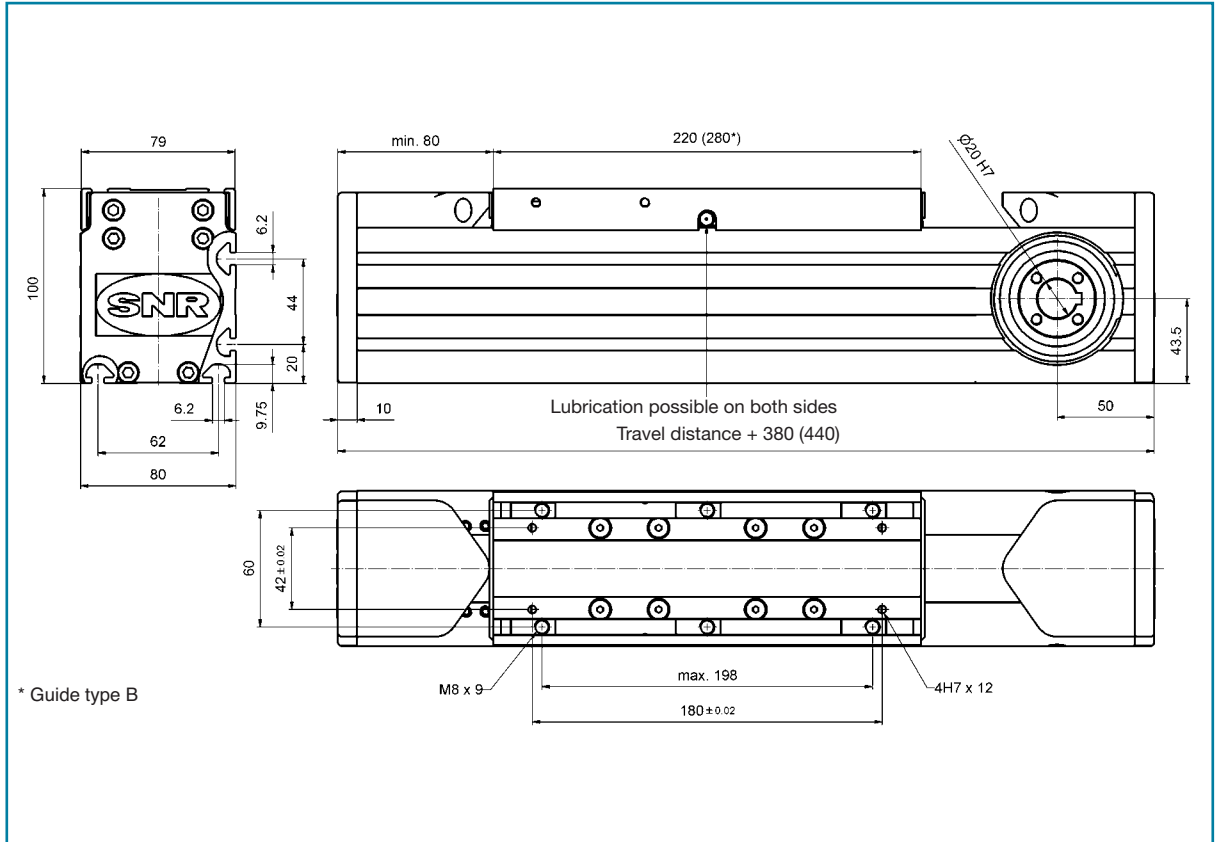

I Loads and torque loads

ID number	Roller guide		Ball rail guide			
	L		B		C	
Table length [mm]	220		220		280	
Loads [N]	dyn.	stat.	dyn.	stat.	dyn.	stat.
F _y	3.400	3.400	4.300	15.000	5.400	20.000
F _z	2.300	2.300	4.300	15.000	5.400	20.000
-F _z	2.300	2.300	4.300	15.000	5.400	20.000
Torque loads [Nm]	dyn.	stat.	dyn.	stat.	dyn.	stat.
M _x	60	60	43	150	43	150
M _y	110	110	205	730	310	1.140
M _z	170	170	205	730	310	1.140

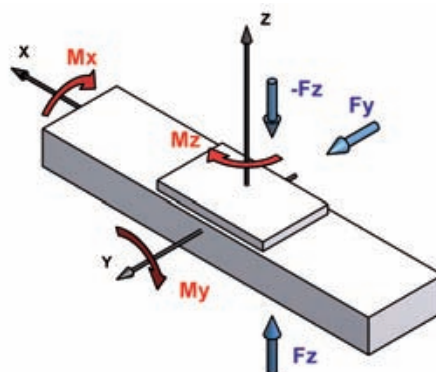

The dynamic load-bearing capacities of the guidance system are based on a nominal service life of 54,000 km.

I Technical specifications

Max. traverse rate [m/min]	600 (roller guide)
Drive element	Synchronous belt 32AT5
Allowable. dyn. working load [N]	870
Lift per revolution [mm]	200
Idling speed torque [Nm]	1,6
Inertia [kgcm ²]	3,68
Geometrical moment of inertia I _y [cm ⁴]	146,9
Geometrical moment of inertia I _z [cm ⁴]	199,2
Maximal total length [m]	8 (one) ¹⁾

1) Greater lengths upon request.

ID number	Roller guide		Ball rail guide			
	L		B		C	
Base mass [kg]	6,0		6,4		7,3	
Mass per 100 mm of travel distance [kg]	0,79		0,94		0,94	
Carriage mass [kg]	2,0		1,9		2,2	

Subject to technical modifications.

AXC80A compact module

with synchronous belt drive and profile rail or roller guide

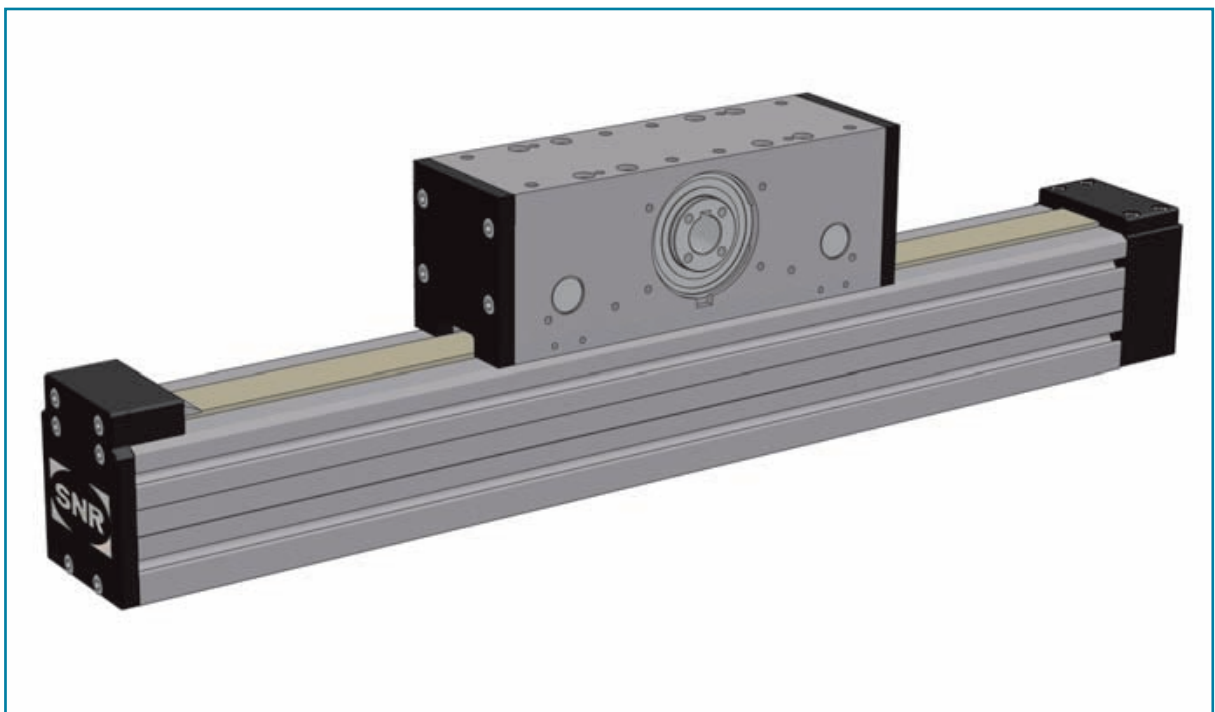
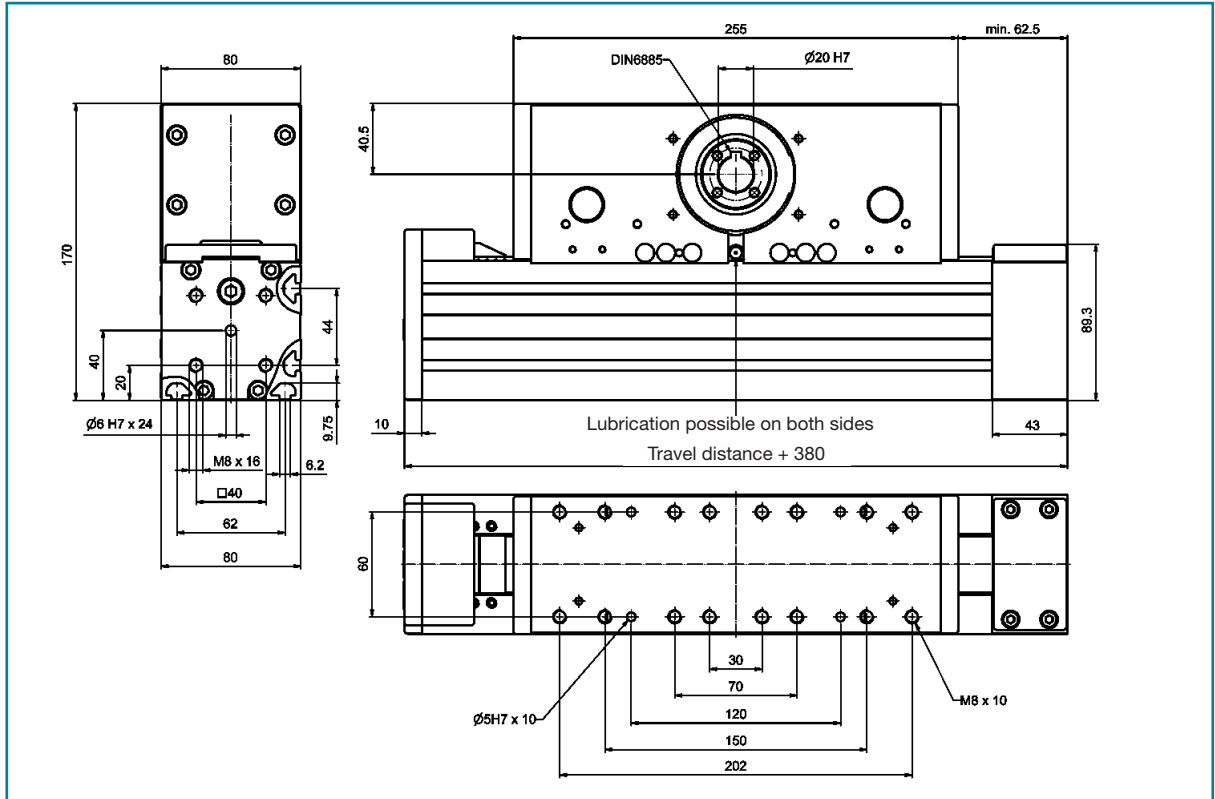

I Loads and torque loads

	Roller guide		Ball rail guide	
ID number	L		B	
Table length [mm]	255		255	
Loads [N]	dyn.	stat.	dyn.	stat.
F _y	3.400	3.400	4.300	15.000
F _z	2.300	2.300	4.300	15.000
-F _z	2.300	2.300	4.300	15.000
Torque loads [Nm]	dyn.	stat.	dyn.	stat.
M _x	60	60	43	150
M _y	110	110	205	730
M _z	170	170	205	730

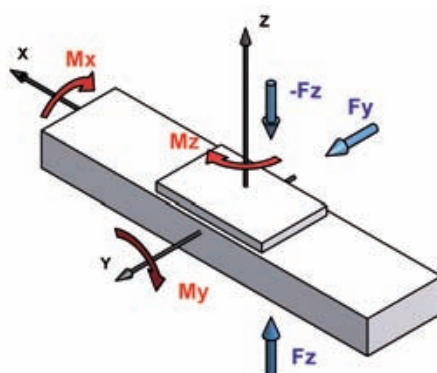

The dynamic load-bearing capacities of the guidance system are based on a nominal service life of 54,000 km.

I Technical specifications

Max. traverse rate [m/min]	600 (roller guide)
Drive element	Synchronous belt 32AT5
Allowable. dyn. working load [N]	870
Lift per revolution [mm]	200
Idling speed torque [Nm]	1,6
Inertia [kgcm ²]	5,0
Geometrical moment of inertia I _y [cm ⁴]	146,9
Geometrical moment of inertia I _z [cm ⁴]	199,2
Maximal total length [m]	8 (one part) ¹⁾

1) Greater lengths upon request.

	Roller guide	Ball rail guide
ID number	L	B
Base mass [kg]	10,0	10,6
Mass per 100 mm of travel distance [kg]	0,7	0,8
Carriage mass [kg]	5,5	5,9

Subject to technical modifications.

AXC80S compact module

with screw-type drive and profile rail
or roller guide

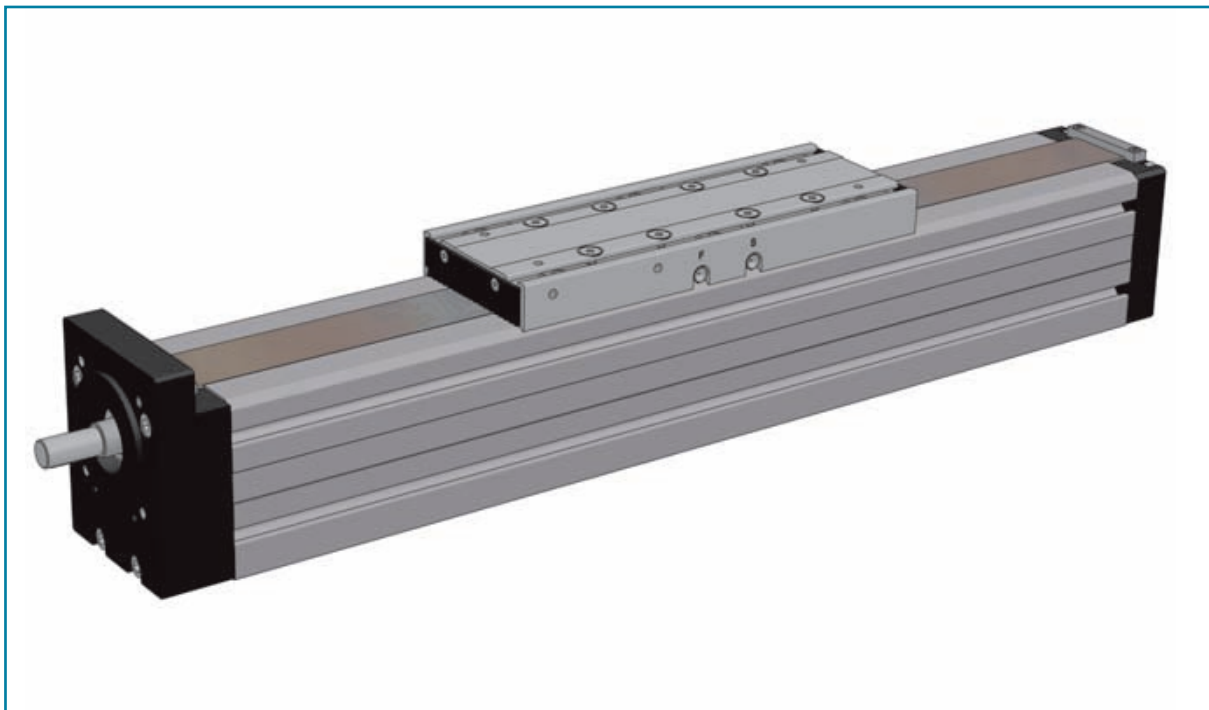
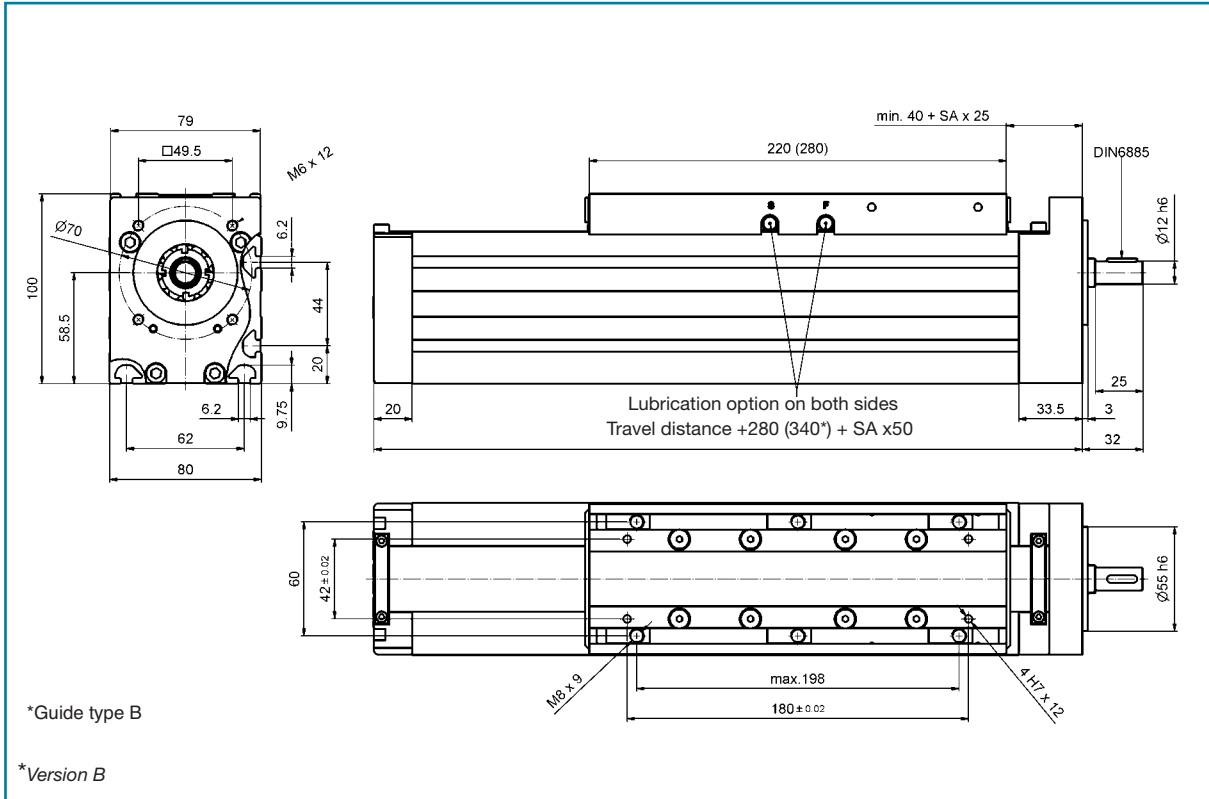

I Loads and torque loads

	Roller guide		Ball rail guide		no guidance (feed axis)	
ID number	L		B		F	
Table length [mm]	220		280		220	
Loads [N]	dyn.	stat.	dyn.	stat.	dyn.	stat.
Fy	1.000	1.000	5.400	15.000	-	-
Fz	1.400	1.400	5.400	15.000	-	-
-Fz	1.400	1.400	5.400	15.000	-	-
Torque loads [Nm]	dyn.	stat.	dyn.	stat.	dyn.	stat.
Mx	31	31	54	150	-	-
My	71	71	420	1.150	-	-
Mz	100	100	420	1.150	-	-

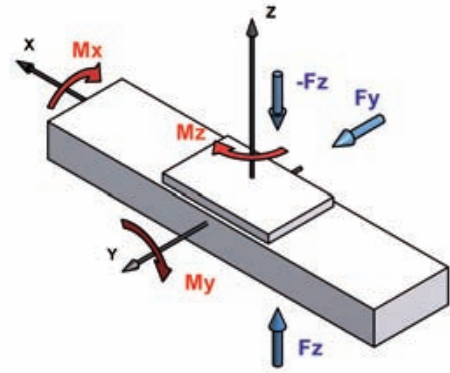

The dynamic load-bearing capacities of the guidance system are based on a nominal service life of 27,000 km.

I Technical specifications

Drive element	S2005	S2020	S2050	T2004	T2008
Pitch	5RH/>LH	20RH	50RH	4RH/LH	8RH
Max. traverse rate [m/min]	30	120	150	4,2	8,5
Pitch accuracy [μ /300mm]	52			50	100
Dynamic load ratings screw-type drive [N]	8.300	8.300	13.000	-	
	17.500*	13.300*			
Inertia [kgcm ² /m]	0,84	0,81	0,79	0,81	0,81
Idling speed torque [Nm]	0,4-0,6				
Geometrical moment of inertia Iy (profile) [cm ⁴]	146,9				
Geometrical moment of inertia Iz (profile) [cm ⁴]	199,2				
Maximal total length [m]	5,5				
Profile bearing length ratio (nuts), [mm ²]	-			870	
Efficiency	0,95	0,98	0,98	0,40	0,57

* with reinforced spindle supports

	Roller guide	Ball rail guide	no guidance (feed axis)
ID number	L	B	F
Base mass [kg]	5,1	6,3	4,8
Mass per 100 mm of travel distance [kg]	0,81	1,1	0,87
Carriage mass [kg]	1,7	1,7	1,4

I Critical rotational speed for ball screws

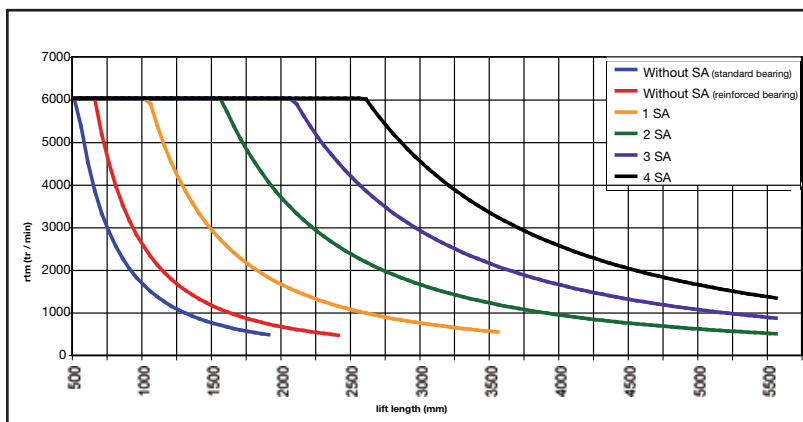

SA = set of spindle supports

Subject to technical modifications.

AXC120Z compact module

with synchronous belt drive and profile rail or roller guide

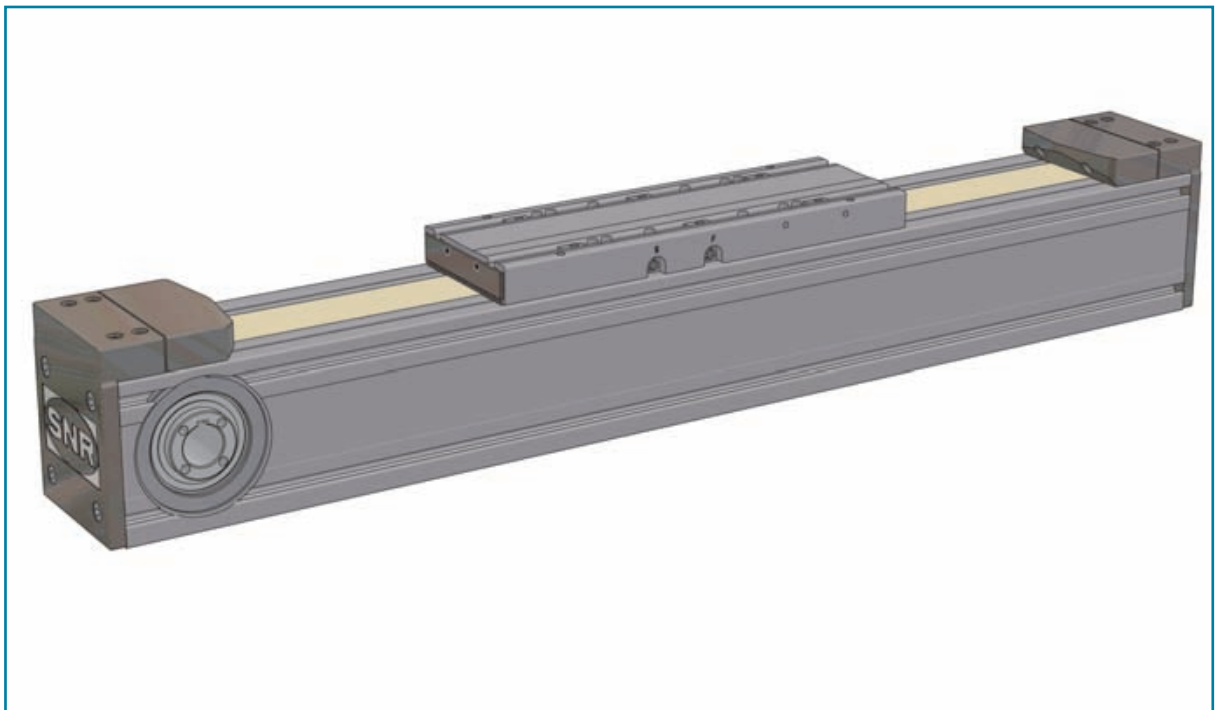
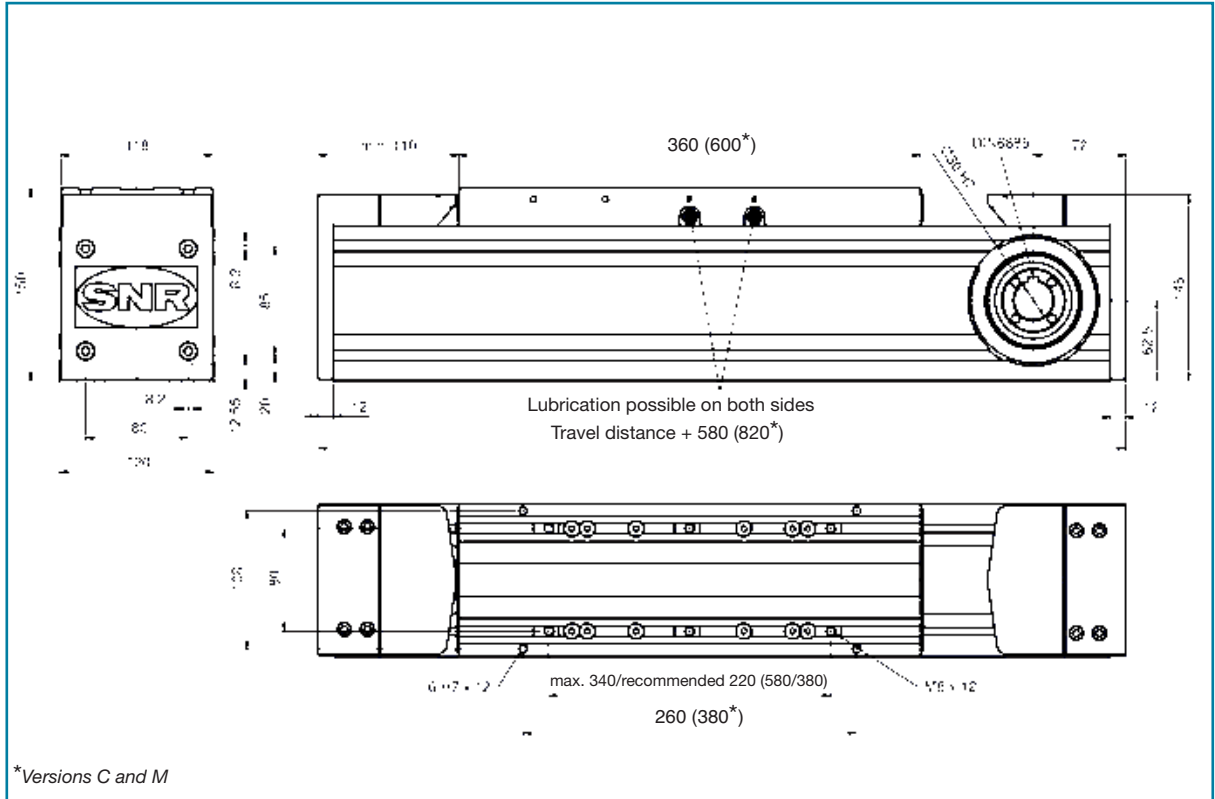

I Loads and torque loads

ID number	Roller guide				Ball rail guide			
	L		M		B		C	
Table length [mm]	360		600		360		600	
Loads [N]	dyn.	stat.	dyn.	stat.	dyn.	stat.	dyn.	stat.
Fy	5.100	5.100	6.800	6.800	8.700	26.500	10.500	35.500
Fz	3.400	3.400	4.500	4.500	8.700	26.500	10.500	35.500
-Fz	3.400	3.400	4.500	4.500	8.700	26.500	10.500	35.500
Torque loads [Nm]	dyn.	stat.	dyn.	stat.	dyn.	stat.	dyn.	stat.
Mx	110	110	150	150	120	365	145	490
My	260	260	530	530	730	2.250	1.750	5.900
Mz	390	390	790	790	730	2.250	1.750	5.900

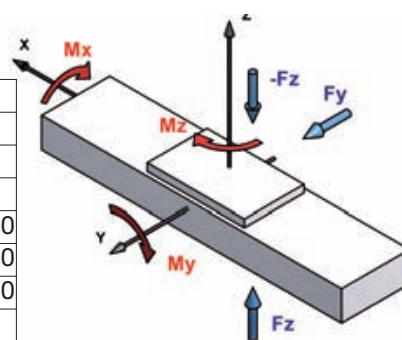

The dynamic load-bearing capacities of the guidance system are based on a nominal service life of 54,000 km.

I Technical specifications

Max. traverse rate [m/min]	600 (roller guide)
Drive element	Synchronous belt 50AT10
Allowable. dyn. working load [N]	2500
Lift per revolution [mm]	320
Idling speed torque [Nm]	4
Inertia [kgcm ²]	29,9
Geometrical moment of inertia Iy [cm ⁴]	661,10
Geometrical moment of inertia Iz [cm ⁴]	938,57
Maximal total length [m]	8 (one part) ¹⁾

1) Greater lengths upon request.

ID number	Roller guide		Ball rail guide	
	L	M	B	C
Base mass [kg]	20,1	28,5	21,6	30,0
Mass per 100 mm of travel distance [kg]	1,4	1,4	2,1	2,1
Carriage mass [kg]	6,2	11,3	6,4	9,8

Subject to technical modifications.



AXC120A compact module

with synchronous belt drive and profile rail
or roller guide

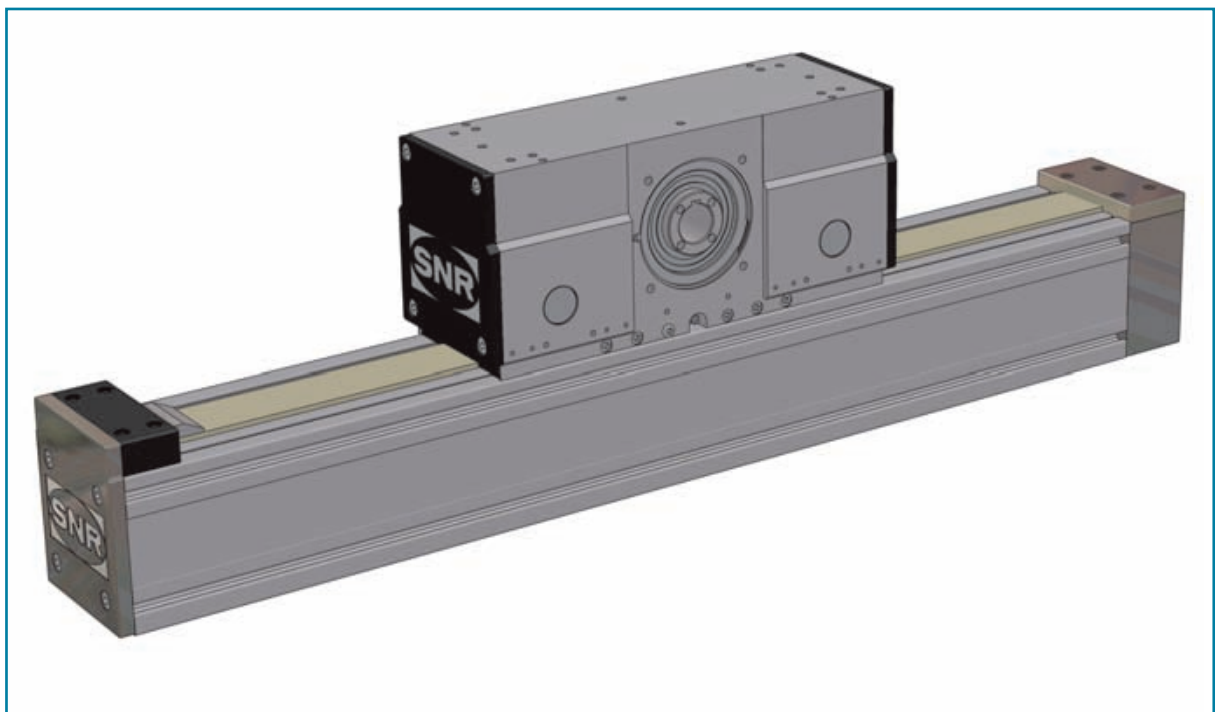
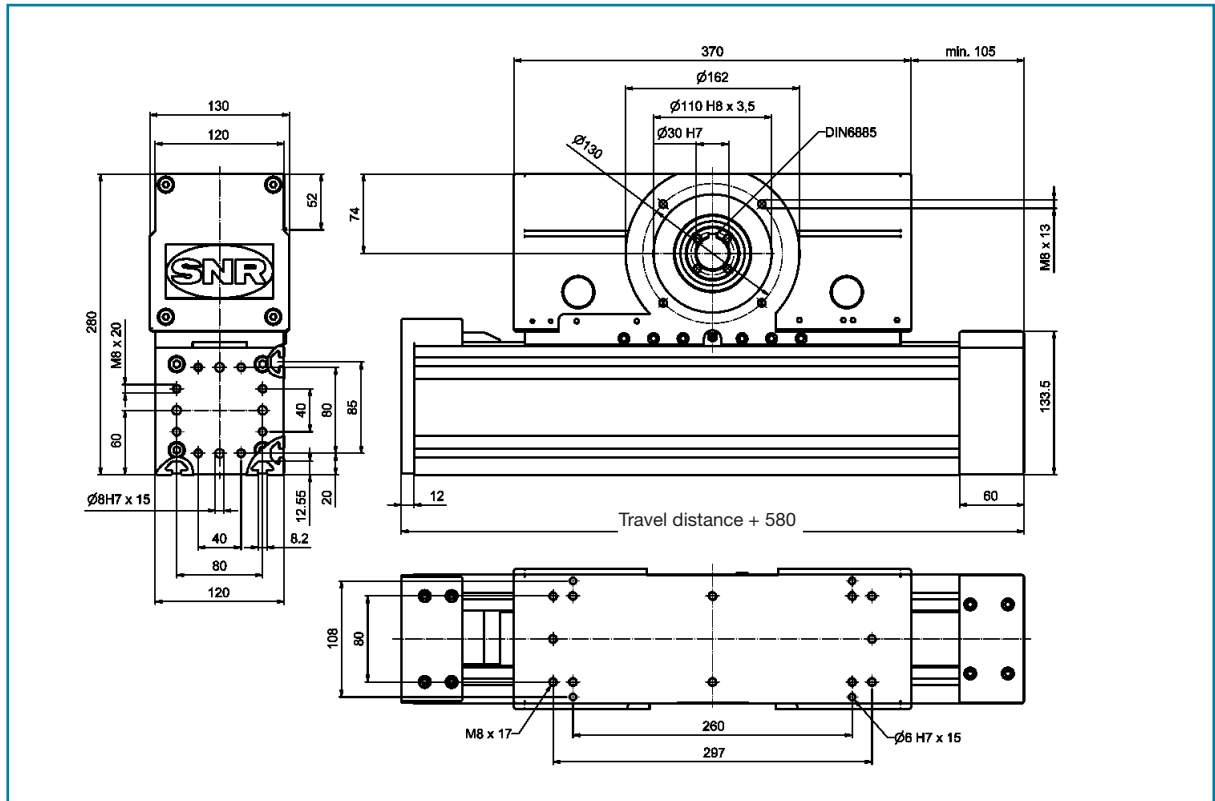

I Loads and torque loads

ID number	Roller guide		Ball rail guide	
	L		B	
Table length [mm]	370		370	
Loads [N]	dyn.	stat.	dyn.	stat.
F _y	3.400	3.400	4.300	15.000
F _z	2.300	2.300	4.300	15.000
-F _z	2.300	2.300	4.300	15.000
Torque loads [Nm]	dyn.	stat.	dyn.	stat.
M _x	60	60	43	150
M _y	110	110	205	730
M _z	170	170	205	730

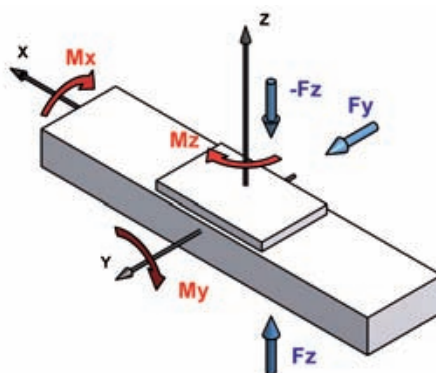

The dynamic load-bearing capacities of the guidance system are based on a nominal service life of 54,000 km.

I Technical specifications

Max. traverse rate [m/min]	600 (roller guide)
Drive element	Synchronous belt 50AT10
Allowable. dyn. working load [N]	2.500
Lift per revolution [mm]	320
Idling speed torque [Nm]	4
Inertia [kgcm ²]	73,7
Geometrical moment of inertia I _y [cm ⁴]	661,10
Geometrical moment of inertia I _z [cm ⁴]	938,57
Maximal total length [m]	8 (one part) ¹⁾

1) Greater lengths upon request.

ID number	Roller guide	Ball rail guide
	L	B
Base mass [kg]	23,4	24,9
Mass per 100 mm of travel distance [kg]	1,4	2,1
Carriage mass [kg]	12,8	13,0

Subject to technical modifications.

AXC120S compact module

with screw-type drive and profile rail
or roller guide

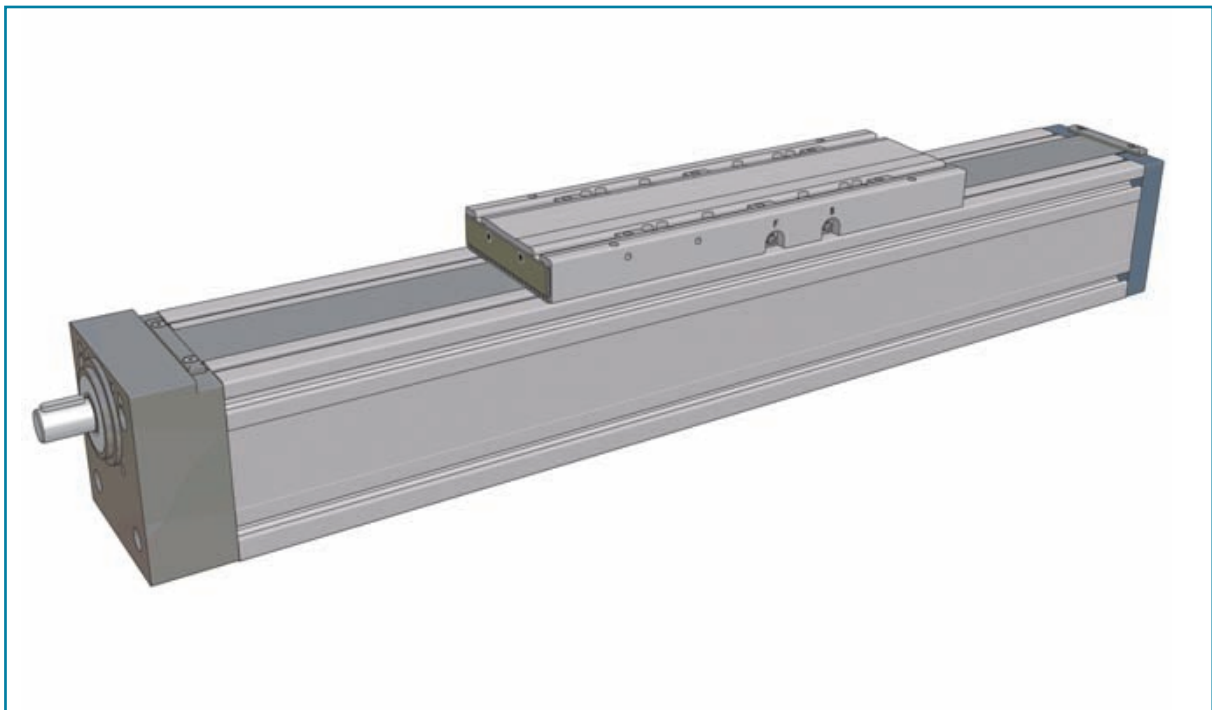
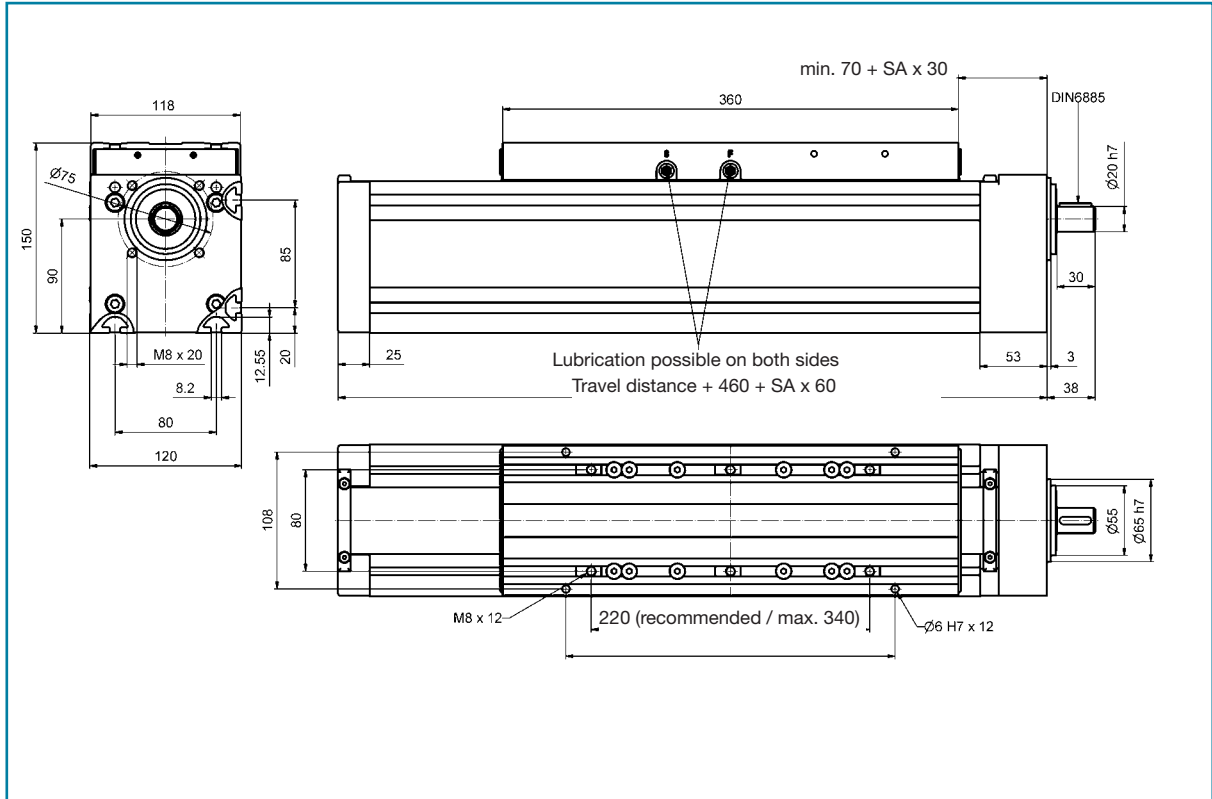

I Loads and torque loads

ID number	Roller guide		Ball rail guide	
	L	B	L	B
Table length [mm]	380		380	
Loads [N]	dyn.	stat.	dyn.	stat.
Fy	3.400	3.400	11.000	26.500
Fz	2.300	2.300	11.000	26.500
-Fz	2.300	2.300	11.000	26.500
Torque loads [Nm]	dyn.	stat.	dyn.	stat.
Mx	76	76	150	365
My	260	260	950	2.350
Mz	390	390	950	2.350

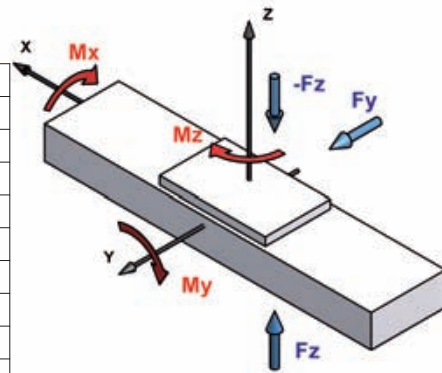

The dynamic load-bearing capacities of the guidance system are based on a nominal service life of 27,000 km.

I Technical specifications

Drive element	S3205	S3210	S3220	S3232	T3606	T3612
Pitch	5RH/LH	10RH	20RH	32RH	6RH/LH	12RH
Max. traverse rate [m/min]	23	47	94	150	3,5	6,9
Pitch accuracy [μ /300mm]	52				50	200
Dynamic load ratings screw-type drive [N]	21.600	25.900 31.700*	19.700	19.500	-	
Inertia [kgcm ² /m]	6,05	6,40	6,39	6,17	9,0	9,0
Idling speed torque [Nm]	1,0-1,3					
Geometrical moment of inertia Iy (profile) [cm ⁴]	661,10					
Geometrical moment of inertia Iz (profile) [cm ⁴]	938,57					
Maximal total length [m]	4,5 ¹⁾				5,5	
Profile bearing length ratio (nuts), [mm ²]	-				2.140	
Efficiency	0,91	0,97	0,98	0,98	0,35	0,52

* with reinforced bearing

¹⁾ Larger lengths upon request for incline 5 and 10mm.

ID number	Roller guide	Ball rail guide
	L	B
Base mass [kg]	20,0	20,5
Mass per 100 mm of travel distance [kg]	2,0	2,4
Carriage mass [kg]	6,7	7,2

I Critical rotational speed for ball screws

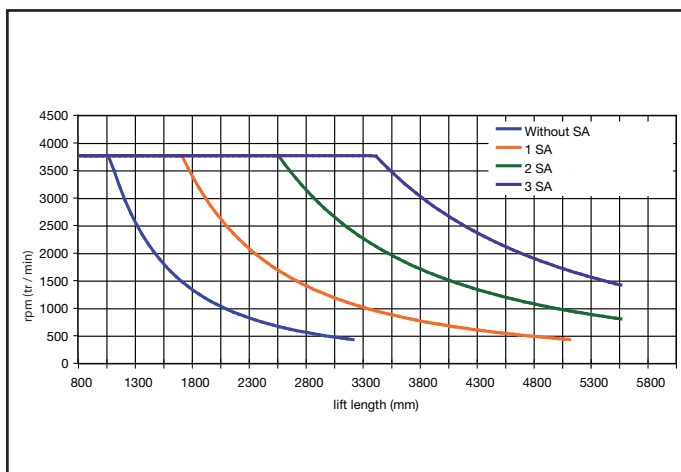

SA = set of spindle supports

Subject to technical modifications.

AXDL110Z parallel module

with synchronous belt drive and profile rail
or roller guide

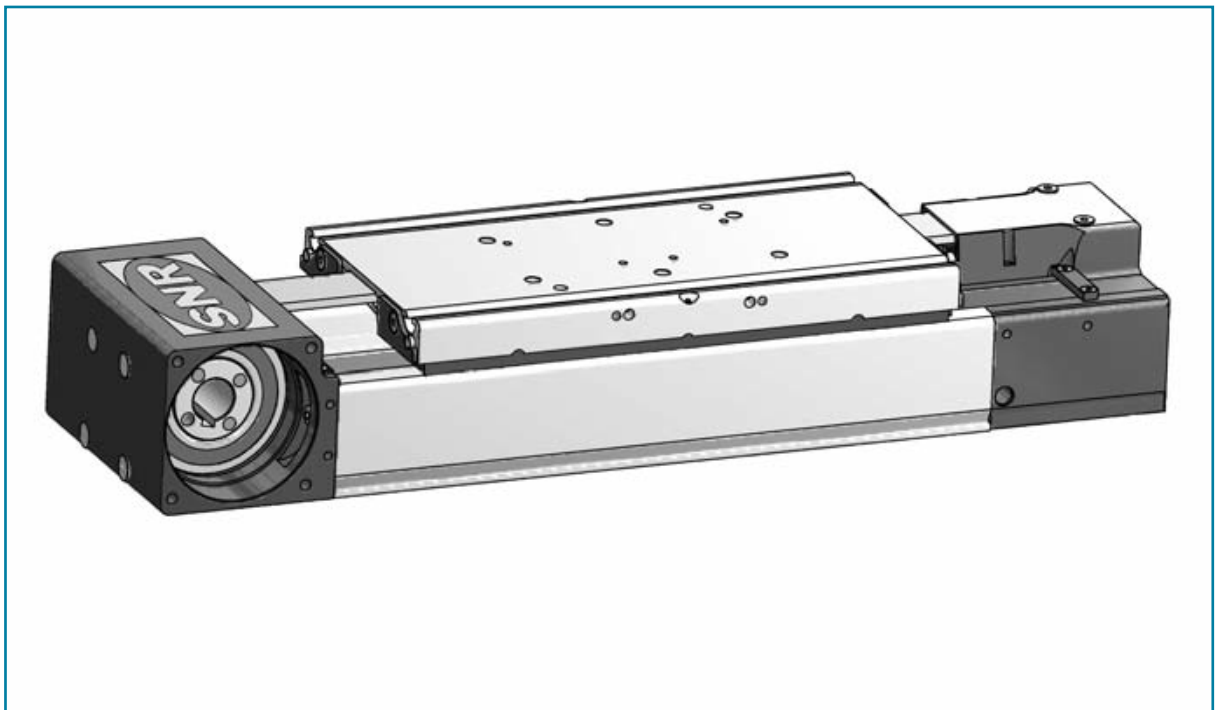
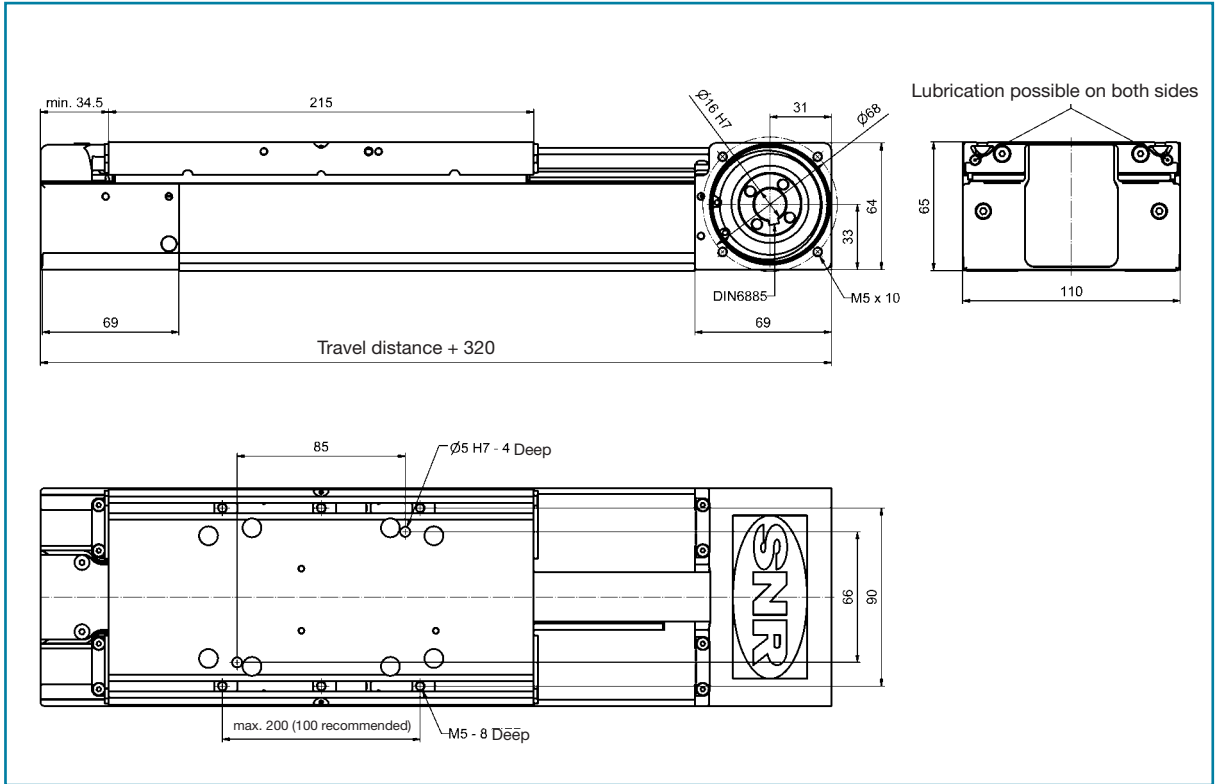

I Loads and torque loads

	Roller guide		Ball rail guide	
ID number	L		B	
Table length [mm]	215		215	
Loads [N]	dyn.	stat.	dyn.	stat.
Fy	230	230	2.200	7.700
Fz	220	230	2.200	7.700
-Fz	220	230	2.200	7.700
Torque loads [Nm]	dyn.	stat.	dyn.	stat.
Mx	8	8	75	260
My	11	12	100	365
Mz	11	12	100	365

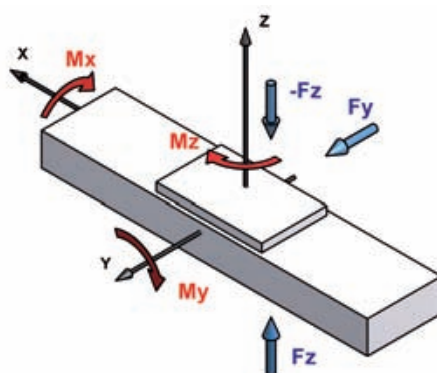

The dynamic load-bearing capacities of the guidance system are based on a nominal service life of 54.000 km.

I Technical specifications

Max. traverse rate [m/min]	600 (roller guide)
Drive element	Synchronous belt 25STD5
Allowable. dyn. working load [N]	980
Lift per revolution [mm]	175
Idling speed torque [Nm]	1,7
Inertia [kgcm ²]	1,4
Geometrical moment of inertia Iy [cm ⁴]	37,45
Geometrical moment of inertia Iz [cm ⁴]	138,31
Maximal total length [m]	6,1

	Roller guide	Ball rail guide
ID number	L	B
Base mass [kg]	3,8	3,8
Mass per 100 mm of travel distance [kg]	0,5	0,7
Carriage mass [kg]	1,1	0,9

Subject to technical modifications.

AXDL110S parallel module

with screw-type drive and profile rail
or roller guide

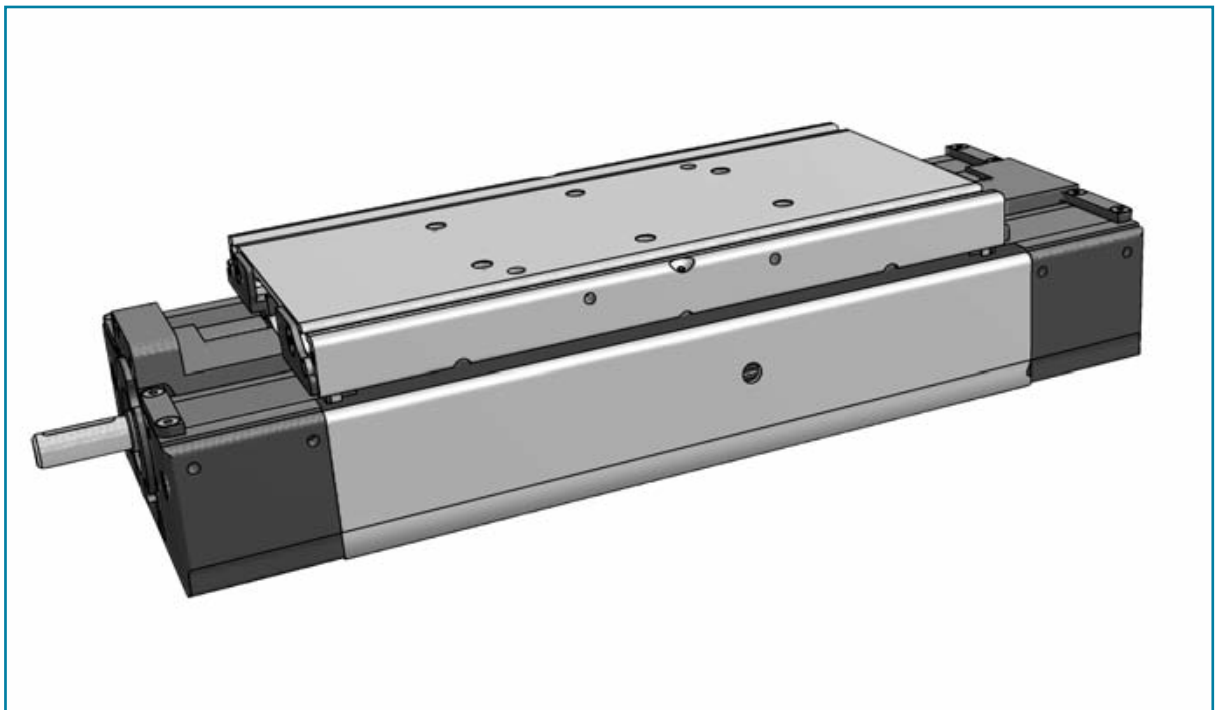
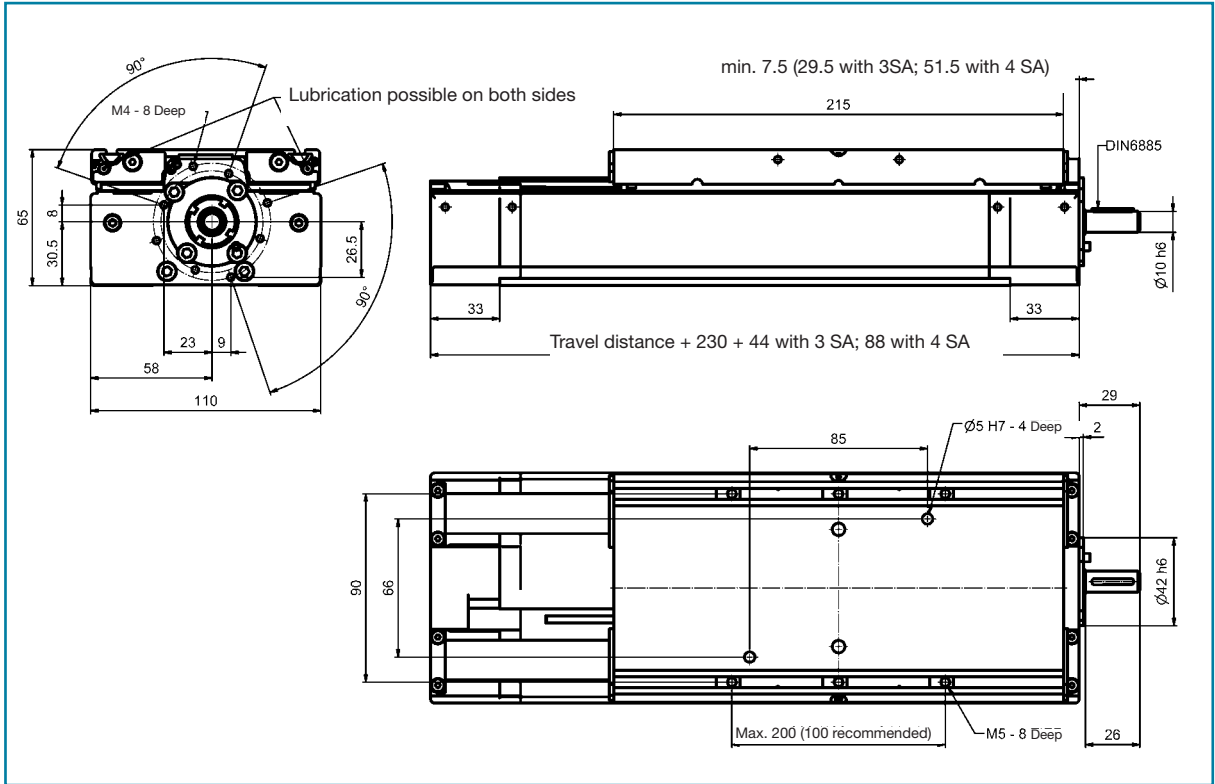

I Loads and torque loads

Ball rail guide		
ID number	B	
Table length [mm]	215	
Loads [N]	dyn.	stat.
Fy	2.800	7.700
Fz	2.800	7.700
-Fz	2.800	7.700
Torque loads [Nm]	dyn.	stat.
Mx	95	260
My	130	365
Mz	130	365

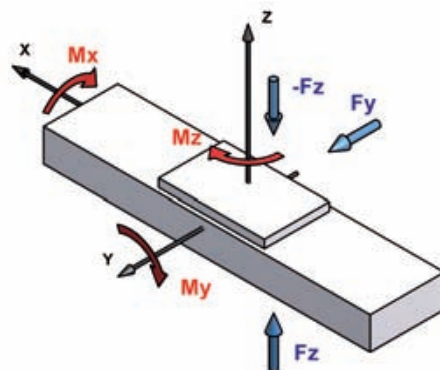

The dynamic load-bearing capacities of the guidance system are based on a nominal service life of 27,000 km.

I Technical specifications

Drive element	S1605	S1610	S1616	T1604	T1608
Pitch	5RH/LH	10RH	16RH	4RH/LH	8RH
Max, traverse rate [m/min]	30	60	96	5,5	10,9
Pitch accuracy [μ /300mm]	52			50	100
Dynamic load ratings screw-type drive [N]	12.300	9.600	6.300	-	
Inertia [kgcm^2/m]	0,31	0,31	0,34	0,3	0,3
Idling speed torque [Nm]	0,8				
Geometrical moment of inertia ly (profile) [cm^4]	37,45				
Geometrical moment of inertia lz (profile) [cm^4]	138,3				
Maximal total length [m]	4,5 ¹⁾			5,5	
Profile bearing length ratio (nuts), [mm ²]	-			2140	
Efficiency	0,91	0,97	0,98	0,35	0,52

1) Greater lengths upon request.

Ball rail guide	
ID number	B
Base mass [kg]	4,2
Mass per 100 mm of travel distance [kg]	0,7
Carriage mass [kg]	1,4

I Critical rotational speed for ball screws

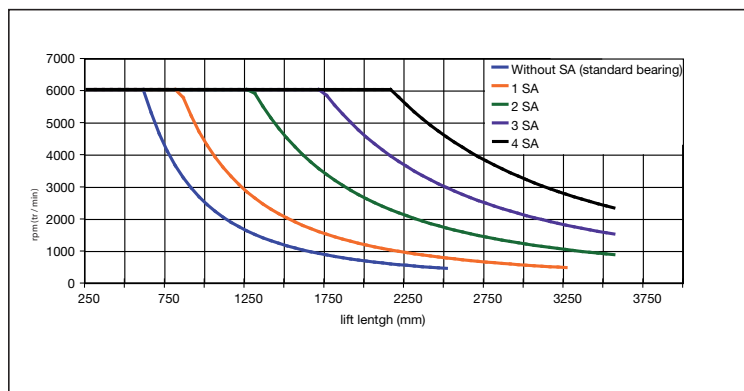

SA = set of spindle support

Subject to technical modifications.

AXDL160Z parallel module

with synchronous belt drive and rail system
or roller guide

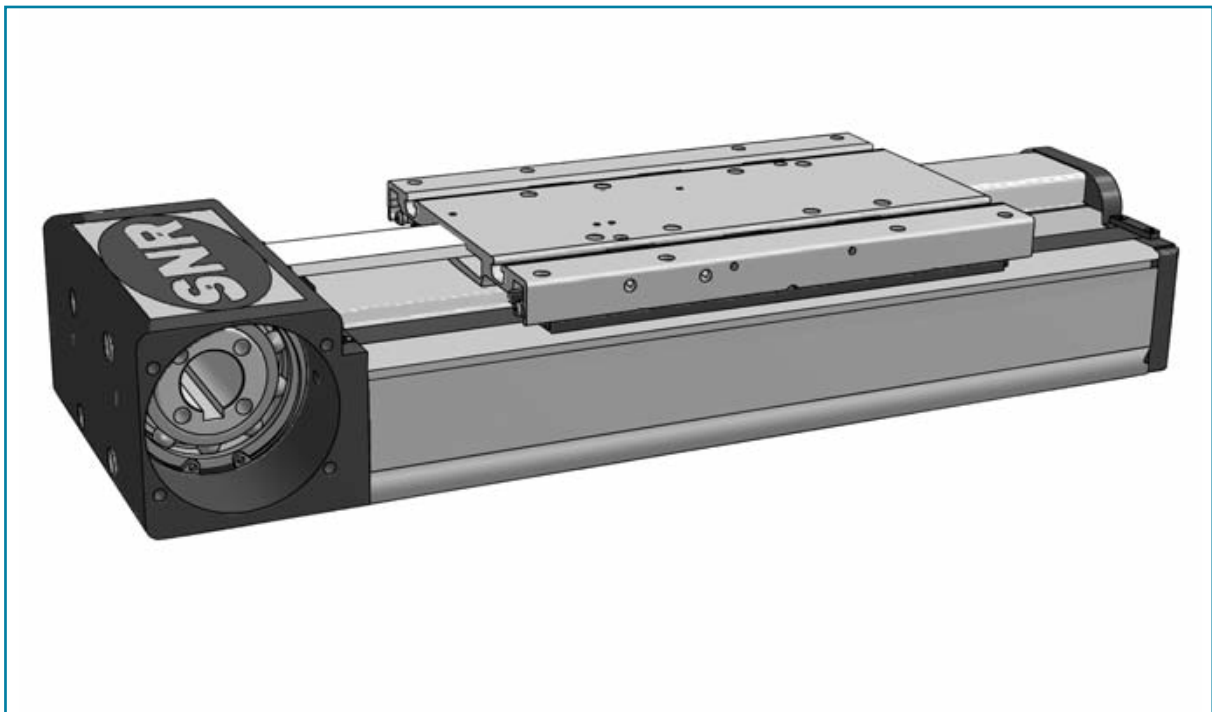
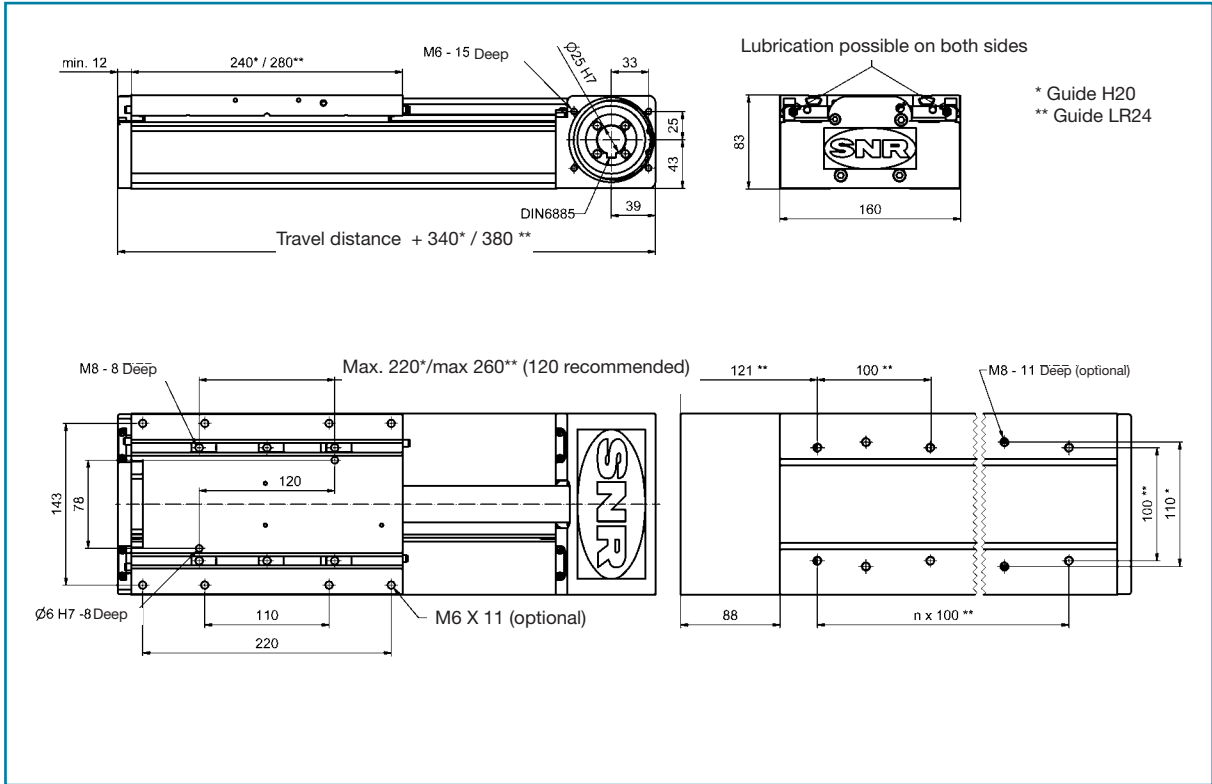

I Loads and torque loads

	Roller guide		Ball rail guide	
ID number	L		B	
Table length [mm]	280		240	
Loads [N]	dyn.	stat.	dyn.	stat.
Fy	1.200	1.200	8.700	30.000
Fz	1.200	1.200	8.700	30.000
-Fz	1.200	1.200	8.700	30.000
Torque loads [Nm]	dyn.	stat.	dyn.	stat.
Mx	62	62	430	1.500
My	84	84	430	1.500
Mz	84	84	430	1.500

The dynamic load-bearing capacities of the guidance system are based on a nominal service life of 54,000 km.

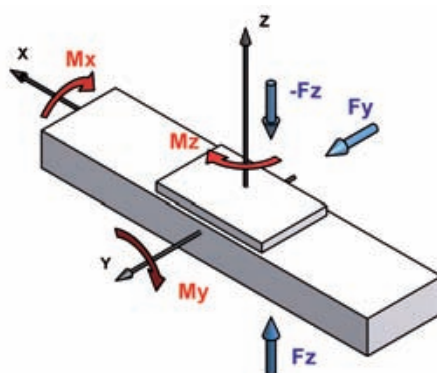

I Technical specifications

Max. traverse rate [m/min]	600 (roller guide)
Drive element	Synchronous belt 32STD8
Allowable. dyn. working load [N]	1.830
Lift per revolution [mm]	224
Idling speed torque [Nm]	3,6
Inertia [kgcm ²]	5,8
Geometrical moment of inertia Iy [cm ⁴]	140,29
Geometrical moment of inertia Iz [cm ⁴]	666,8
Maximal total length [m]	6,1

	Roller guide	Ball rail guide
ID number	L	B
Base mass [kg]	11,7	11,9
Mass per 100 mm of travel distance [kg]	0,9	1,3
Carriage mass [kg]	3,6	3,6

Subject to technical modifications.

AXDL160S parallel module

with screw-type drive and profile ball ball rail guide

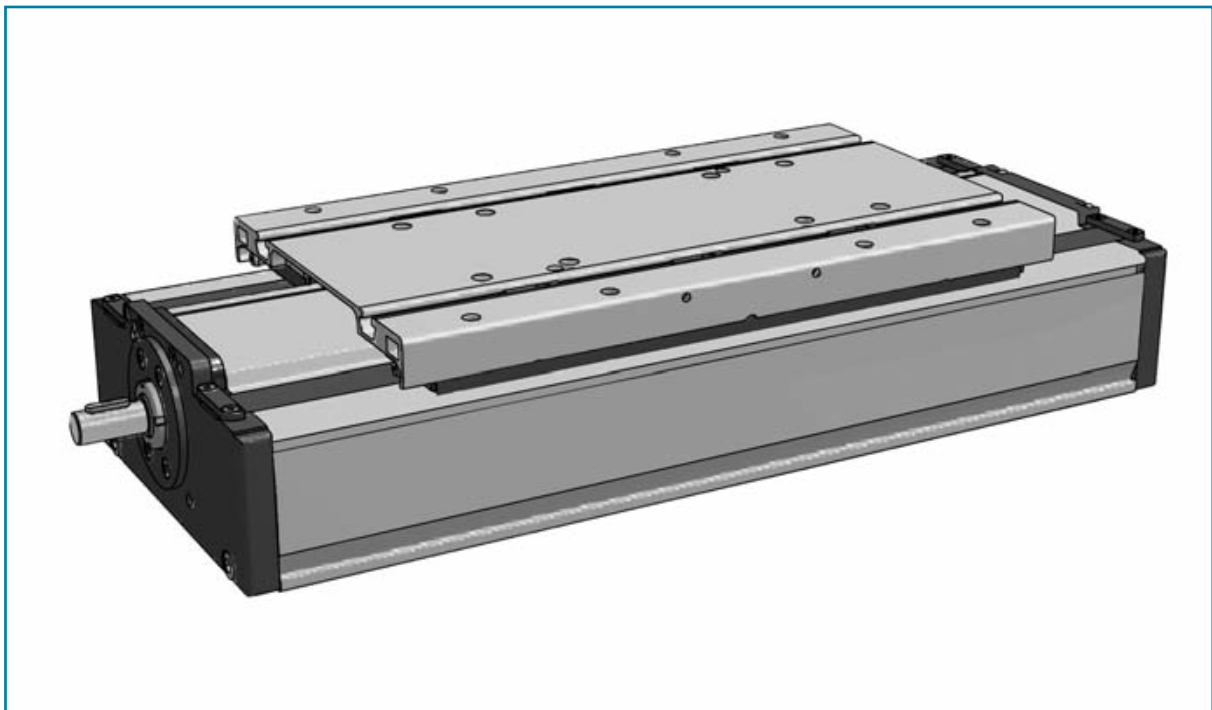
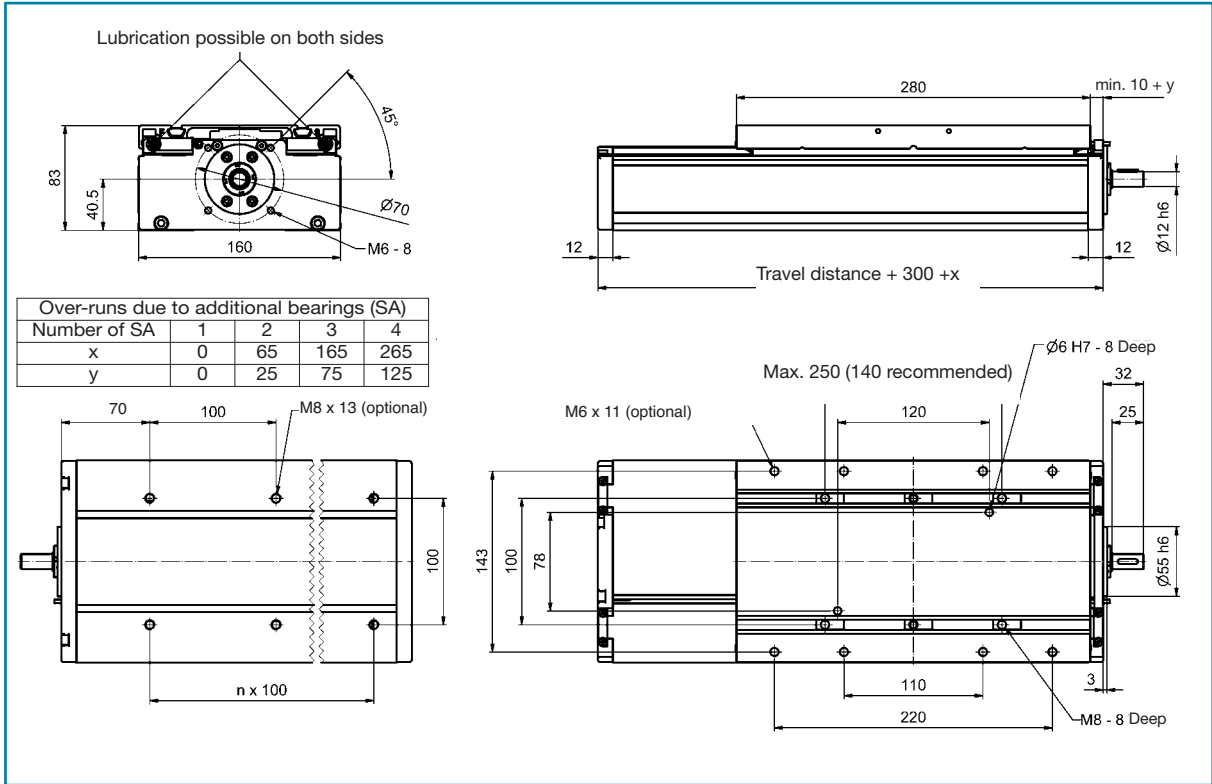

I Loads and torque loads

Ball rail guide		
ID number	B	
Table length [mm]	280	
Loads [N]	dyn.	stat.
Fy	10.900	30.000
Fz	10.900	30.000
-Fz	10.900	30.000
Torque loads [Nm]	dyn.	stat.
Mx	540	1.500
My	700	2.000
Mz	700	2.000

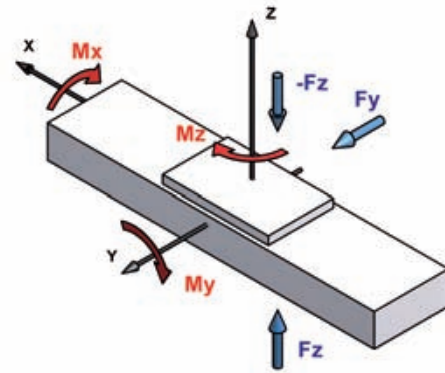

The dynamic load-bearing capacities of the guidance system are based on a nominal service life of 27,000 km.

I Technical specifications

Drive element	S2020	S2050	S2505	S2510	T2405	T2410
Pitch	20RH	50RH	5RH	10RH	5RH/LH	10RH
Max. traverse rate [m/min]	120	150	30	60	4,4	8,9
Pitch accuracy [μ /300mm]	52				50	200
Dynamic load ratings screw-type drive [N]	9.100	13.000	15.900	15.700	-	
Inertia [kgcm ² /m]	0,81	0,79	2,22	2,39	1,5	1,5
Idling speed torque [Nm]	0,6-1,0					
Geometrical moment of inertia Iy (profile) [cm ⁴]	140,29					
Geometrical moment of inertia Iz (profile) [cm ⁴]	666,8					
Maximal total length [m]	3,5	5,5	3,5			
Profile bearing length ratio (nuts), [mm ²]	-				1040	
Efficiency	0,98	0,98	0,93	0,98	0,41	0,58

Ball rail guide	
ID number	B
Base mass [kg]	9,7
Mass per 100 mm of travel distance [kg]	1,4
Carriage mass [kg]	4,2

I Critical rotational speed for ball screws

• Ball screw diameter 20 mm

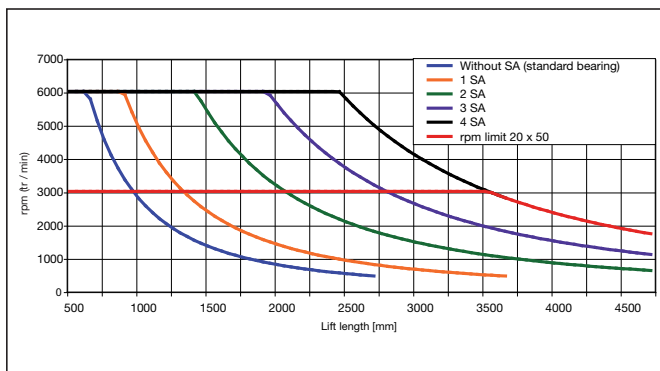

• Ball screw diameter 25 mm

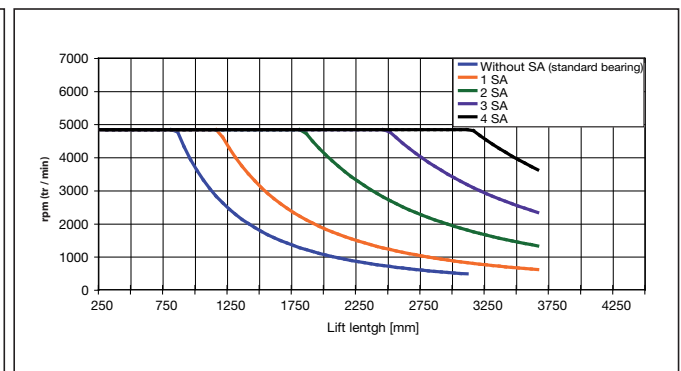

Subject to technical modifications.

AXDL240Z parallel module

with synchronous belt drive and profile rail
or roller guide

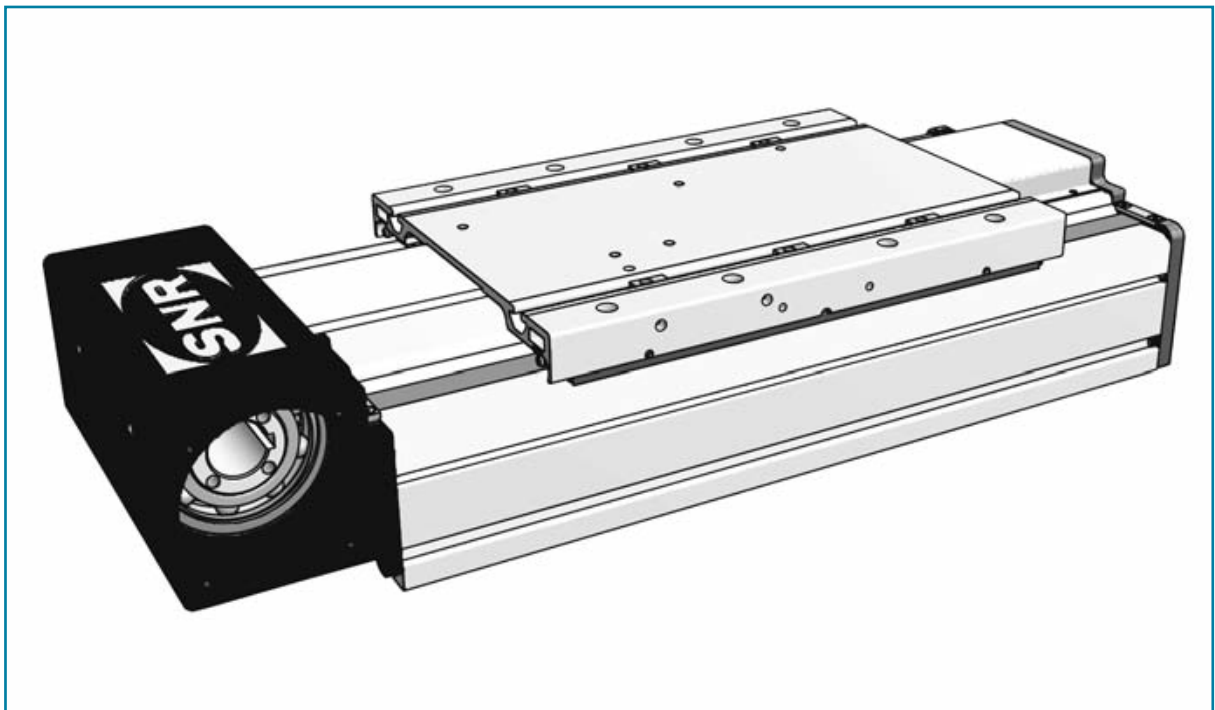
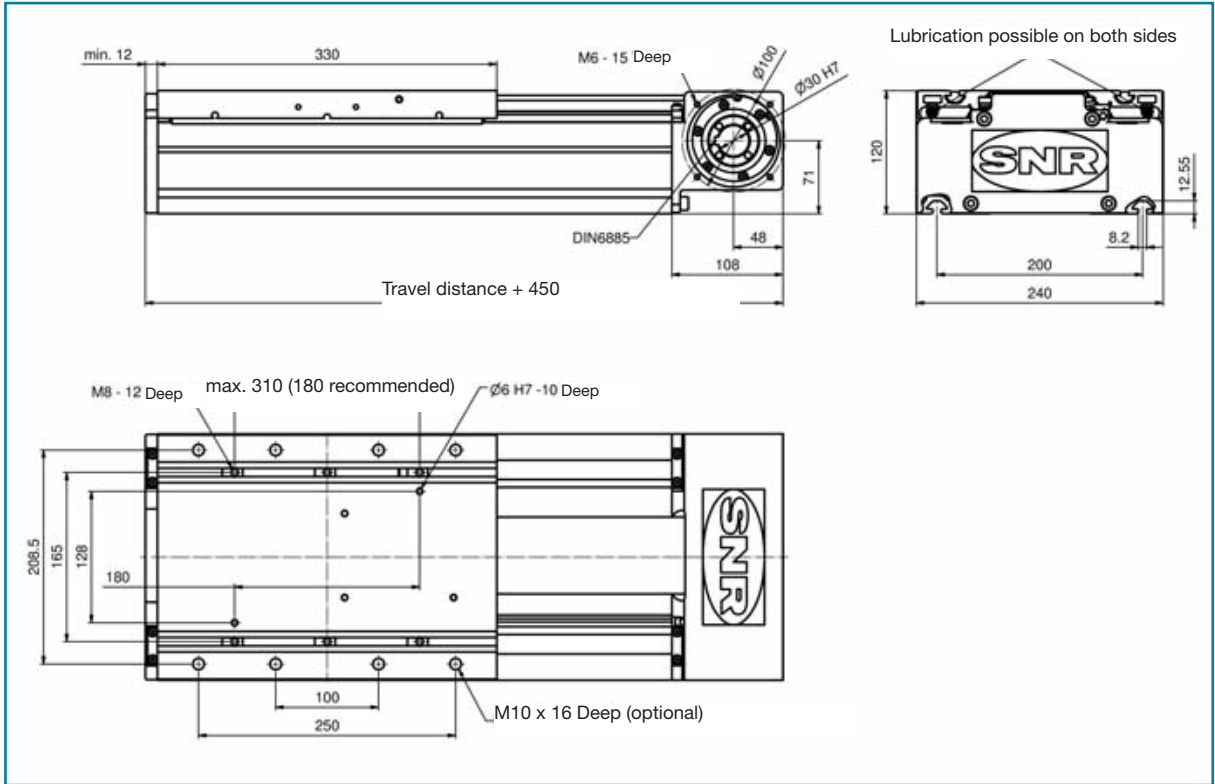

I Loads and torque loads

	Roller guide		Ball rail guide	
ID number	L		B	
Table length [mm]	330		330	
Loads [N]	dyn.	stat.	dyn.	stat.
Fy	2.600	2.600	12.300	42.000
Fz	2.600	2.600	12.300	42.000
-Fz	2.600	2.600	12.300	42.000
Torque loads [Nm]	dyn.	stat.	dyn.	stat.
Mx	220	220	950	3.200
My	210	210	1.050	3.550
Mz	210	210	1.050	3.550

The dynamic load-bearing capacities of the guidance system are based on a nominal service life of 54,000 km.

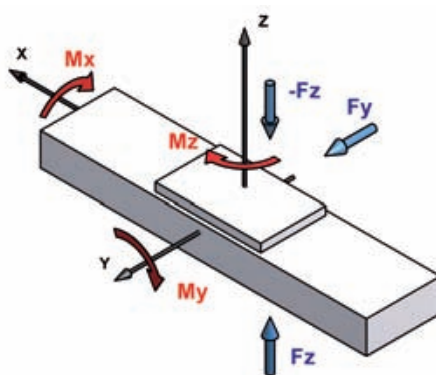

I Technical specifications

Max. traverse rate [m/min]	600 (roller guide)
Drive element	Synchronous belt 75STD8
Allowable. dyn. working load [N]	5.000
Lift per revolution [mm]	272
Idling speed torque [Nm]	6,5
Inertia [kgcm ²]	24,3
Geometrical moment of inertia Iy [cm ⁴]	751,7
Geometrical moment of inertia Iz [cm ⁴]	3956,0
Maximal total length [m]	6,35

	Roller guide	Ball rail guide
ID number	L	B
Base mass [kg]	24,3	24,9
Mass per 100 mm of travel distance [kg]	2,2	2,7
Carriage mass [kg]	6,6	5,7

Subject to technical modifications.

AXDL240S parallel module

with screw-type drive and profile ball ball rail guide

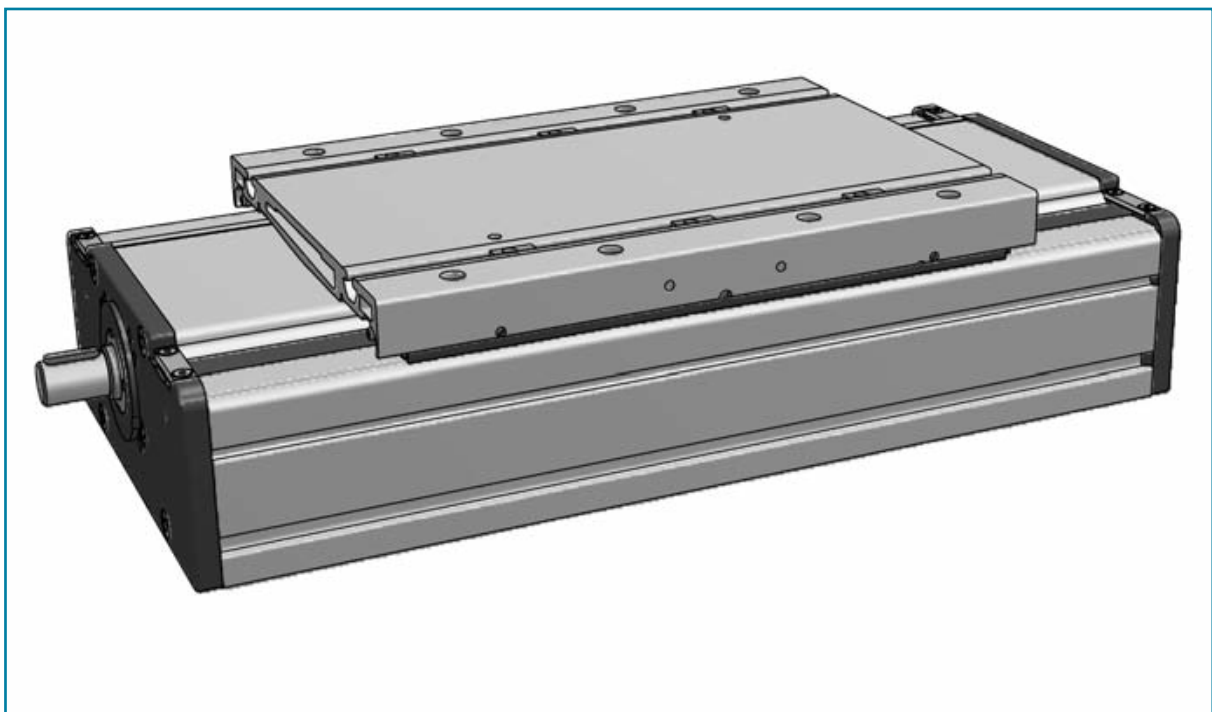
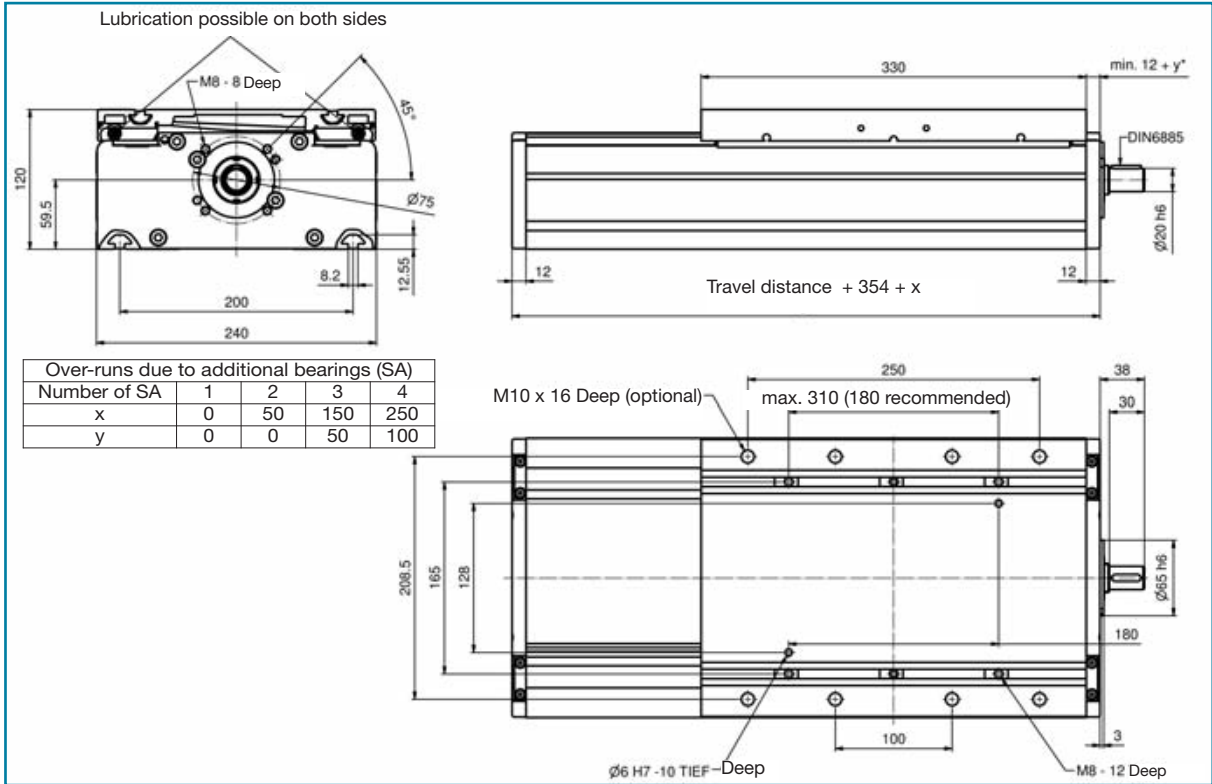

I Loads and torque loads

Ball rail guide		
ID number	B	
Table length [mm]	330	
Loads [N]	dyn.	stat.
Fy	15.500	42.000
Fz	15.500	42.000
-Fz	15.500	42.000
Torque loads [Nm]	dyn.	stat.
Mx	1.200	3.200
My	1.300	3.550
Mz	1.300	3.550

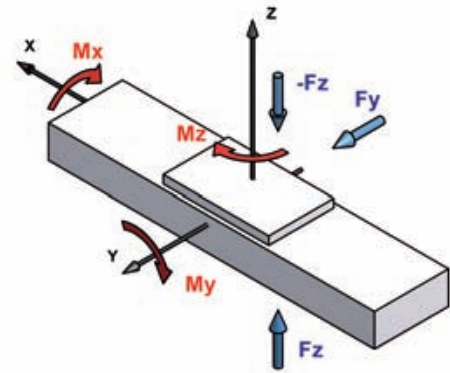

The dynamic load-bearing capacities of the guidance system are based on a nominal service life of 27,000 km.

I Technical specifications

Drive element	S3205	S3210	S3220	S3232	T3606	T3612
Pitch	5RH/LH	10RH	20RH	32RH	6RH/LH	12RH
Max. traverse rate [m/min]	23	47	94	150	3,5	6,9
Pitch accuracy [μ /300mm]	52				50	200
Dynamic load ratings screw-type drive [N]	21.600	31.700	19.700	19.500	-	
Inertia [kgcm ² /m]	6,05	6,40	6,39	6,17	9,0	9,0
Idling speed torque [Nm]	1,5-2,0					
Geometrical moment of inertia Iy (profile) [cm ⁴]	751,7					
Geometrical moment of inertia Iz (profile) [cm ⁴]	3956,0					
Maximal total length [m]	4,5					
Profile bearing length ratio (nuts), [mm ²]	-				2140	
Efficiency	0,91	0,97	0,98	0,98	0,35	0,52

1) Larger lengths upon request for incline 5 and 10mm.

Ball rail guide	
ID number	B
Base mass [kg]	22,1
Mass per 100 mm of travel distance [kg]	3,1
Carriage mass [kg]	6,4

I Critical rotational speed for ball screws

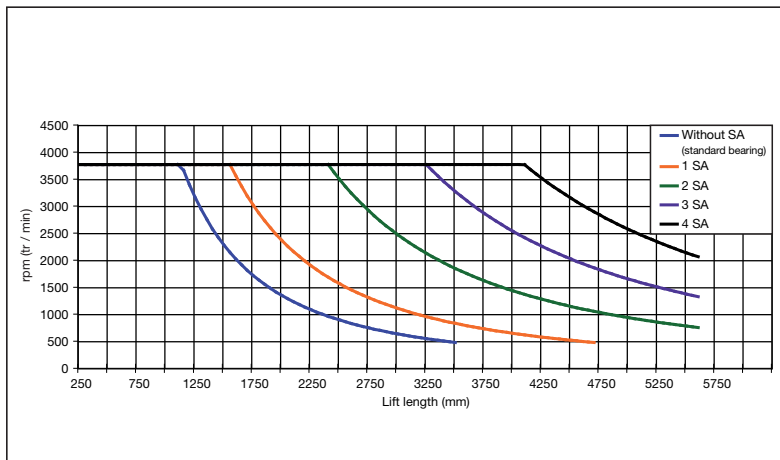

SA = set of spindle support

Subject to technical modifications.

AXLT155 linear table with screw-type drive and profile ball ball rail guide

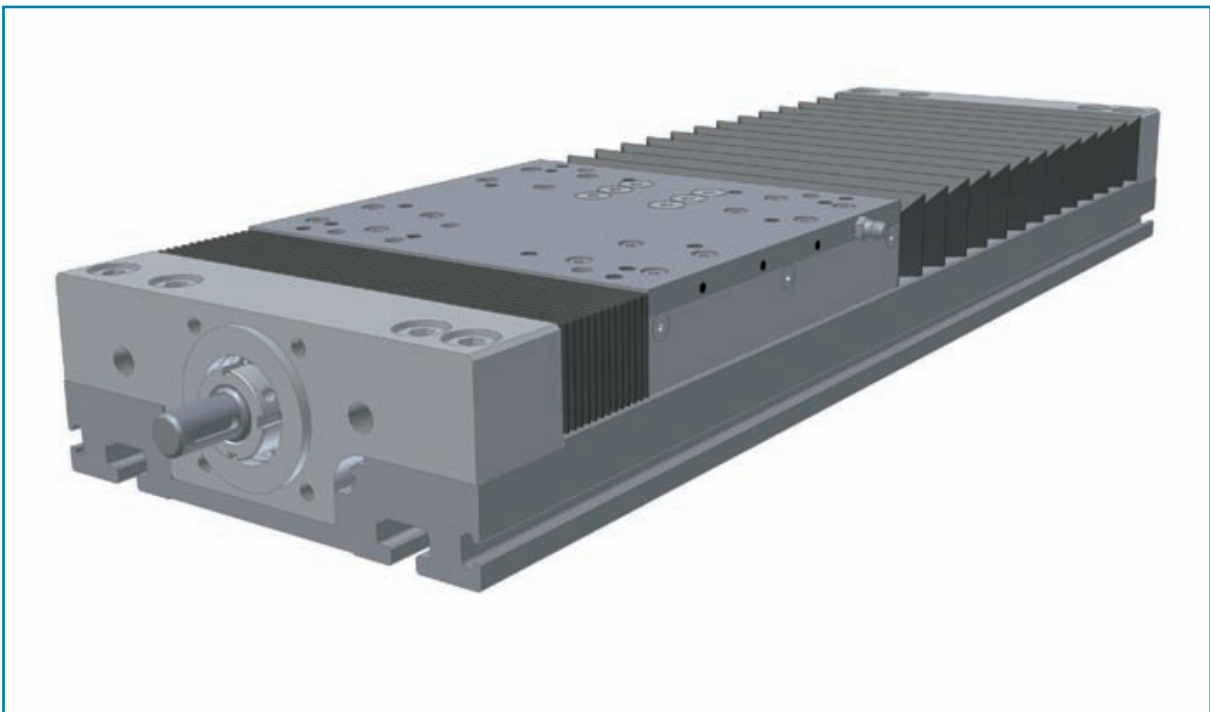
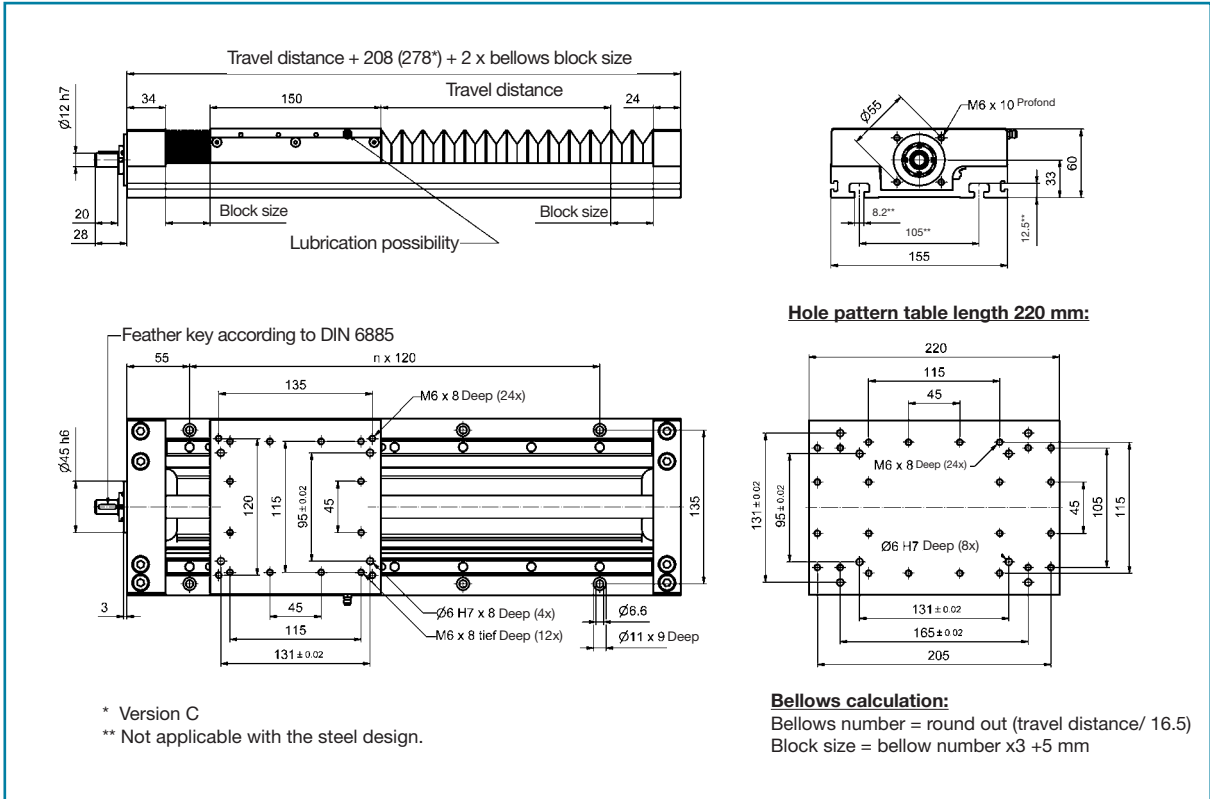

I Loads and torque loads

ID number	Ball rail guide			
	B		C	
Table length [mm]	150		220	
Loads [N]	dyn.	stat.	dyn.	stat.
Fy	6.900	19.000	6.900	19.000
Fz	6.900	19.000	6.900	19.000
-Fz	6.900	19.000	6.900	19.000
Torque loads [Nm]	dyn.	stat.	dyn.	stat.
Mx	340	950	340	950
My	280	790	420	1.100
Mz	280	790	420	1.100

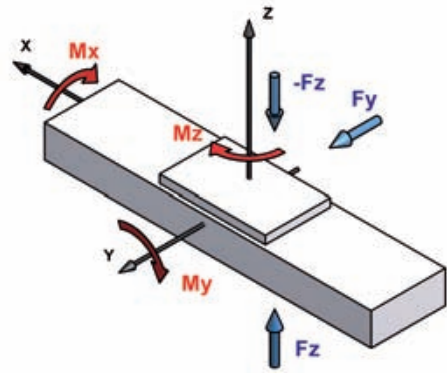

The dynamic load-bearing capacities of the guidance system are based on a nominal service life of 27,000 km.

I Technical specifications

Drive element	S2005	S2020	T2004	T2008
Pitch	5RH/LH	20RH	4RH/LH	8RH
Max. traverse rate [m/min]	30	120	4,2	8,5
Pitch accuracy [μ /300mm]	52		50	100
Dynamic load ratings screw-type drive [N]	17.500	13.300	-	
Inertia [kgcm ² /m]	0,84	0,81	0,81	0,81
Idling speed torque [Nm]	0,6-0,8			
Maximal total length [m]	3,5			
Profile bearing length ratio (nuts), [mm ²]	-		870	
Efficiency	0,95	0,98	0,40	0,57

ID number	Ball rail guide	
	B	C
Base mass [kg]	5,5	6,2
Mass per 100 mm of travel distance [kg]	1,2	1,2
Carriage mass [kg]	2,0	2,3

I Critical rotational speed for ball screws

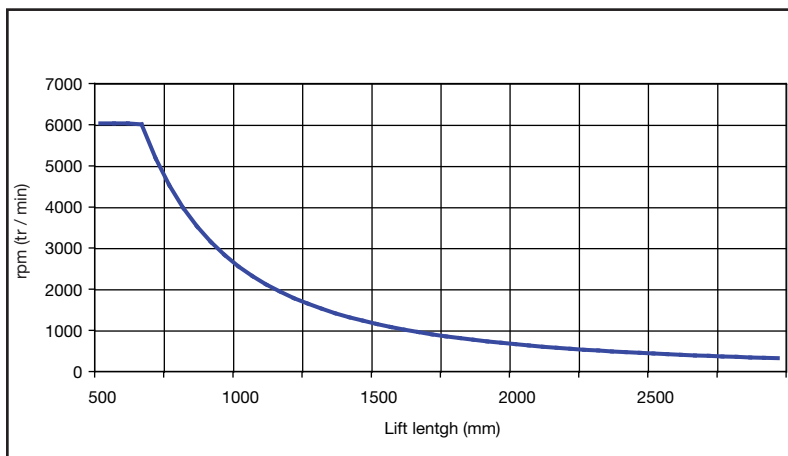

Subject to technical modifications.

AXLT225 linear table

with screw-type drive and profile ball rail guide

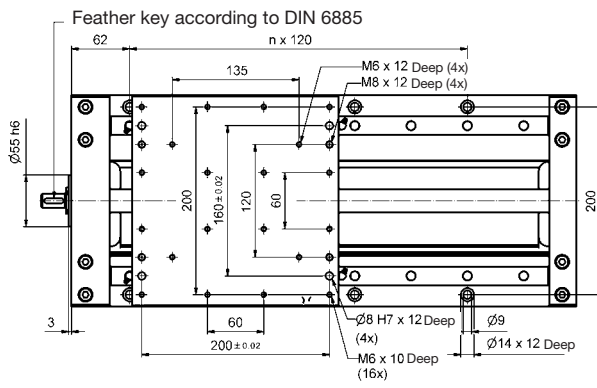
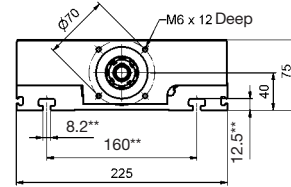
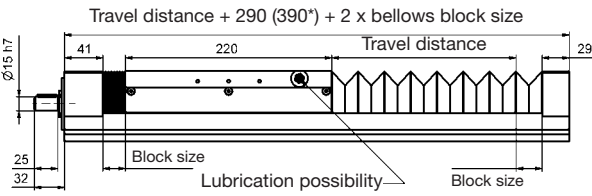

Hole pattern for table length 320 mm:

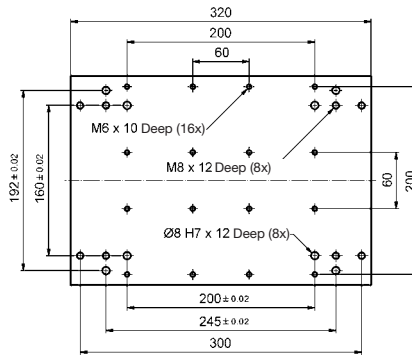

Bellows calculation:

Bellows number = round out (travel distance / 27)
 Block size = bellows number x 3 + 5 mm

* Version C

** Not applicable with the steel design.

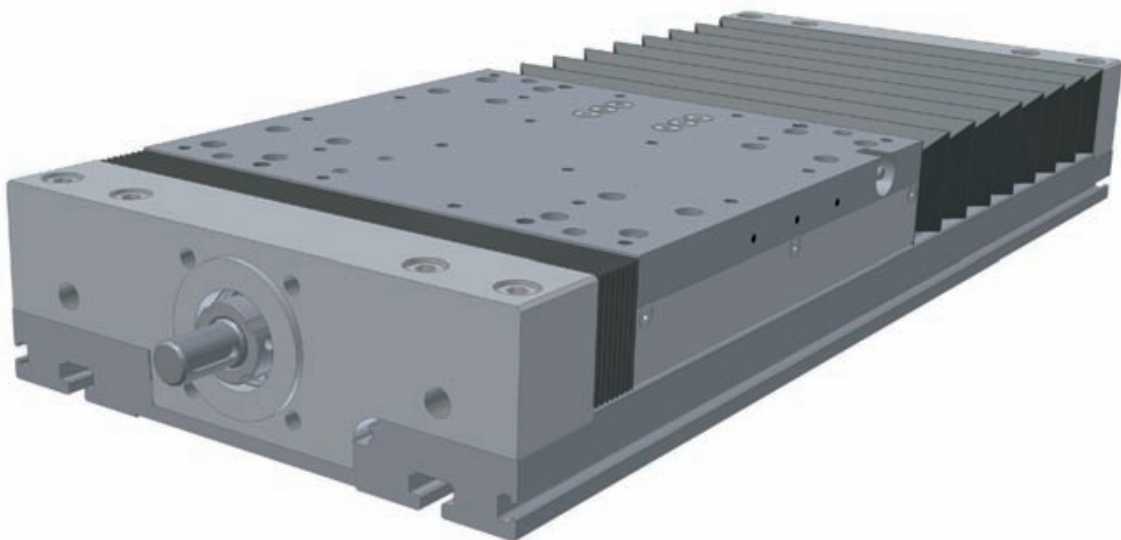

I Loads and torque loads

ID number	Ball rail guide			
	B		C	
Table length [mm]	220		320	
Loads [N]	dyn.	stat.	dyn.	stat.
Fy	10.900	30.000	10.900	30.000
Fz	10.900	30.000	10.900	30.000
-Fz	10.900	30.000	10.900	30.000
Torque loads [Nm]	dyn.	stat.	dyn.	stat.
Mx	810	2.250	810	2.250
My	720	2.000	930	2.600
Mz	720	2.000	930	2.600

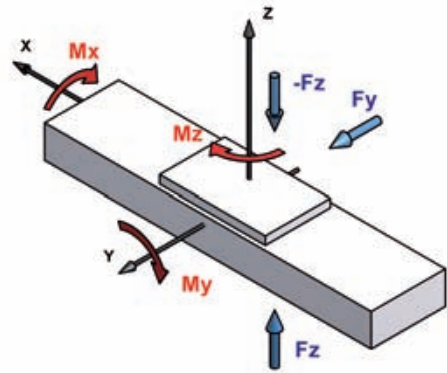

The dynamic load-bearing capacities of the guidance system are based on a nominal service life of 27,000 km.

I Technical specifications

Drive element	S2505	S2510	S2525	T2405	T2410
Pitch	5RH	10RH	25RH	5RH/LH	10RH
Max. traverse rate [m/min]	30	60	150	4,4	8,9
Pitch accuracy [μ /300mm]	52			50	200
Dynamic load ratings screw-type drive [N]	15.900	15.700	14.700	-	
Inertia [kgcm ² /m]	2,22	2,39	2,15	1,5	1,5
Idling speed torque [Nm]	0,7-1,2				
Maximal total length [m]	3,5				
Profile bearing length ratio (nuts), [mm ²]	-			1040	
Efficiency	0,93	0,98	0,98	0,41	0,58

ID number	Ball rail guide	
	B	C
Base mass [kg]	13,0	15,8
Mass per 100 mm of travel distance [kg]	1,8	1,8
Carriage mass [kg]	5,0	6,0

I Critical rotational speed for ball screws

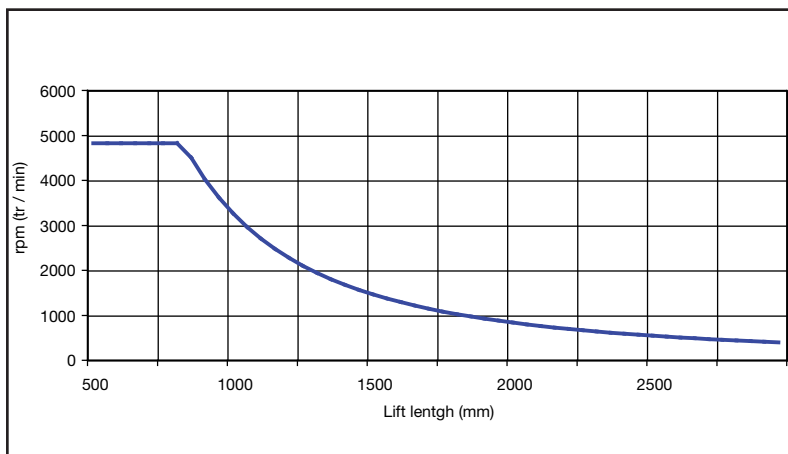

Subject to technical modifications.

AXLT325 linear table

with screw-type drive and profile ball rail guide

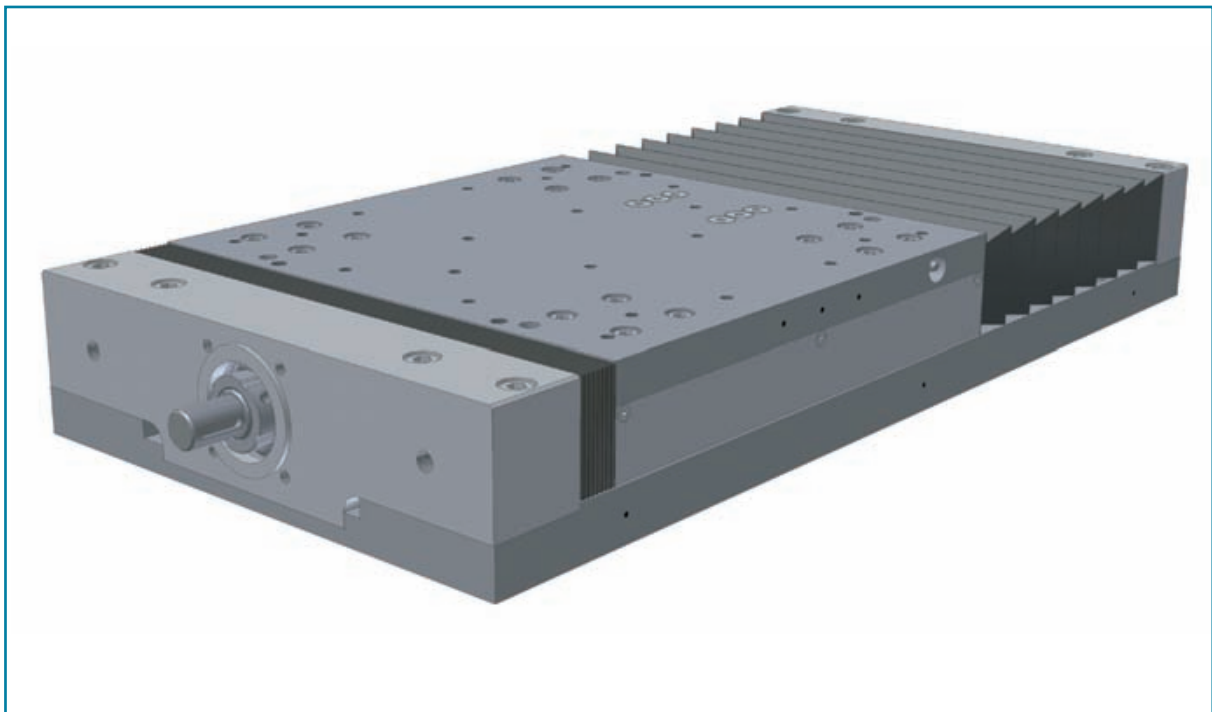
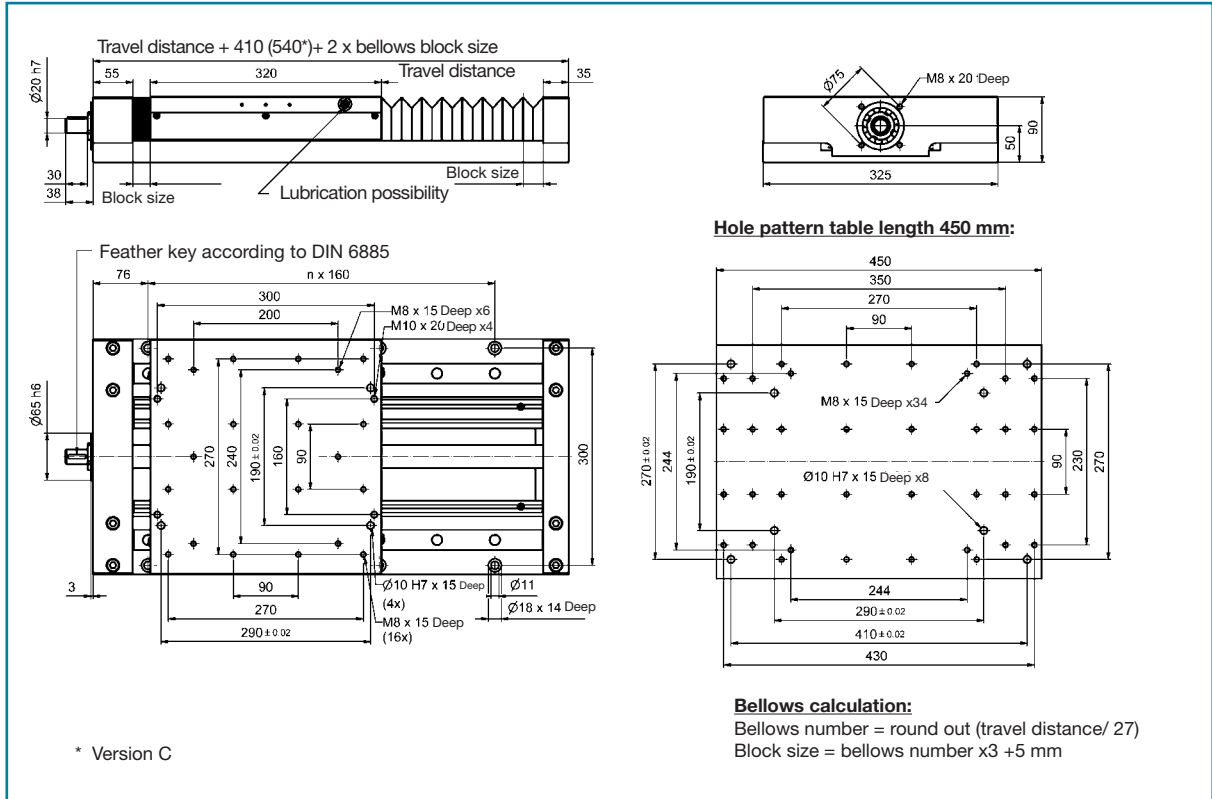

I Loads and torque loads

ID number	Ball rail guide			
	B		C	
Table length [mm]	320		450	
Loads [N]	dyn.	stat.	dyn.	stat.
Fy	22.000	53.000	22.000	53.000
Fz	22.000	53.000	22.000	53.000
-Fz	22.000	53.000	22.000	53.000
Torque loads [Nm]	dyn.	stat.	dyn.	stat.
Mx	2.250	5.500	2.250	5.500
My	2.000	4.900	2.700	6.500
Mz	2.000	4.900	2.700	6.500

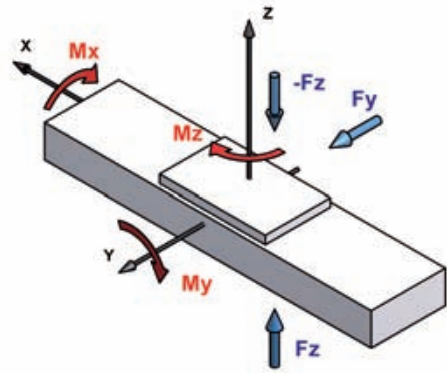

The dynamic load-bearing capacities of the guidance system are based on a nominal service life of 27,000 km.

I Technical specifications

Drive element	S3205	S3210	S3220	S3232	T3606	T3612
Pitch	5RH/LH	10RH	20RH	32RH	6RH/LH	12RH
Max. traverse rate [m/min]	23	47	94	150	3,5	6,9
Pitch accuracy [μ /300mm]	52				50	200
Dynamic load ratings screw-type drive [N]	21.600	31.700	19.700	19.500	-	
Inertia [kgcm ² /m]	6,05	6,40	6,39	6,17	9,0	9,0
Idling speed torque [Nm]	1,1-1,5					
Maximal total length [m]	3,2					
Profile bearing length ratio (nuts), [mm ²]	-				2140	
Efficiency	0,91	0,97	0,98	0,98	0,35	0,52

ID number	Ball rail guide	
	B	C
Base mass [kg]	31,5	38,7
Mass per 100 mm of travel distance [kg]	3,5	3,5
Carriage mass [kg]	12,0	14,6

I Critical rotational speed for ball screws

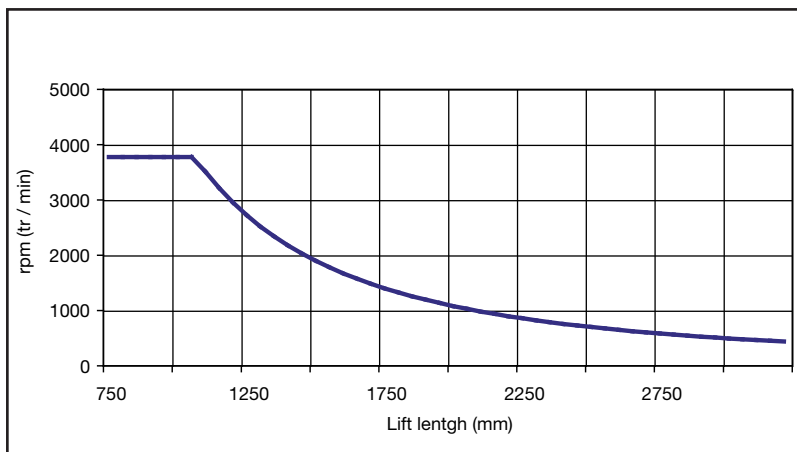

Subject to technical modifications.

AXLT455 linear table

with screw-type drives and profile rail
or roller guide

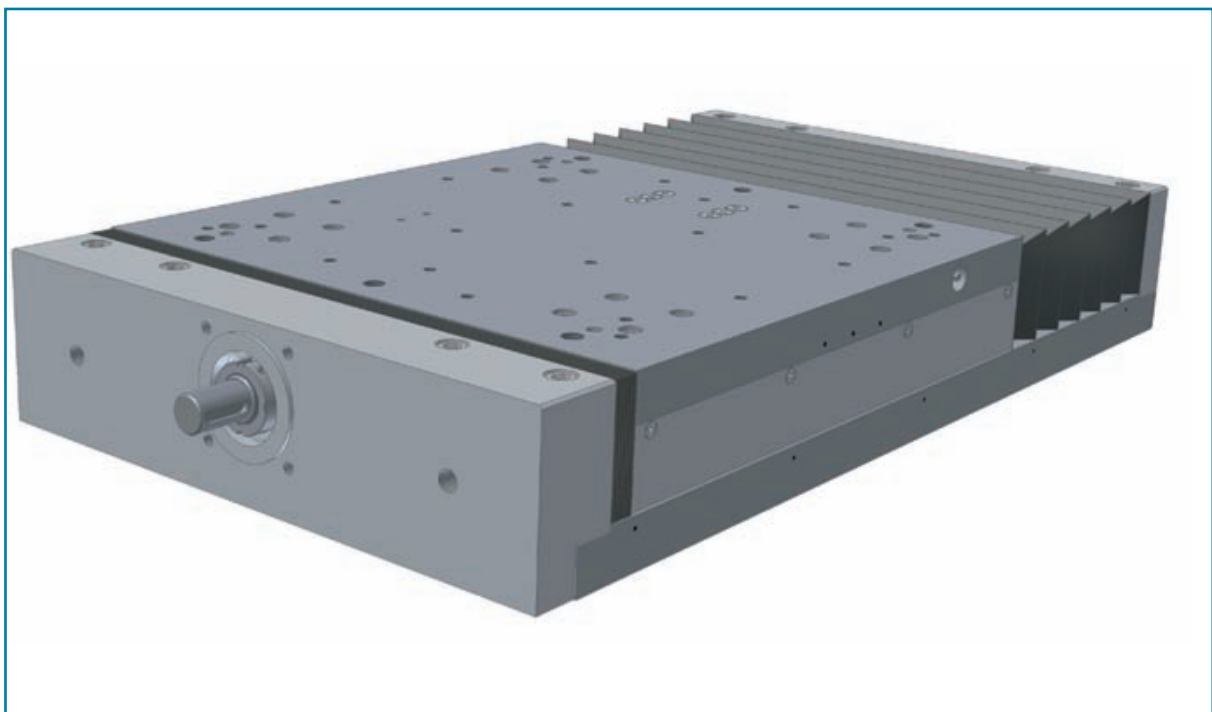
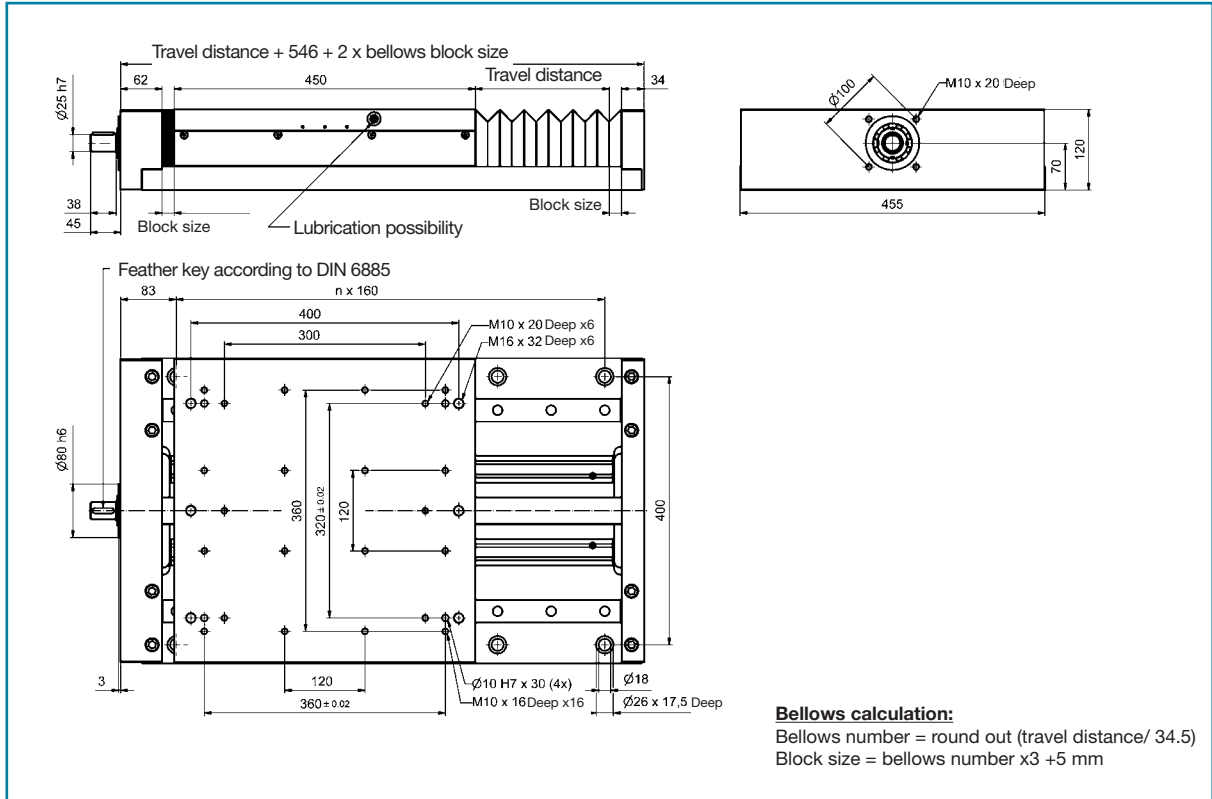

I Loads and torque loads

Ball rail guide		
ID number	B	
Table length [mm]	450	
Loads [N]	dyn.	stat.
Fy	30.000	77.000
Fz	30.000	77.000
-Fz	30.000	77.000
Torque loads [Nm]	dyn.	stat.
Mx	3.950	10.000
My	3.700	9.500
Mz	3.700	9.500

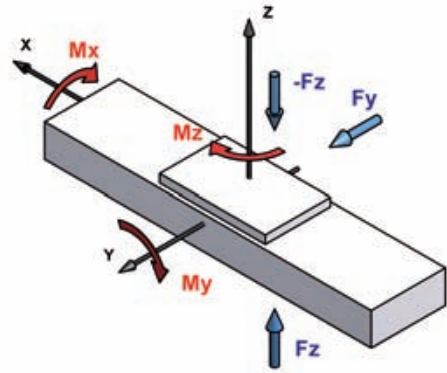

The dynamic load-bearing capacities of the guidance system are based on a nominal service life of 27,000 km.

I Technical specifications

Drive element	S4005	S4010	S4020	S4040	T4007
Pitch	5RH/LH	10RH	20RH	40RH	7RH/LH
Max. traverse rate [m/min]	19	38	75	150	3,7
Pitch accuracy [μ /300mm]	52				80
Dynamic load ratings screw-type drive [N]	29.100	50.000	37.900	37.000	-
Inertia [kgcm ² /m]	15,64	13,55	13,52	13,42	13,0
Idling speed torque [Nm]	1,7-2,8				
Maximal total length [m]	3,2				
Profile bearing length ratio (nuts), [mm ²]	-				2930
Efficiency	0,89	0,95	0,98	0,98	0,37

Ball rail guide	
ID number	B
Base mass [kg]	74,0
Mass per 100 mm of travel distance [kg]	6,3
Carriage mass [kg]	29,0

I Critical rotational speed for ball screws

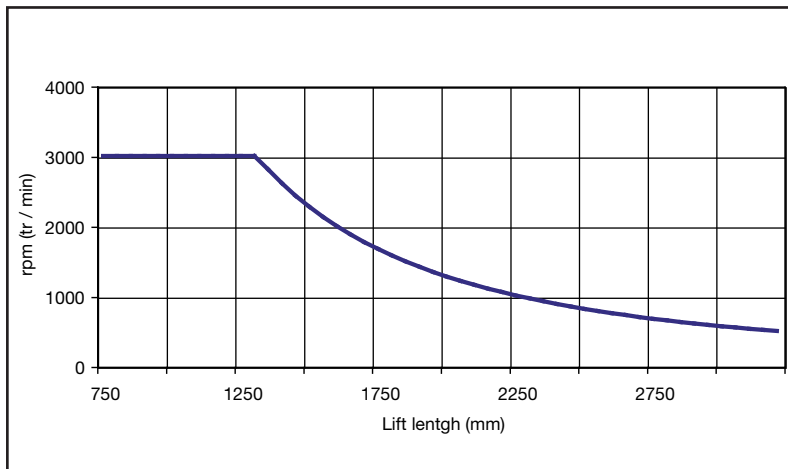

Subject to technical modifications.

AXS120TM telescopic axis

with combined drive consisting of synchronous belt and rack and pinion (profile ball rail guide)

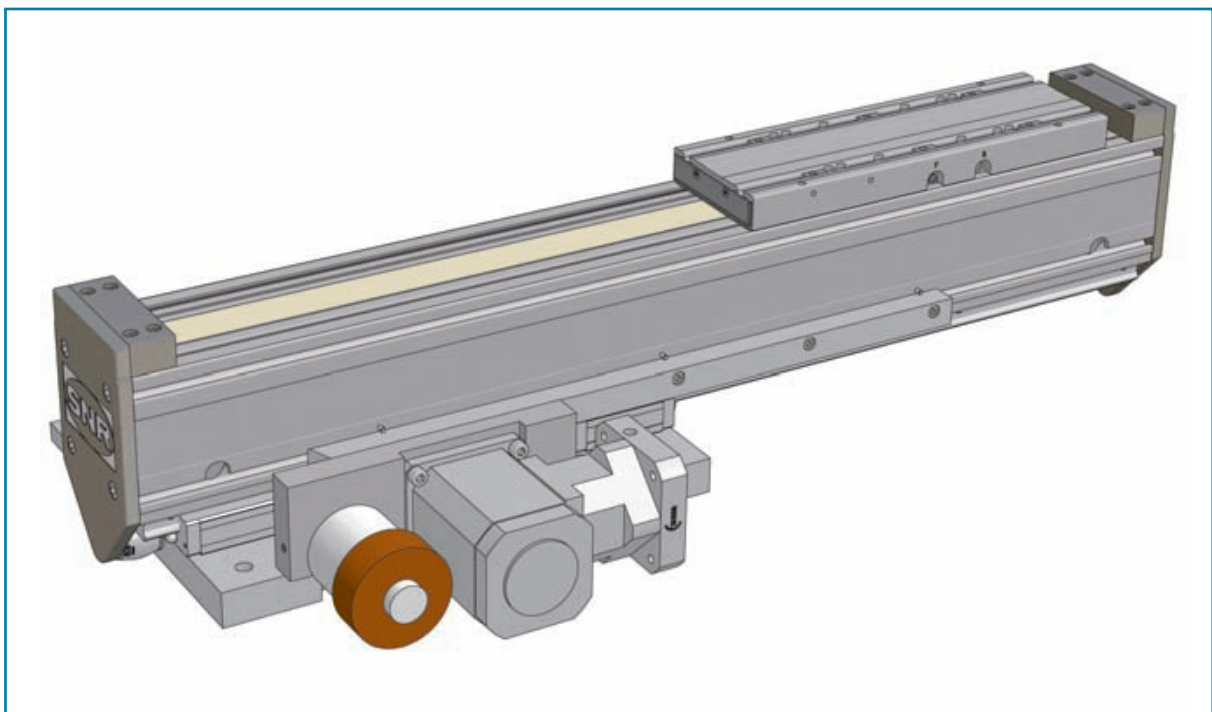
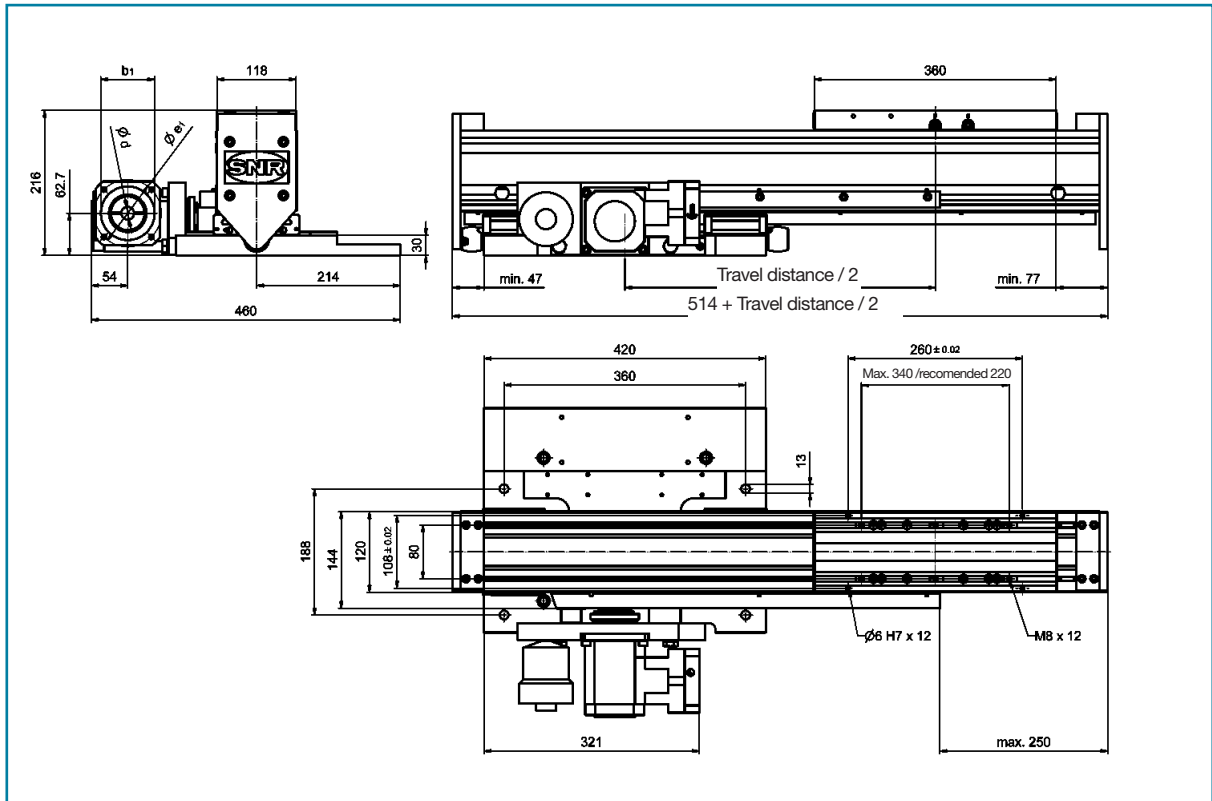

I Loads and torque loads

		Ball rail guide			
ID number	B				
Table length, [mm]	360				
		1-level		2-level	
Loads [N]	dyn.	stat.	dyn.	stat.	
F _y	12.200	41.500	6.900	19.500	
F _z	12.200	41.500	6.900	19.500	
-F _z	12.200	41.500	6.900	19.500	
Torque loads [Nm]	dyn.	stat.	dyn.	stat.	
M _x	470	1.600	220	635	
M _y	1.750	5.900	580	1.650	
M _z	1.750	5.900	580	1.650	

The dynamic load-bearing capacities of the guidance system are based on a nominal service life of 54,000 km.

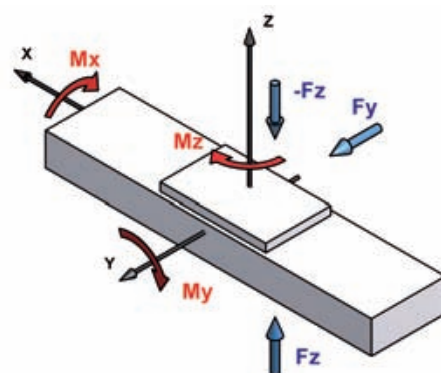

I Technical specifications

Max. traverse rate [m/min]	600
Drive element	Pinion drive, module 2, synchronous belt drives 50AT10
Allowable dynamic working force of the synchronous belt drive [N]	2.500
of the pinion drive [N]	2.880
Max. energy absorption (shock absorber TA37-16) [Nm]	65
Lift per revolution ¹⁾ [mm]	280
Geometrical moment of inertia I _y [cm ⁴]	661,1
Geometrical moment of inertia I _z [cm ⁴]	938,57
Maximal total length [m]	3,0

1) Greater lengths upon request.

		Ball rail guide	
ID number	B		
			1st level
Base mass [kg]	41,3		14,5
Mass per 100 mm of travel distance [kg]	3,9		
Carriage mass [kg]	5,9		

Subject to technical modifications.

AXS160M160 lifting axis

with rack and pinion drive and profile ball rail guide
(vertical installation)

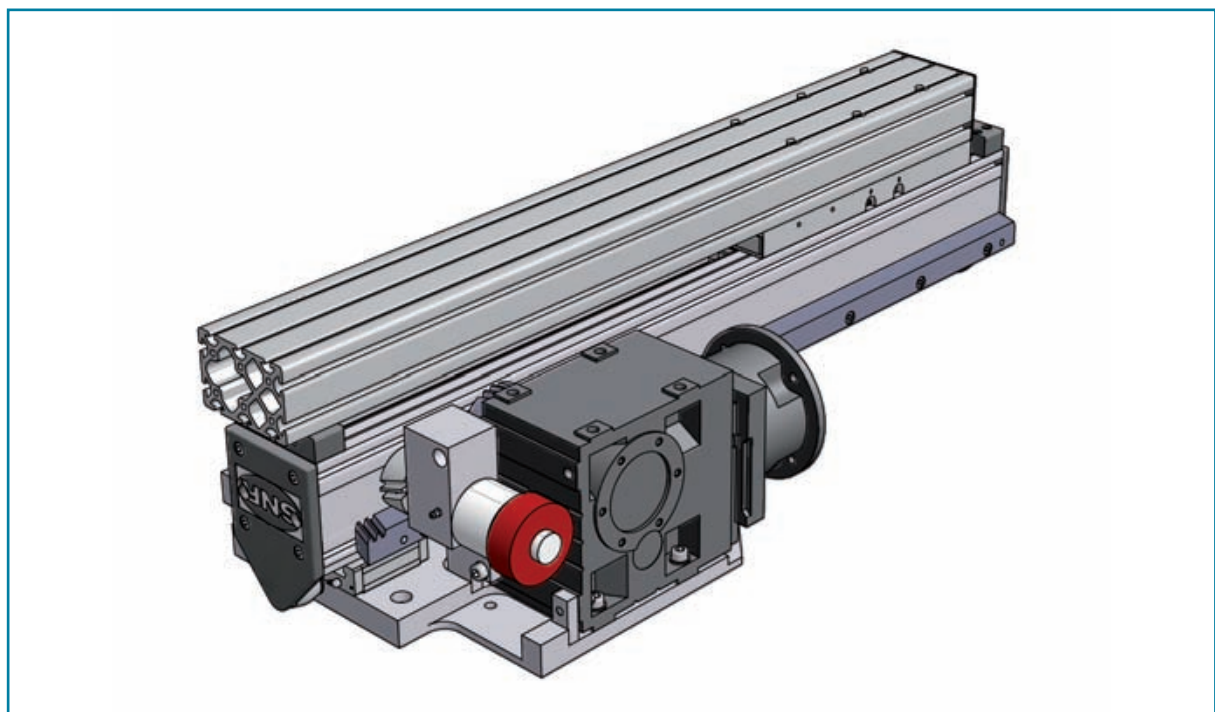
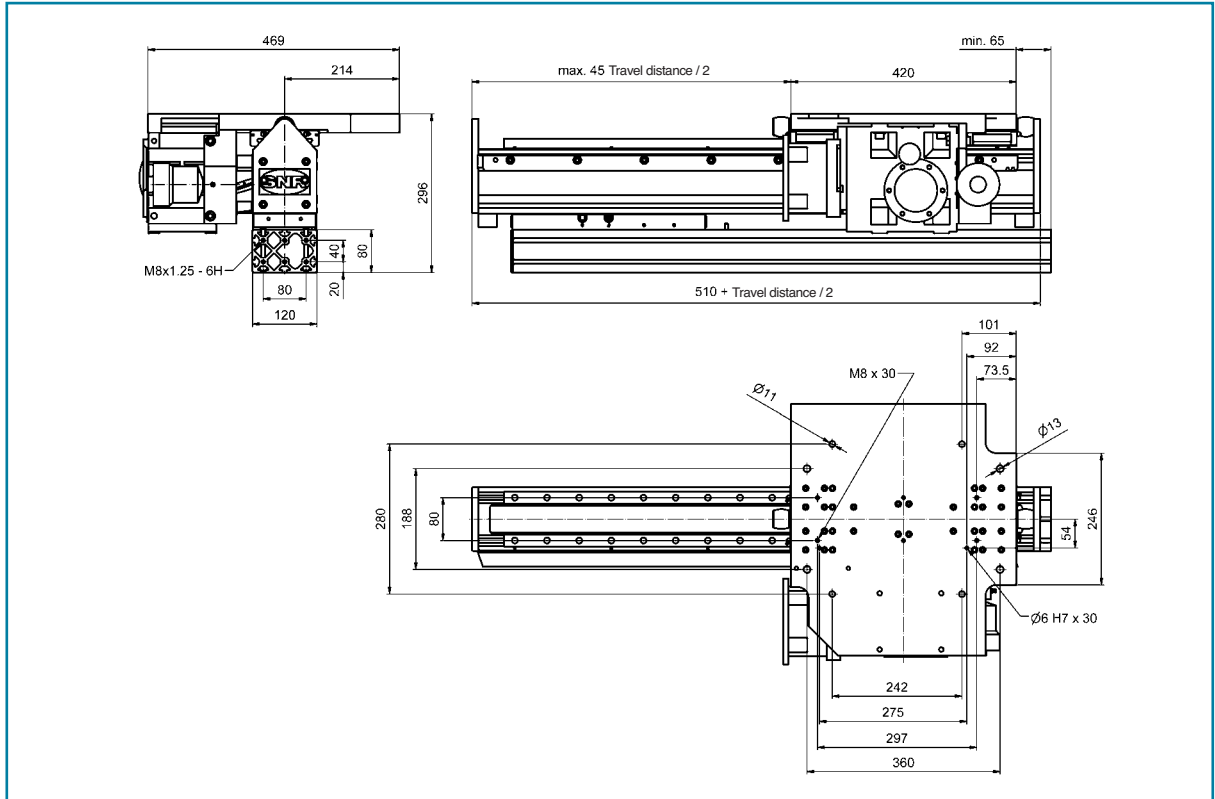

I Loads and torque loads

ID number	Ball rail guide			
	B			
	1-level		2-level	
Loads [N]	dyn.	stat.	dyn.	stat.
F _y	12.200	41.500	6.900	19.500
F _z	12.200	41.500	6.900	19.500
-F _z	12.200	41.500	6.900	19.500
Torque loads [Nm]	dyn.	stat.	dyn.	stat.
M _x	470	1.600	220	635
M _y	1.750	5.900	580	1.650
M _z	1.750	5.900	580	1.650

The dynamic load-bearing capacities of the guidance system are based on a nominal service life of 54,000 km.

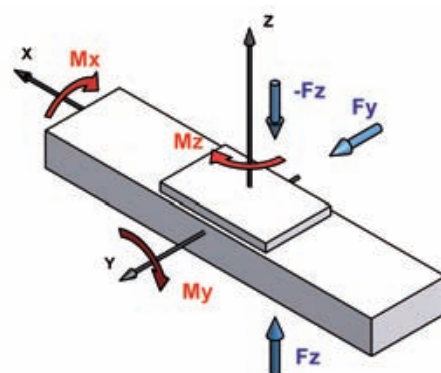

I Technical specifications

Max. traverse rate [m/min]	216
Drive element	Pinion drive, module 3, synchronous belt drives 50AT10
Allowable dynamic working force	
of the synchronous belt drive [N]	2.500
of the pinion drive [N]	5.860
Max. energy absorption (shock absorber TA37-16) [Nm]	65
Lift per revolution ¹⁾ [mm]	500
Geometrical moment of inertia I _y [cm ⁴]	661,1
Geometrical moment of inertia I _z [cm ⁴]	938,57
Maximal total length [m]	3,0

1) Greater lengths upon request.

ID number	Ball rail guide	
	B	
		1st level
Base mass [kg]	70,0	15,4
Mass per 100 mm of travel distance [kg]	4,1	
Carriage mass [kg]	5,9	

Subject to technical modifications.
Masses without gearbox.

AXS200M200 lifting axis

with rack and pinion drive and profile ball rail guide

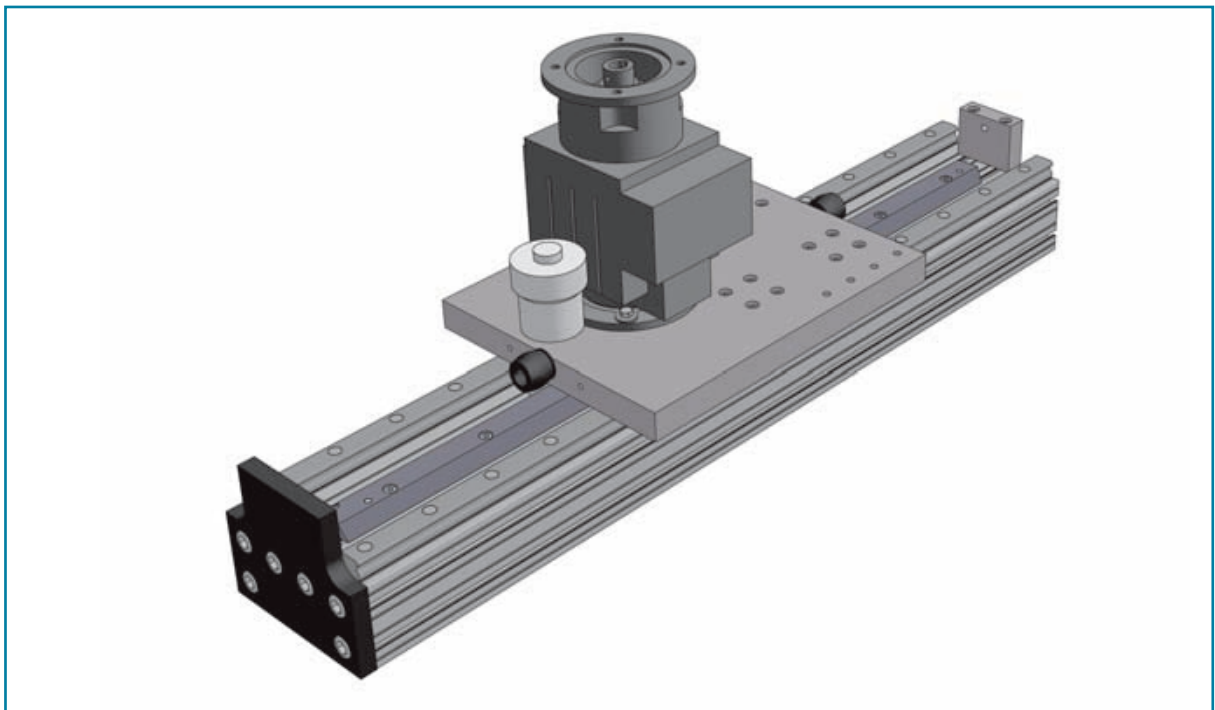
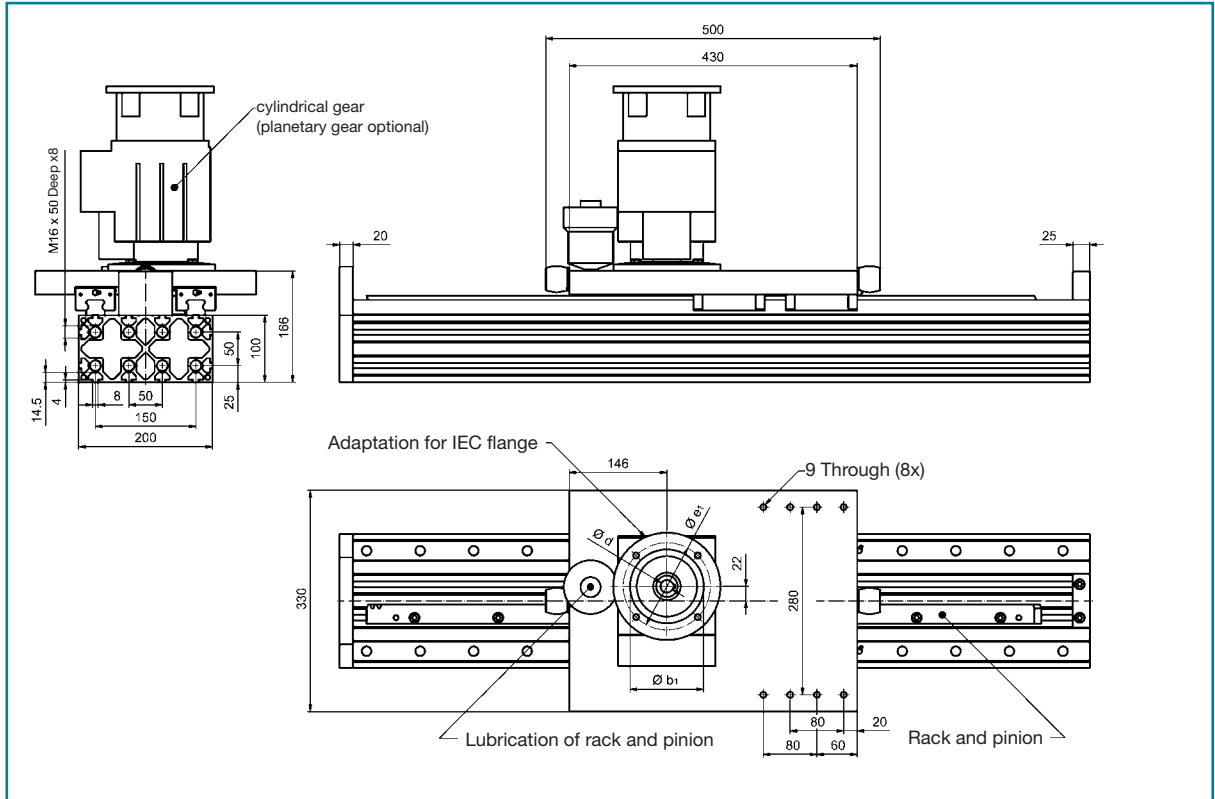

I Loads and torque loads

	Ball rail guide			
ID number	B			
Table length [mm]	430		610	
Application	individual		Y-Z combination ¹⁾	
Loads [N]	dyn.	stat.	dyn.	stat.
F _y	17.400	53.000	17.400	53.000
F _z	17.400	53.000	17.400	53.000
-F _z	17.400	53.000	17.400	53.000
Torque loads [Nm]	dyn.	stat.	dyn.	stat.
M _x	1.200	3.700	1.200	3.700
M _y	1.100	3.400	2.200	6.700
M _z	1.100	3.400	2.200	6.700

The dynamic load-bearing capacities of the guidance system are based on a nominal service life of 54,000 km.

1.) see page 117

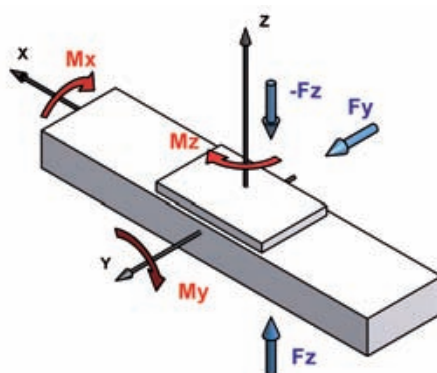

I Technical specifications

Max. traverse rate [m/min]	204
Drive element	Rack and pinion, module 3
Allowable. dyn. working load [N]	6.130
Lift per revolution [mm]	200
Max. energy absorption (shock absorber TA40-16) [Nm]	80
Geometrical moment of inertia I _y [cm ⁴]	3.500
Geometrical moment of inertia I _z [cm ⁴]	1.100
Maximal total length [m]	6,0

	Ball rail guide
ID number	B
Base mass [kg]	35,0
Mass per 100 mm of travel distance [kg]	3,5
Carriage mass [kg]	17,0

Subject to technical modifications.

Masses without gearbox.

AXS200M250 lifting axis

with rack and pinion drive and profile ball rail guide

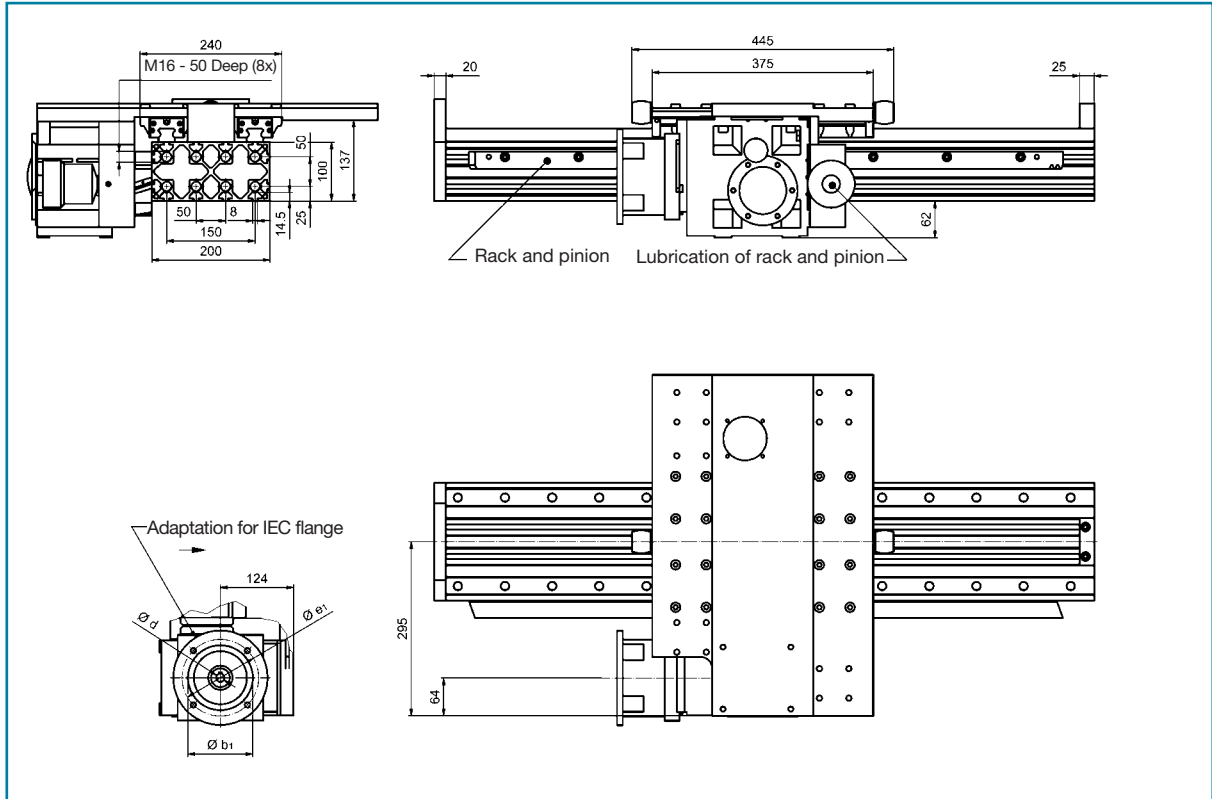

• Linear axis only in combination with gantry axis AXS280M200 (see. page 117)

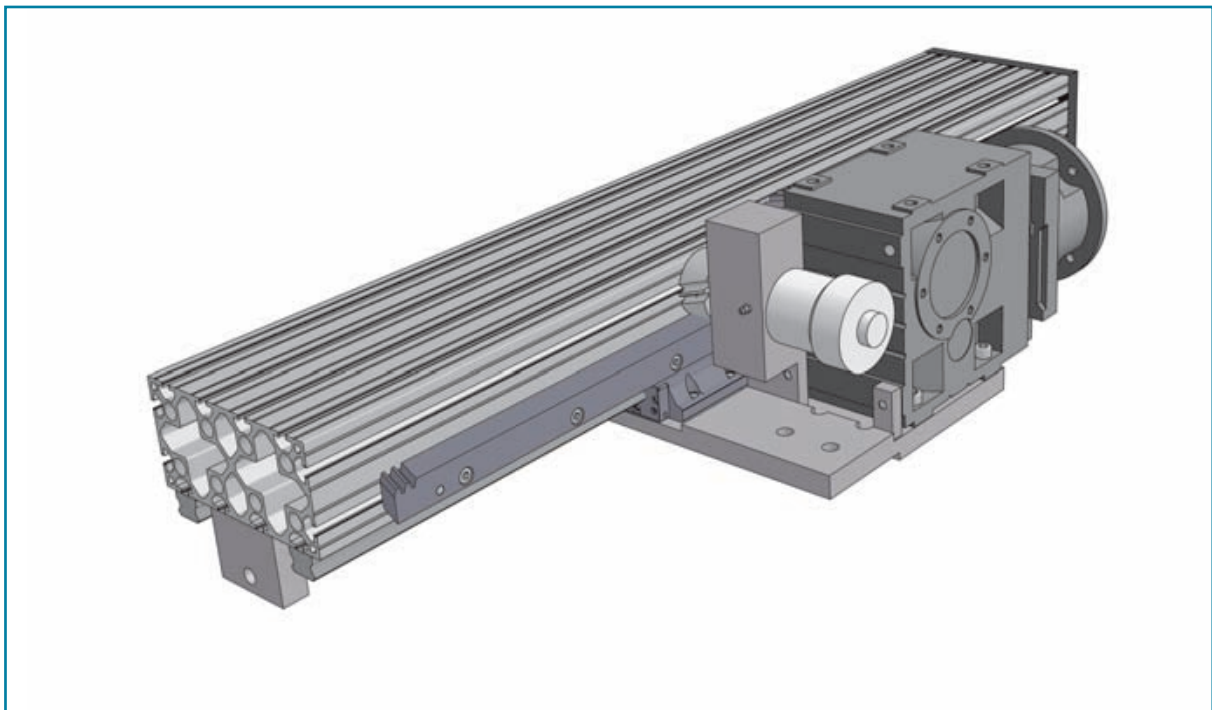

I Loads and torque loads

Ball rail guide		
ID number	B	
Table length [mm]	375	
Loads [N]	dyn.	stat.
F _y	17.400	53.000
F _z	17.400	53.000
-F _z	17.400	53.000
Torque loads [Nm]	dyn.	stat.
M _x	1.200	3.700
M _y	1.850	5.700
M _z	1.850	5.700

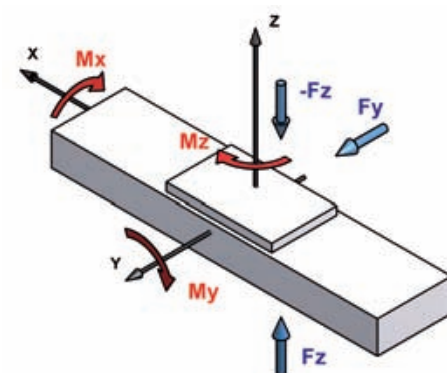

The dynamic load-bearing capacities of the guidance system are based on a nominal service life of 54,000 km.

I Technical specifications

Max. traverse rate [m/min]	108
Drive element	Rack and pinion, module 3
Allowable. dyn. working load [N]	5.860
Lift per revolution [mm]	250
Max. energy absorption (shock absorber TA40-16) [Nm]	80
Geometrical moment of inertia I _y [cm ⁴]	3.500
Geometrical moment of inertia I _z [cm ⁴]	1.100
Maximal total length [m]	6,0

Ball rail guide	
ID number	B
Base mass [kg]	39,5
Mass per 100 mm of travel distance [kg]	3,5
Carriage mass [kg]	23,0

Subject to technical modifications.
Masses without gearbox.

AXS230M320 lifting axis

with rack and pinion drive and profile ball rail guide

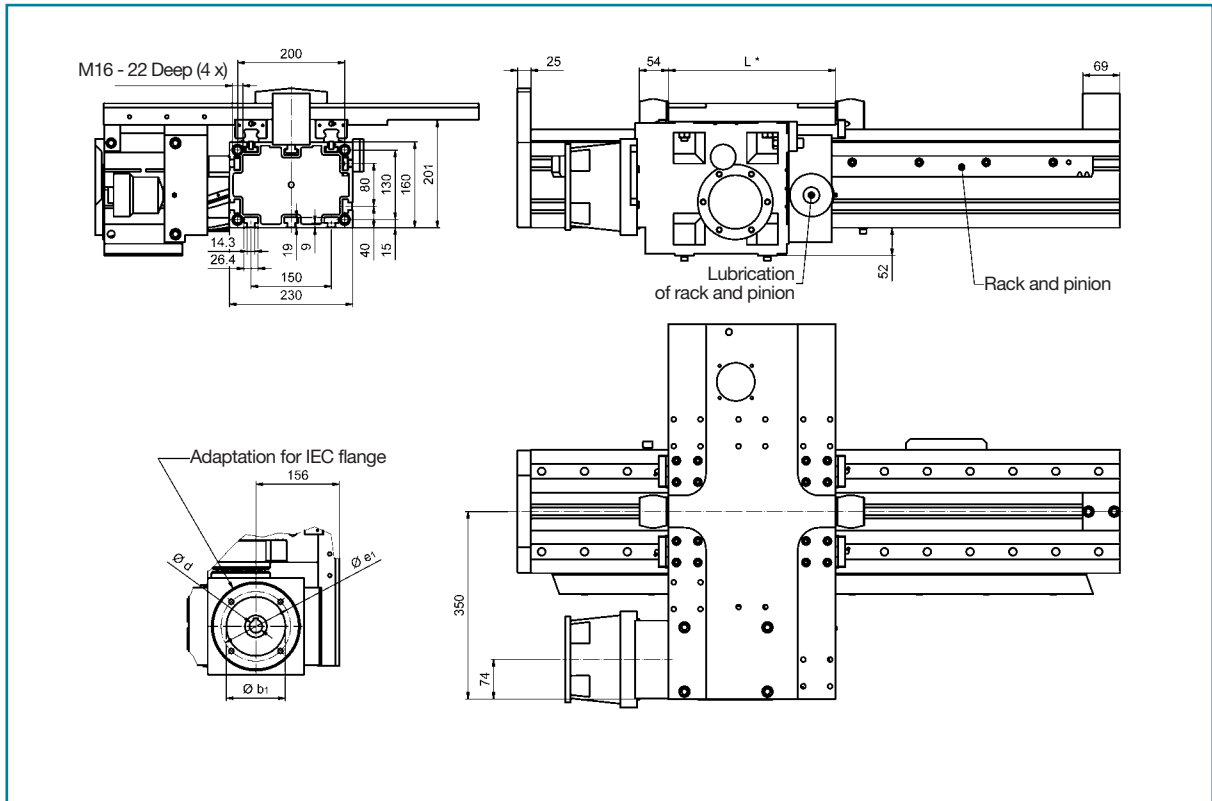

• Linear axis only in combination with gantry axis AXS280 and AXS460 (see page 113).

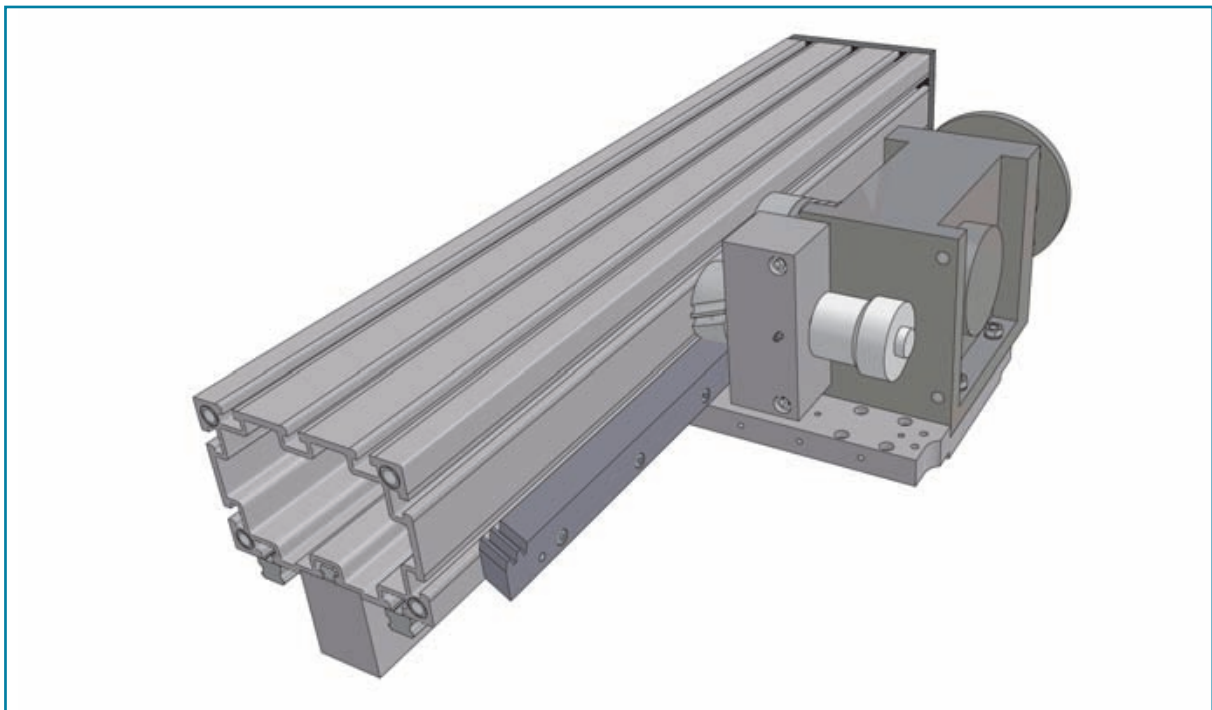

I Loads and torque loads

Ball rail guide				
ID number	B			
Table length L [mm]	312		492	
Loads [N]	dyn.	stat.	dyn.	stat.
F _y	17.400	53.000	17.400	53.000
F _z	17.400	53.000	17.400	53.000
-F _z	17.400	53.000	17.400	53.000
Torque loads [Nm]	dyn.	stat.	dyn.	stat.
M _x	1.200	3.700	1.200	3.700
M _y	1.850	5.700	3.000	9.300
M _z	1.850	5.700	3.000	9.300

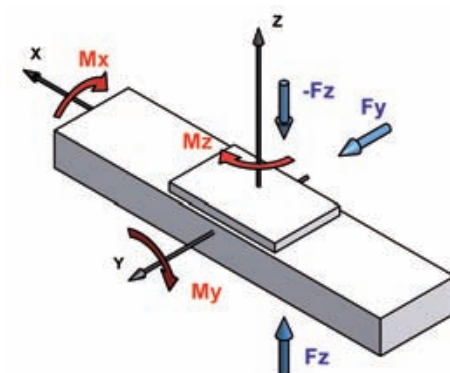

The dynamic load-bearing capacities of the guidance system are based on a nominal service life of 54,000 km.

I Technical specifications

Max. traverse rate [m/min]	150
Drive element	Rack and pinion, module 4
Allowable. dyn. working load [N]	10.750
Lift per revolution [mm]	320
Max. energy absorption (shock absorber TA62-25) [Nm]	280
Geometrical moment of inertia I _y [cm ⁴]	8.850
Geometrical moment of inertia I _z [cm ⁴]	6.780
Maximal total length [m]	10

Ball rail guide	
ID number	B
Base mass [kg]	56,0
Mass per 100 mm of travel distance [kg]	4,4
Carriage mass [kg]	30,5

Subject to technical modifications.
Masses without gearbox.

AXS280M400 lifting axis

with rack and pinion drive and profile ball rail guide

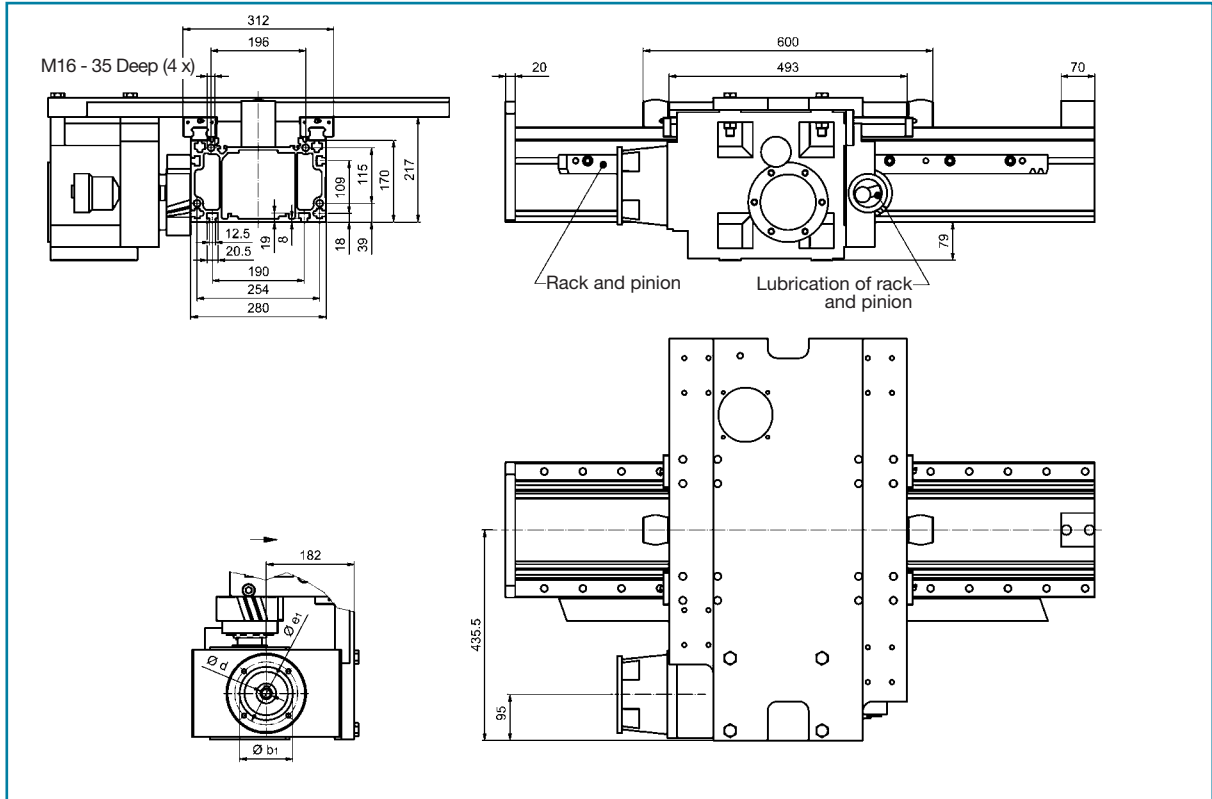

• Linear axis only in combination with gantry axis AXS460M250 (see page 117).

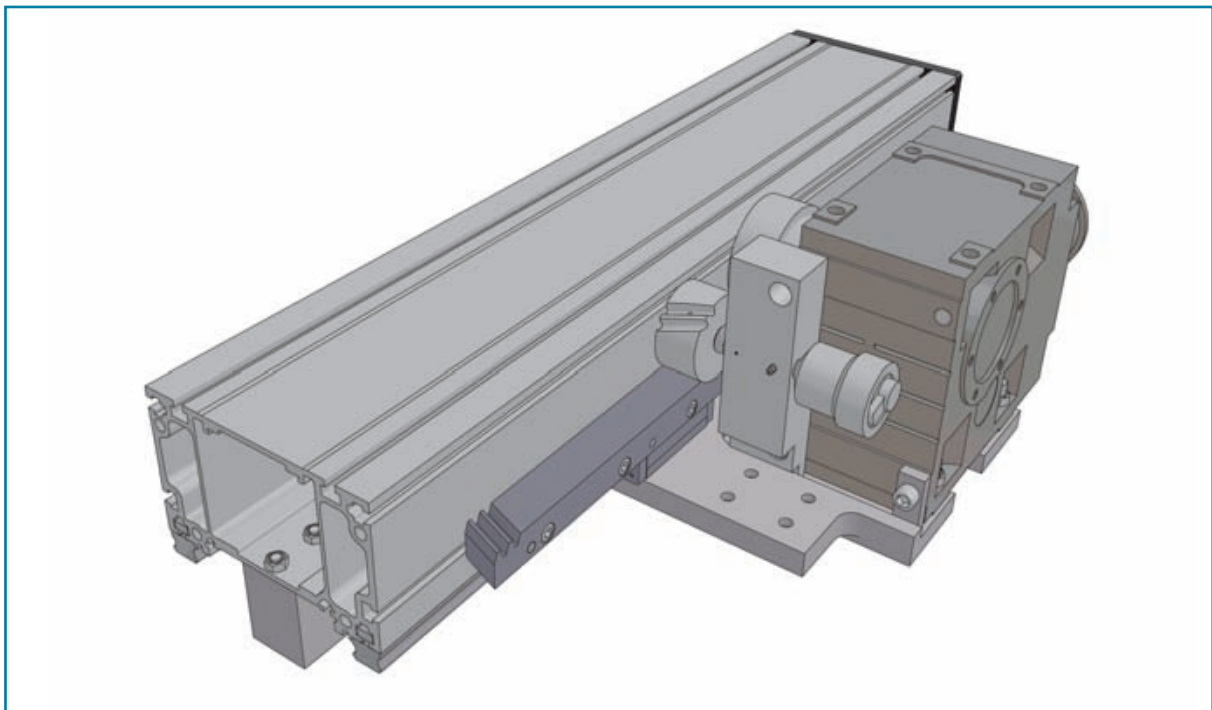

I Loads and torque loads

Ball rail guide		
ID number	B	
Table length [mm]	493	
Loads [N]	dyn.	stat.
Fy	28.000	100.000
Fz	28.000	100.000
-Fz	28.000	100.000
Torque loads [Nm]	dyn.	stat.
Mx	3.000	10.500
My	4.300	15.500
Mz	4.300	15.500

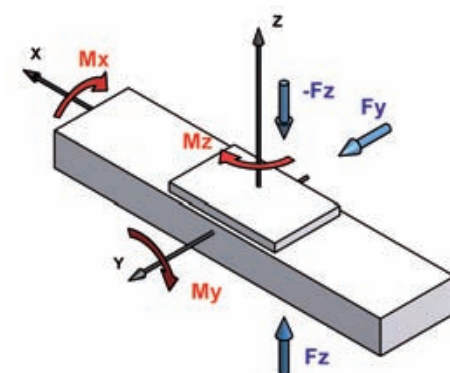

The dynamic load-bearing capacities of the guidance system are based on a nominal service life of 54,000 km.

I Technical specifications

Max. traverse rate [m/min]	198
Drive element	Rack and pinion, module 5
Allowable. dyn. working load [N]	16.240
Lift per revolution [mm]	400
Max. energy absorption (shock absorber TA62-25) [Nm]	280
Geometrical moment of inertia Iy [cm ⁴]	14.645
Geometrical moment of inertia Iz [cm ⁴]	7.958
Maximal total length [m]	10

Ball rail guide	
ID number	B
Base mass [kg]	96,0
Mass per 100 mm of travel distance [kg]	5,9
Carriage mass [kg]	54,5

Subject to technical modifications.
Masses without gearbox.

AXS280Z gantry axis

with rack and pinion drive and profile ball rail guide

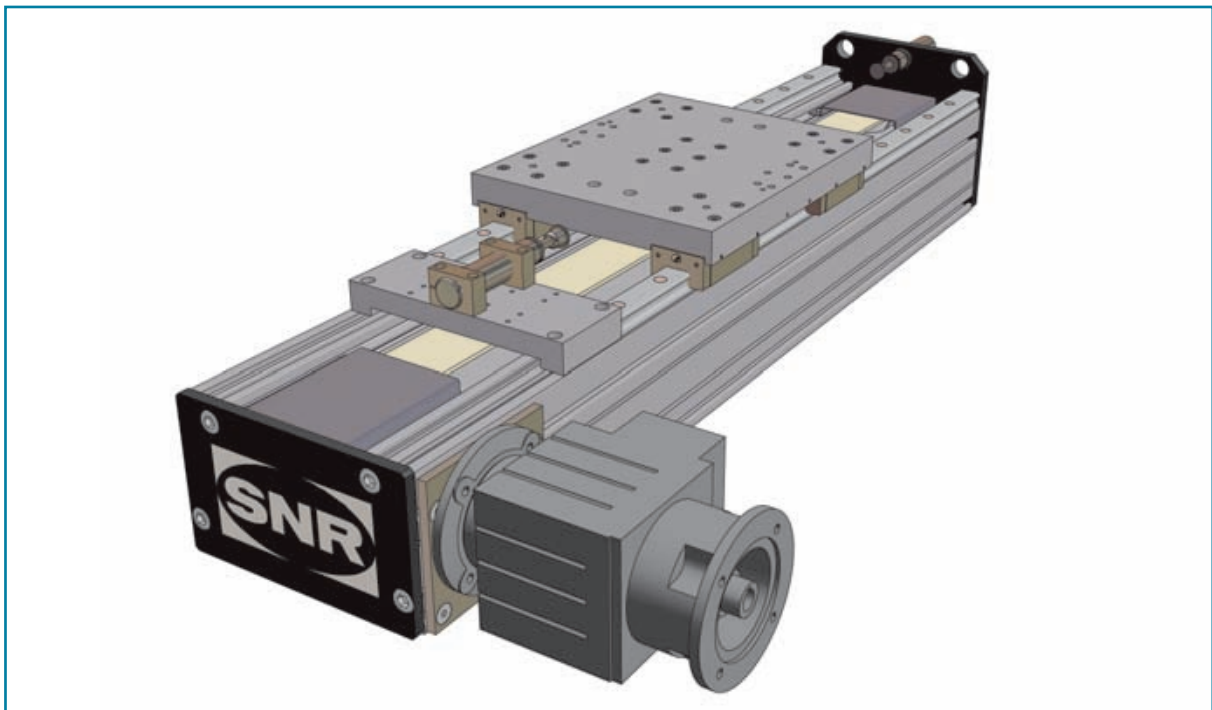
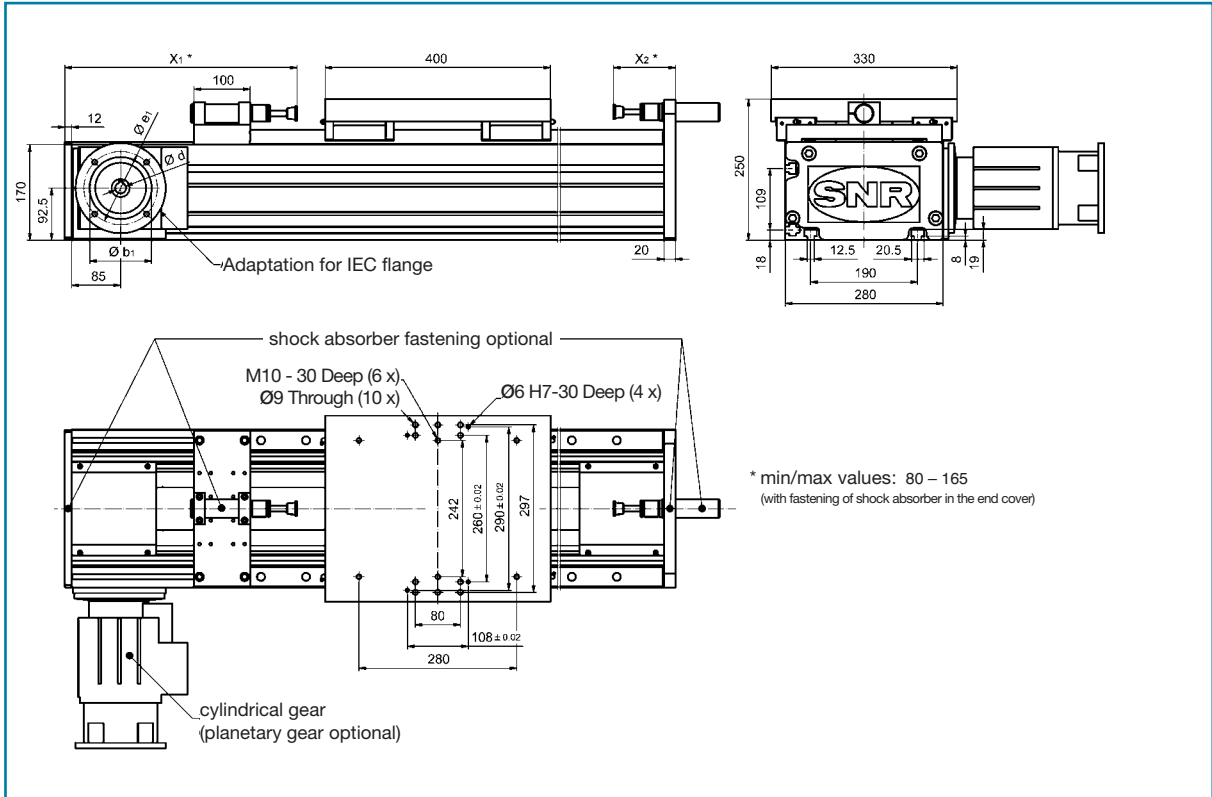

I Loads and torque loads

Ball rail guide		
ID number	B	
Table length [mm]	400	
Loads [N]	dyn.	stat.
Fy	24.000	77.000
Fz	24.000	77.000
-Fz	24.000	77.000
Torque loads [Nm]	dyn.	stat.
Mx	2.600	8.300
My	2.950	9.400
Mz	2.950	9.400

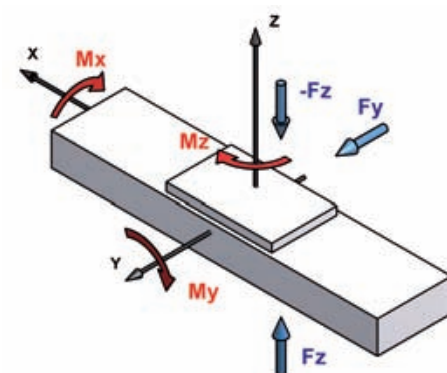

The dynamic load-bearing capacities of the guidance system are based on a nominal service life of 54,000 km.

I Technical specifications

Max. traverse rate [m/min]	300
Drive element	Synchronous belt 75AT10
Allowable. dyn. working load [N]	4.000
Lift per revolution [mm]	480
Max. energy absorption per end absorber [Nm]	900
Idling speed torque [Nm]	9
Inertia [kgcm ²]	227,6
Geometrical moment of inertia Iy [cm ⁴]	14.645
Geometrical moment of inertia Iz [cm ⁴]	7.958
Maximal total length [m]	10 (one part) ¹⁾

1) Greater lengths upon request.

Ball rail guide	
ID number	B
Base mass [kg]	78,0
Mass per 100 mm of travel distance [kg]	4,6
Carriage mass [kg]	19,0

Subject to technical modifications.
Masses without gearbox.

AXS280M200 gantry axis with rack and pinion drive and profile ball rail guide

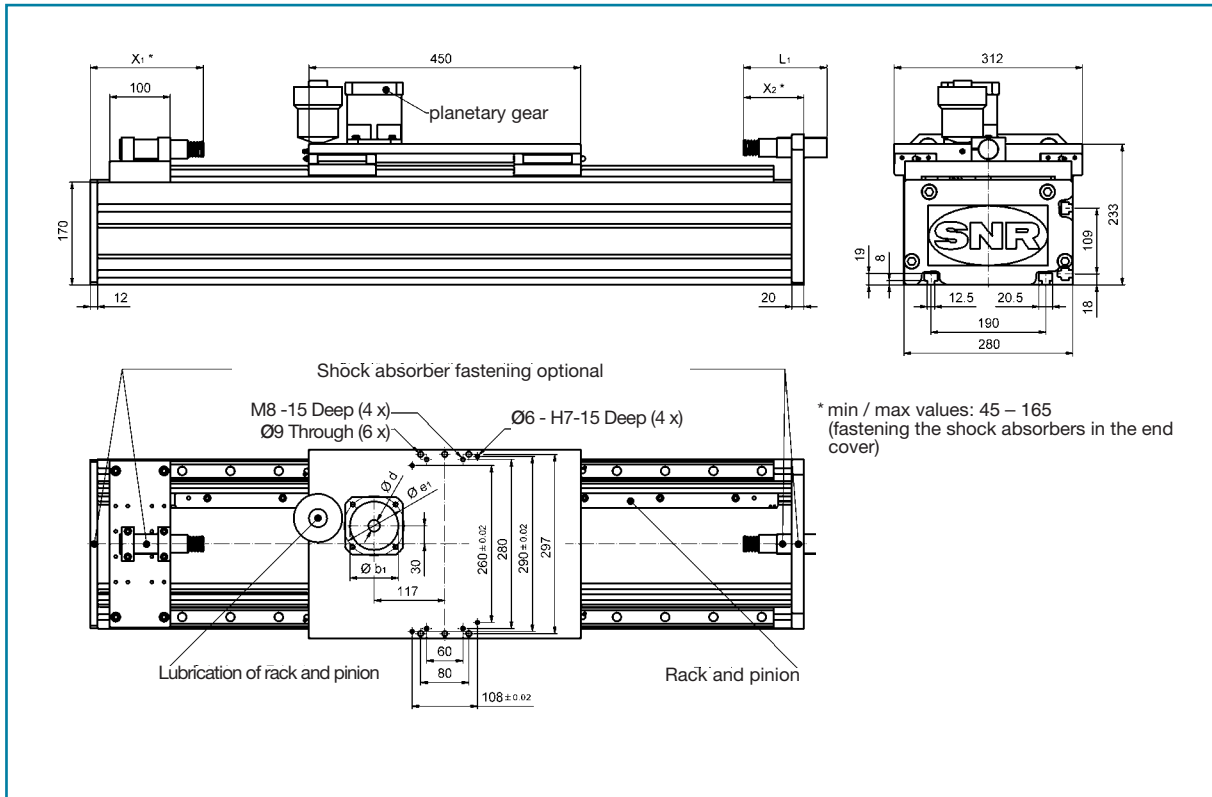

- **Description:** multi-purpose use, for combination with lifting axes (see page 117).

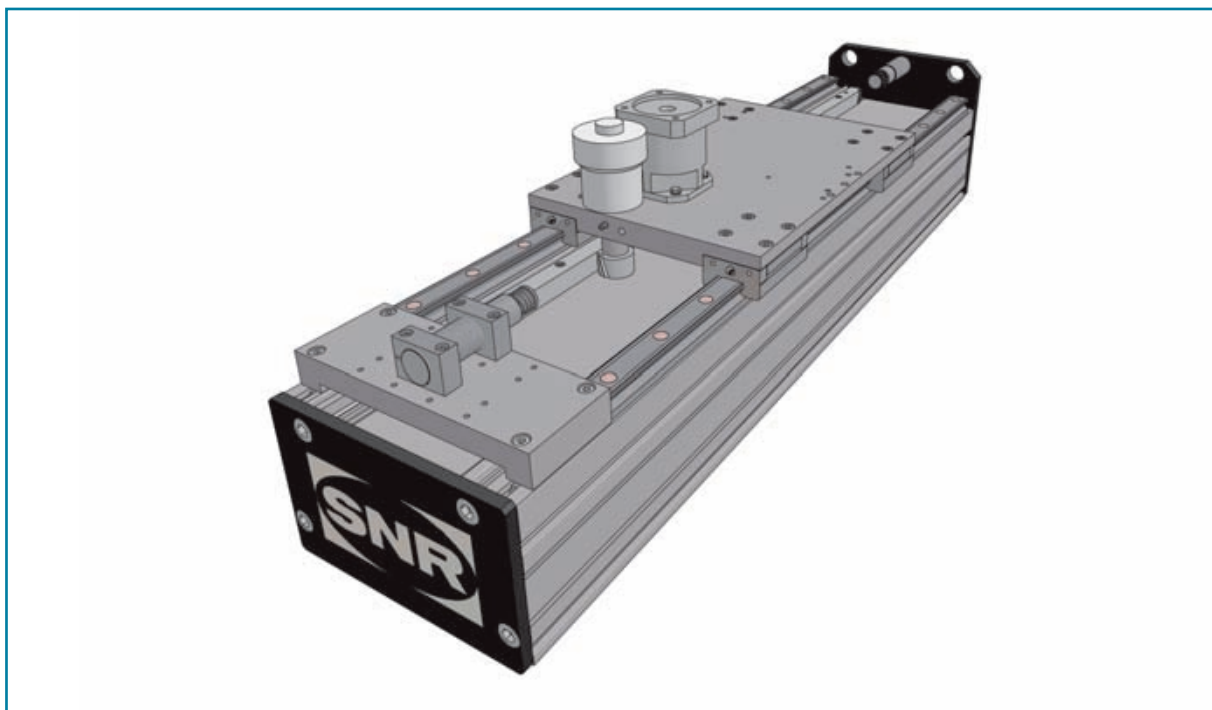

I Loads and torque loads

Ball rail guide		
ID number	B	
Table length [mm]	450	
Loads [N]	dyn.	stat.
F _y	24.000	77.000
F _z	24.000	77.000
-F _z	24.000	77.000
Torque loads [Nm]	dyn.	stat.
M _x	2.600	8.300
M _y	3.500	11.200
M _z	3.500	11.200

The dynamic load-bearing capacities of the guidance system are based on a nominal service life of 54,000 km.

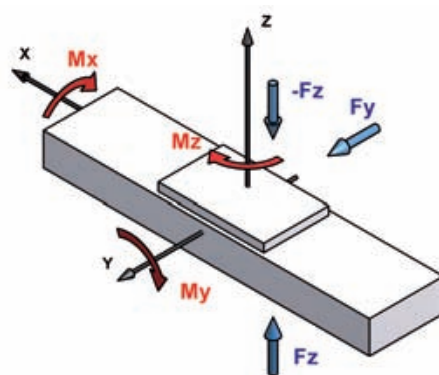

I Technical specifications

Max. traverse rate [m/min]	198
Drive element	Rack and pinion, module 2
Allowable. dyn. working load [N]	3.190
Lift per revolution [mm]	200
Max. energy absorption per end absorber [Nm]	900
Geometrical moment of inertia I _y [cm ⁴]	14.645
Geometrical moment of inertia I _z [cm ⁴]	7958
Maximal total length [m]	10 ¹⁾

1) Greater lengths upon request.

Caged ball linear guide	
ID number	B
Base mass [kg]	52,0
Mass per 100 mm of travel distance [kg]	4,9
Carriage mass [kg]	16,5

Subject to technical modifications.
Masses without gearbox.

AXS460M250 gantry axis with rack and pinion drive and profile ball rail guide

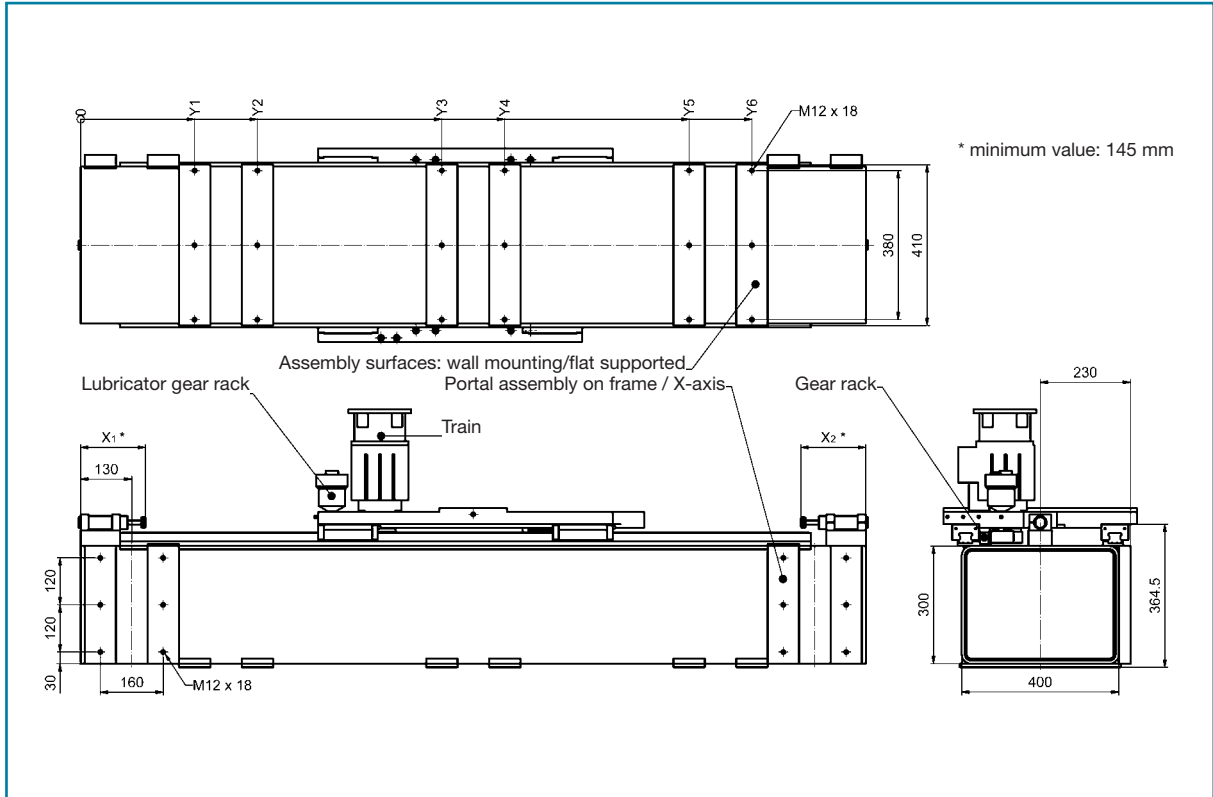

• Other Dimensions (s. page 117)

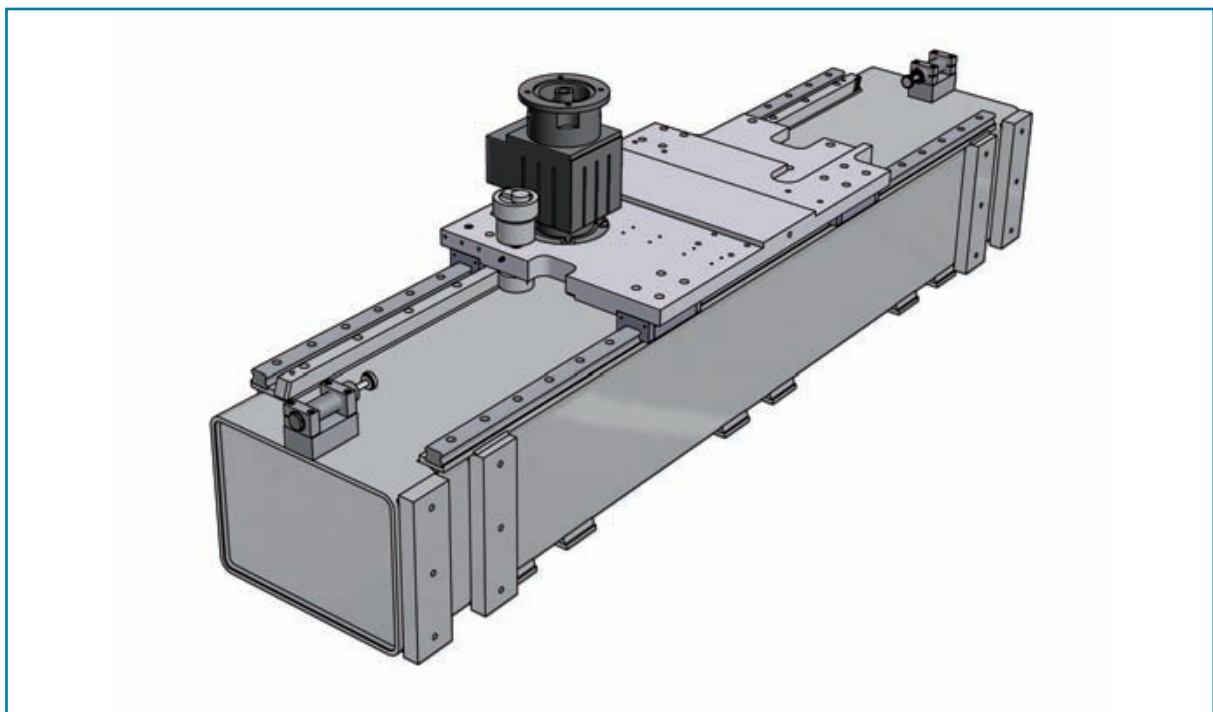

I Loads and torque loads

	Ball rail guide	
ID number	B	
Table length [mm]	600	
Loads [N]	dyn.	stat.
Fy	28.000	100.000
Fz	28.000	100.000
-Fz	28.000	100.000
Torque loads [Nm]	dyn.	stat.
Mx	4.500	16.000
My	5.800	21.000
Mz	5.800	21.000

The dynamic load-bearing capacities of the guidance system are based on a nominal service life of 54,000 km.

I Technical specifications

Max. traverse rate [m/min]	300
Drive element	Rack and pinion, module 3
Allowable dynamic working load [N]	5.860
Lift per revolution [mm]	250
Max. energy absorption per end absorber [Nm]	900
Geometrical moment of inertia Iy [cm ⁴]	88.490
Geometrical moment of inertia Iz [cm ⁴]	54.170
Maximal total length [m]	10 ¹⁾

1) Greater lengths upon request.

	Ball rail guide
ID number	B
Base mass [kg]	139,5
Mass per 100 mm of travel distance [kg]	8,9
Carriage mass [kg]	46,5

Subject to technical modifications.
Masses without gearbox.

Drive adaptation AXC / AXLT / AXDL



I Integrated planetary gearbox

AXC and AXDL-series SNR linear axes with synchronous belt drives can be configured with gearboxes according to specifications and application. The integrated planetary gearboxes are used in applications in which the highest level of precision and dynamism is required. The torque is reduced, and the number of revolutions increased, thanks to the use of integrated planetary gearboxes.

A pulley is friction-lock mounted on the output shaft of the gearbox ensures zero-backlash torque transmission. Since the system is fitted directly, clutch case and clutch are not needed; this results in a compact arrangement. Only engines with a smooth shaft should be used.

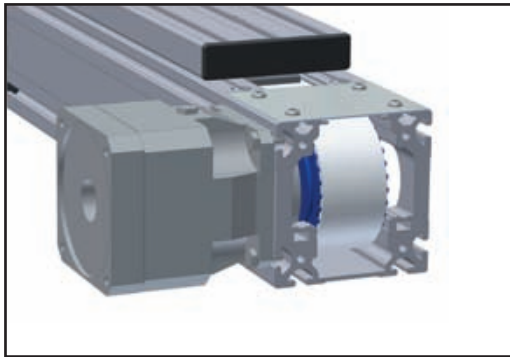

AXDL_Z series

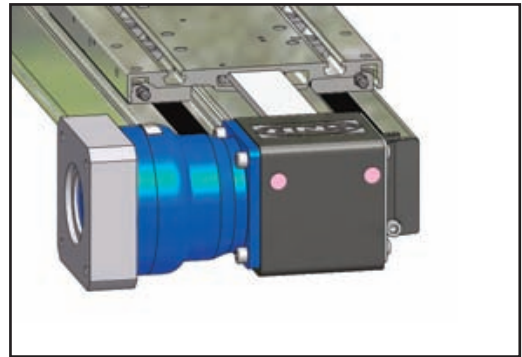

AXC_Z series

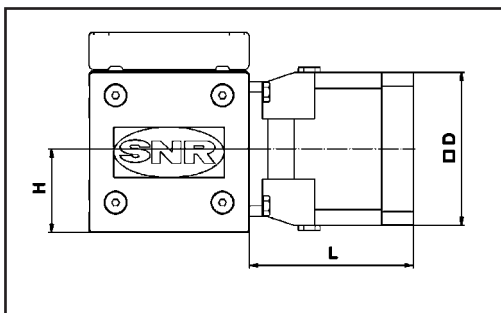

AXDL_Z series

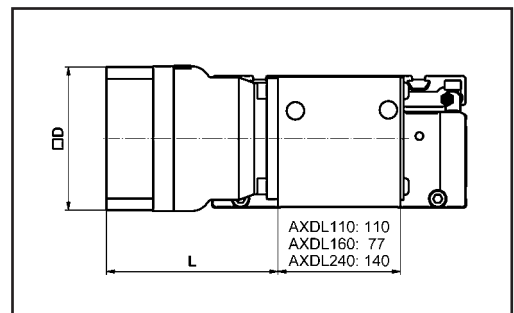

AXC_Z series

• ID number of drive adaptation

D number	C	D	E	F	G	H	I	J	K	L	M	N	O	P	Q	R	S	T	U	V	W	Y
Centering b [mm]	40	50	50	60	60	60	60	70	80	80	95	95	95	95	110	110	110	110	110	110	130	130
Reference circle e [mm]	63	70	95	75	75	90	90	90	100	100	115	115	130	130	130	130	145	145	165	165	165	165
Thread	M4	M4	M6	M5	M5	M5	M5	M5	M6	M6	M8	M8	M8	M8	M8	M8	M8	M8	M10	M10	M10	M10
Diameter of shaft [mm]	9	14	14	11	14	11	14	14	14	19	19	24	19	24	19	24	19	24	19	24	24	32

Please use the ID number to label the desired drive adaptation in the order description.
ID number X: special size or all dimensions not listed.

	AXC40			
	1-level		2-level	
Translations i	5 / 7	10	25 / 35 / 50 / 70	100
Rated torque on gearbox [Nm]	5,7	5,2	5,7	5,2
Max. acceleration torque [Nm] ¹⁾	11,5	10,5	11,5	10,5
Permissible average input speed [min ⁻¹]	4.000		4.000	
Max. input speed [min ⁻¹]	8.000		8.000	
Backlash [arcmin]	≤ 20		≤ 25	
Mass [kg]	0,31		0,52	
Diameter of motor shaft d [mm]	9		9	
Moment of inertia [kgcm ²] for d	0,04		0,04	
Overall length L [mm] for d	59		74,5	
Flange dimension D [mm]	min. 40			

	AXC60			AXDL110				
	1-level		2-level	1-level			2-level	
Translations i	4/5/7	10	16 / 20 / 25 / 28 / 35 / 40 / 50 / 70	3	4/5/7	10	16 / 20 / 25 / 28 / 35 / 40 / 50 / 70	
Rated torque on gearbox [Nm]	16	12	16	17	26	17	26	
Max. acceleration torque [Nm] ¹⁾	22	18	22	30	42	32	42	
Permissible average input speed [min ⁻¹]	4.500		4.500	3.300	3.300 - 4.000	4.000	4.400 - 5.500	
Max. input speed [min ⁻¹]	8.000		8.000	6.000			6.000	
Backlash [arcmin]	≤ 6		≤ 8	Standard: ≤ 4 / Reduced: ≤ 2			Standard: ≤ 6 / Reduced: ≤ 4	
Mass [kg]	1,1		1,7	1,9			2	
Diameter of motor shaft d [mm]	14	19	max. 14	11	14	19	11	14
Moment of inertia [kgcm ²] for d	0,07-0,14	0,39-0,43	0,07 - 0,14	0,09-0,21	0,17-0,28	0,49-0,61	0,056-0,077	0,15 - 0,17
Overall length L [mm] for d	73,5	93	105,5	90	94	106	108	116
Flange dimension D [mm]	55 - 100			min. 70		min. 90	min. 60	min. 70

	AXC80 + AXDL160					
	1-level			2-level		
Translations i	3	4/5/7	10	16 / 20 / 25 / 28 / 35 / 40 / 50 / 70		100
Rated torque on gearbox [Nm]	47	75	52	75		52
Max. acceleration torque [Nm] ¹⁾	85	110	95	110		90
Permissible average input speed [min ⁻¹]	2.900	2.900 - 3.100	3.100	3.500 - 4.500		4.500
Max. input speed [min ⁻¹]	6.000			6.000		
Backlash [arcmin]	Standard: ≤ 4 / Reduced: ≤ 2			Standard: ≤ 6 / Reduced: ≤ 4		
Mass [kg]	3,9			3,6		
Diameter of motor shaft d [mm]	14	19	24	11	14	19
Moment of inertia [kgcm ²] for d	0,38 - 0,86	0,54 - 1,03	1,91 - 2,40	0,09 - 0,16	0,16 - 0,23	0,49 - 0,55
Overall length L [mm] for d (AXC80 + 8 mm)	108	112	130	119	123	136
Flange dimension D [mm]	min. 90		min. 120	min. 70		min. 90

	AXC120 + AXDL240							
	1-level				2-level			
Translations i	3	4	5	7	10	16 / 20 / 25 / 28 / 35 / 40 / 50 / 70		100
Rated torque on gearbox [Nm]	120	180	175	170	120	170 - 180		120
Max. acceleration torque [Nm] ¹⁾	235	315		235	315		235	
Permissible average input speed [min ⁻¹]	2.500			2.800	3.100 - 4.500		4.200	
Max. input speed [min ⁻¹]	4.500				4.500			
Backlash [arcmin]	Standard: ≤ 3 / Reduced: ≤ 1				Standard: ≤ 5 / Reduced: ≤ 3			
Mass [kg]	7,7				7,9			
Diameter of motor shaft d [mm]	19	24	28	38	14	19	24	
Moment of inertia [kgcm ²] for d	1,38 - 3,29	2,07 - 3,99	1,68 - 3,01	9,14 - 11,1	0,37 - 0,64	0,54 - 0,81	1,91 - 2,18	
Overall length L [mm] for d	122	129		156	142	146	164	
Flange dimension D [mm]	min. 120			min. 150	min. 90		min. 120	

1) Observed permitted operating load of linear axis.



Adapter/coupling cone for synchronous belt drive AXC_Z / AXDL_Z

In the simplest type of linking, the drive shaft of the gearbox or motor is directly inserted into the hollow shaft of the driving belt pulley. The drive is screwed down through a flat adapter plate onto the linear axis. The feather key provides positive power transmission. However, the requirement for this is that the output shaft diameter coincides with the respective hollow shaft diameter of the axis (see axis data sheet).

However, adaptation via the integrated clutch in combination with a coupling cone is more common. The axis-side coupling is screwed down onto the driving belt pulley and due to the friction-lock torque transfer offers optimal operational safety even at high speeds. A large selection of coupling cones is available for standard drives with a standardized B5 flange. Drives with smooth shaft and shaft with feather key can be used.

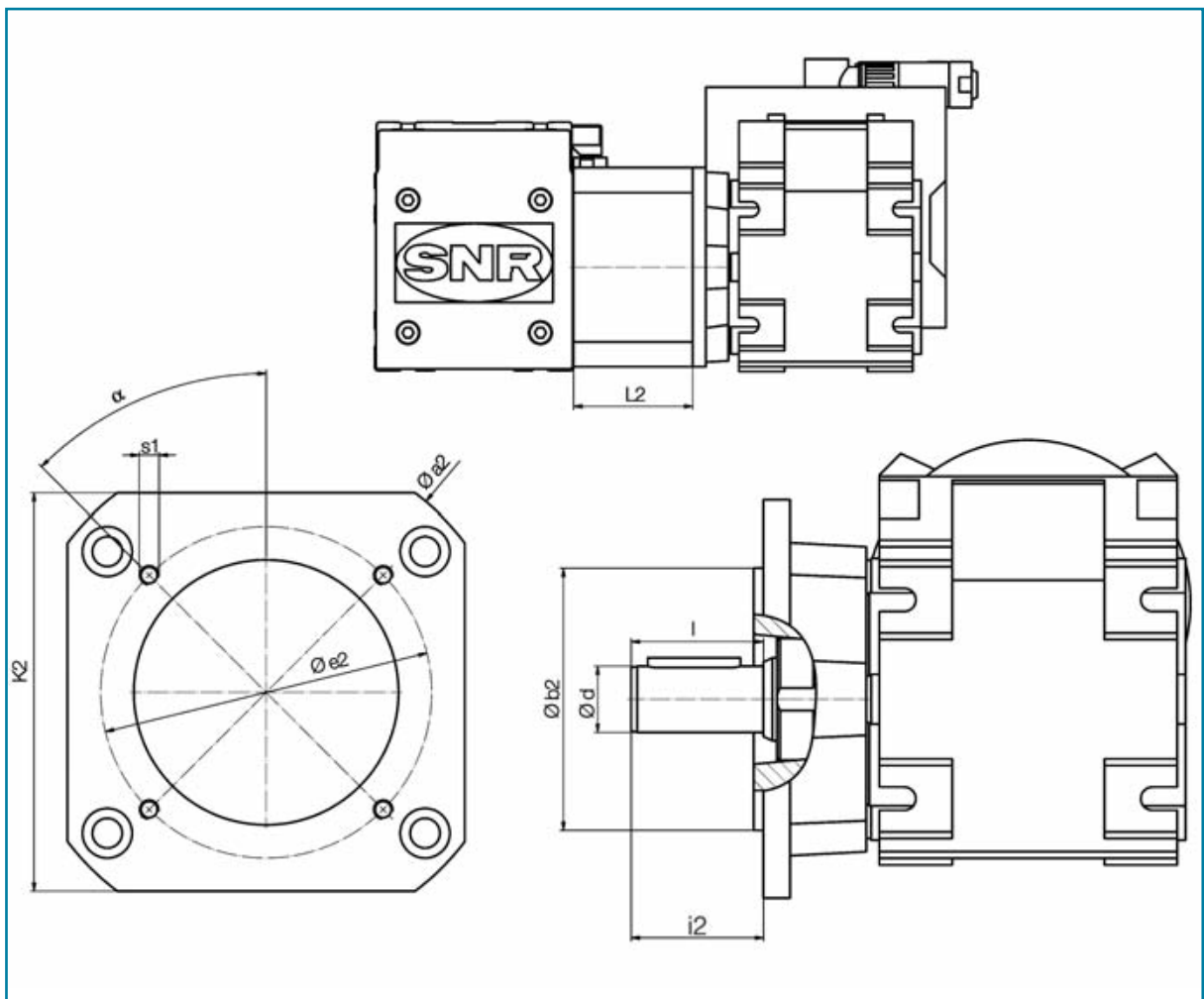

I Drive adapter flange with interlocking connection

Size ID for drive design corresponds to diameter d of the inclusive plug-in shaft with model E0.

Linear axis	ID number	Model	e2	α	s ₁	b ₂	d	i ₂ max.	i _{2-l} max.	k ₂	a ₂	L ₂
AXC40ZF	A	VC065-E0	54	0°	4 x Ø 6,5	44	12	-	20	-	64,5	20,5
	B	B5 C100	80	45°	4 x M6 x 8	60	9	36	9	-	100	9
AXC60ZF/AF	A	B14 C60	52	45°	4 x Ø 5,5	40	14	47	5	60	-	5
	B	VC065-E0	54	0°	4 x Ø 6,5	44	14	-	18	70	80	18
	C	B5 C120	100	45°	4 x M6x8	80	14	50	8	100	120	8
AXC80ZF/AF	A	B14 C80	70	45°	4 x Ø 6,5	60	20	71	12	82	-	12
	B	GST04-2x-VCR	61	90°	6 x Ø 5,5	48	20	71	12	80	-	12
	C	GKR03-2x-VCR	70	0°	4 x Ø 6,5	55*	20	69	10	82	100	10
	D	VC065-E0	54	0°	4 x Ø 6,5	44	12	-	20	82	-	20
	E	B5 C120	100	45°	4 x M6x12	80	20	72	12,5	-	120	12,5
AXC120ZF/AF	A	B5 C120	100	45°	4 x M6x12	80	30	107	13	120	-	13
	B	GST06-2x-VCR	90	0°/90°	6 x Ø 9	70	30	108	14	120	150	14
	C	B5 C200	165	45°	4 x M10x20	130	30	119	25	-	200	25

* Centring by interlocking on the adaptation plate

I Interlocking and force-fit connection with coupling and coupling cone

Linear axis	ID number	Model	e2	α	s ₁	b ₂	d min.	d max.	i ₂ max.	i _{2-l} max.	k ₂	a ₂	L ₂
AXC40ZG	A	B5 TK63	63	45°	4 x M4x8	40	6	10	23	7	54	72	37
AXC60ZG/AG	A	LP70	62	0°	4 x Ø 5,5	52	16	16	36	8	70	80	58
	B	LP90	80	0°	4 x Ø 6,5	68	20	24	46	21	-	90	71
	C	B14 C80	70	45°	4 x Ø 5,5	60	14	24	40	15	64	80	65
	D	B5 / B14 C100	80	0°	4 x Ø 6,5	60	12	18	34	3	-	100	53
	E	B5 C120	100	45°	4 x M6x12	80	19	20	40	15	96	120	65
AXC80ZG/AG	A	B5 C160	130	45°	4 x M8x16	110	19	25	52	15	120	150	74
	B	B5 C120	100	45°	4 x M6x12	80	19	25	50	12	90	110	71
	C	B5 C120	100	45°	4 x M6x15	80	14	20	40	3	83	110	62
	D	LP70	62	0°	4 x Ø 5,5	52	16	16	36	8	82	100	66
	E	LP90	80	0°	4 x Ø 6,5	68	22	25	52	22	80	90	81
	F	B14 C80	70	45°	4 x Ø 6,5	60	19	20	40	11	80	110	70
AXC120ZG/AG	A	B5 C120	100	45°	4 x M6x18	80	19	30	50(60)	7	120	150	72(91)
	B	B5 C160	130	45°	4 x M6x18	80	24	30	60	18	-	160	83
	C	B5 C200	165	45°	4 x M10x20	130	19	20	40	1	-	200	66
AXDL110	A	B5 C120	80	45°	4 x M6x10	100	14	20	47,5	10	82	110	42,5
	B	B5 C160	110	45°	4 x M8x15	130	14	20	46	8,5	116	160	41
	C	LP070	62	0°	4 x Ø5,5	52	14	20	45,5	8	80	110	40,5
	D	LP050	44	0°	4 x Ø4,5	35	14	20	45,5	8	80	110	40,5
	E	CP060	52	45°	4 x Ø5,5	40	14	20	45,5	8	80	110	40,5
	F	B14 C80	70	45°	4 x Ø6,6	60	20	25	59,5	22	82	110	54,5
AXDL160	A	B5 C120	80	45°	4 x M6x15	100	14	20	43	0	86	120	22,5
	B	LP070	62	0°	4 x Ø5,5	52	14	25	51,5	8,5	78	106	31
	C	LP090	80	0°	4 x Ø6,6	68	14	25	54	11	100	135	33,5
	D	B14 C80	70	45°	4 x Ø6,6	60	14	20	49	6	86	120	28,5
	E	B5 C160	130	45°	4 x M8x18	110	19	30	60	17	120	150	39,5
AXDL240	A	B5 C120	80	45°	4 x M6x29	100	14	20	43	1	96	120	11
	B	B5 C120	80	45°	4 x M6	100	25	25	53	11	96	120	21
	C	TR105	85	45°	4 x Ø9	70	25	30	65,5	23,5	110	144	33,5
	E	B5 C160	110	45°	4 x M8x18	130	25	30	62	20	115	150	30

Please use the ID number to label the desired drive adaptation in the order description.
ID number X: special size or all dimensions not listed.



I Coupling cone for screw-type drive

In this variation, the drive is connected to the linear axis via a coupling cone. The power transmission is through an elastomer coupling insert. Motors with a plain shaft (friction-lock connections) and shafts with feather key (non-positive and interlocking connections).

- Drive adaptation **AXC40-120**

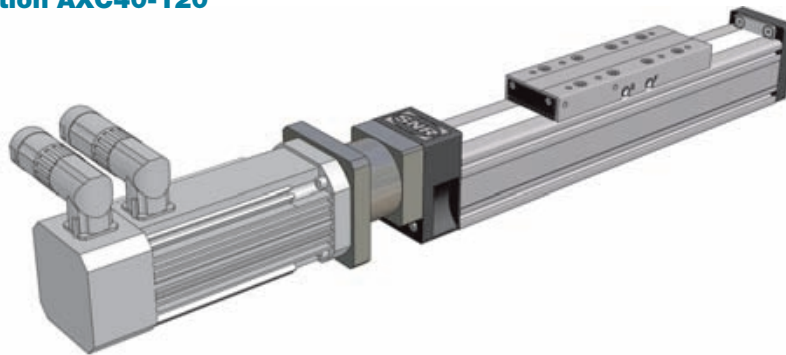

- Drive adaptation **AXLT155-455**

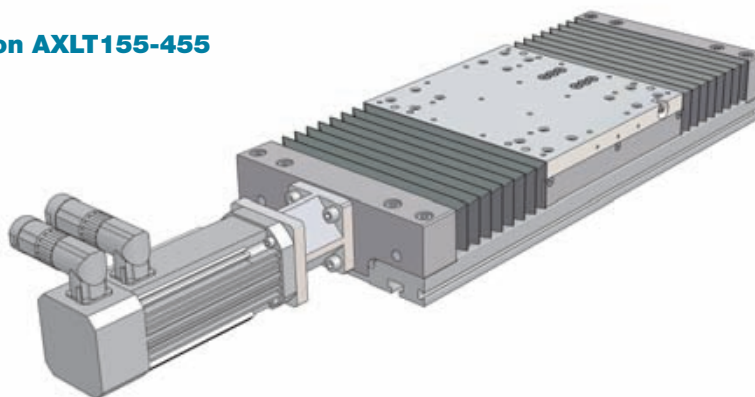

- Drive adaptation **AXDL110-240**

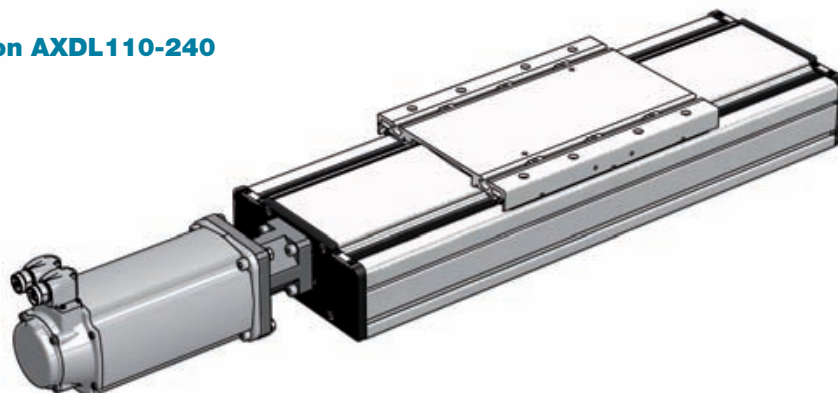

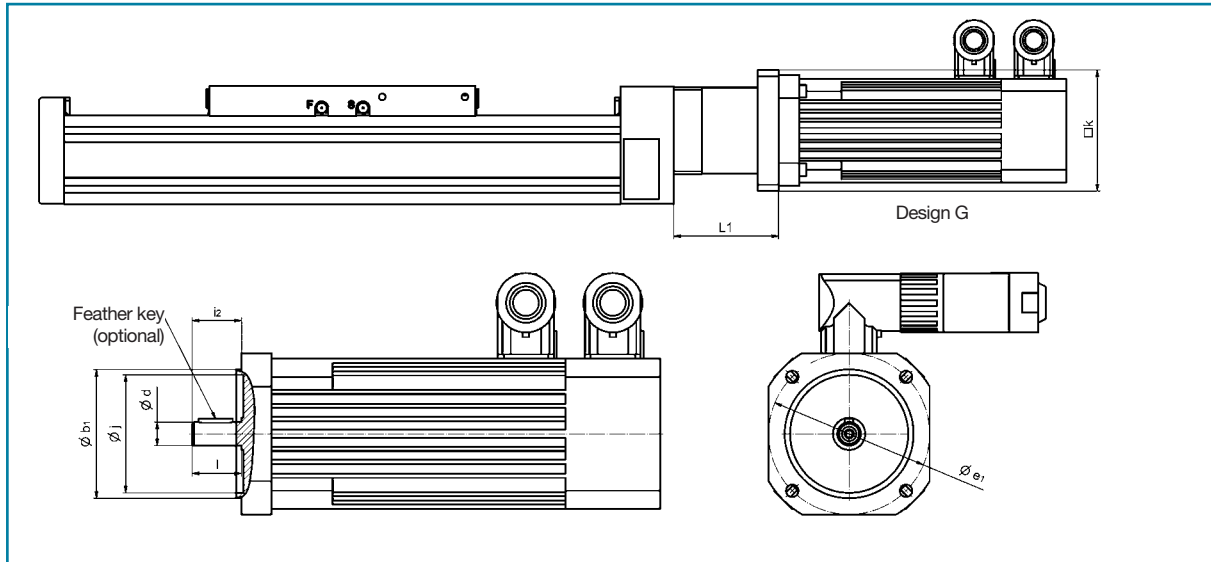

Linear axis	Motor model	e1 min.	e1 max.	b1 min.	b1 max.	d min.	d max.	i2 max.	i2-l max.	k	L1	max. drive torque
AXC40S	B5 / B14	45	63	35*	50	5	14	30	7	55	47	7,5 Nm
AXC60S	B5 (B14)	63 (75)	100	50*	80	9	19**	40	3	82	71	10 Nm
	B5	115	130	95	95	19	20	40	15	110	84	10 Nm
	B5	130	130	110	110	24	24	50	25	120	93	10 Nm
AXDL110	B5 (B14)	50 (70)	75	40	60	9	19**	40	3	60	72	10 Nm
AXLT155	B5 / B14	55	100	34*	80	5	14	30	7	85	71	10 Nm
AXC80/ AXDL160/ AXLT225	B5 / B14	63	100	50	80	9	19**	40	3	82	76	17 Nm
	B5	115	130	95	110	19	20	40	15	110	88	17 Nm
	B5	130	130	110	110	24	24	50	25	120	98	17 Nm
AXC120 / AXDL240 / AXLT325	B5 / B14	75	130	60*	110	14	24**	50	3	112	89	60 Nm
AXLT455	B5 / B14	100	165	80*	130	19	25	50	8	140	105	160 Nm
	B5 / B14	130	165	110	130	28	32	60	23	155	120	160 Nm
	B5 / B14	215	215	180	180	38	38	80	45	192	142	160 Nm

* Motors with smaller centering can also be used. The centering is then effected via the coupling.

** For motors with a feather key with maximum shaft length a shorter replacement feather key is provided.

I ID number drive adaptation

Centering b [mm]	35	40	50	60	60	70	70	80	80	95	95	110	110	130	130	180	180	180		
Diameter shaft [mm]	8	9	14	11	14	14	16	14	19	19	24	19	24	24	32	24	28	38		
ID number	Shaft without feather key		A	C	E	G	I	K		N	P	R	T	V	Y	A	C	E	G	I
	Shaft with feather key		B	D	F	H	J	L	M	O	Q	S	U	W	Z	B	D	F	H	J
Reference circle e [mm] ¹⁾	46	63	70/95	75		90		100	115	130		130		165						
Thread ¹⁾	M4	M4	M4/M6	M5		M5		M6		M8		M8		M10						

¹⁾ Only if using a deflection belt drive following the limit size, see page 89.

Please use the ID number to label the desired drive adaptation in the order description.

ID number X: special size or all dimensions not listed.



I Deflection belt drive for screw-type drive

To be able to take best advantage of the existing space even in cramped installation spaces, we offer deflection belt drives for linear axes with screw-type drive as well as for the linear tables. The mounting position of the drive can then be adapted to the environmental conditions. Motors with a plain shaft or a shaft with feather key are used depending on the selected reduction ratio and the associated fastening variations.

- **AXLT with deflection**

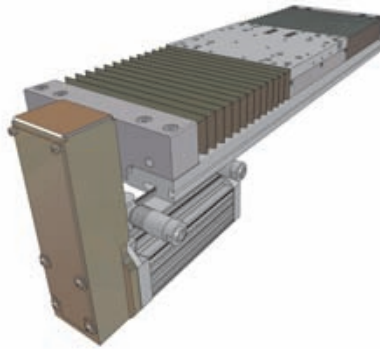

- **AXC with deflection belt drive**

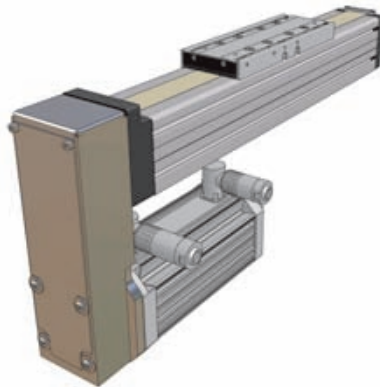

- **AXDL with deflection belt drive**

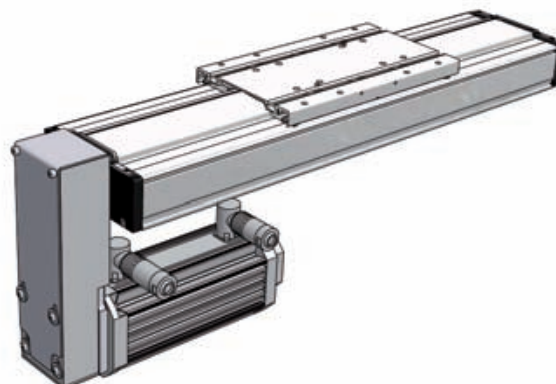

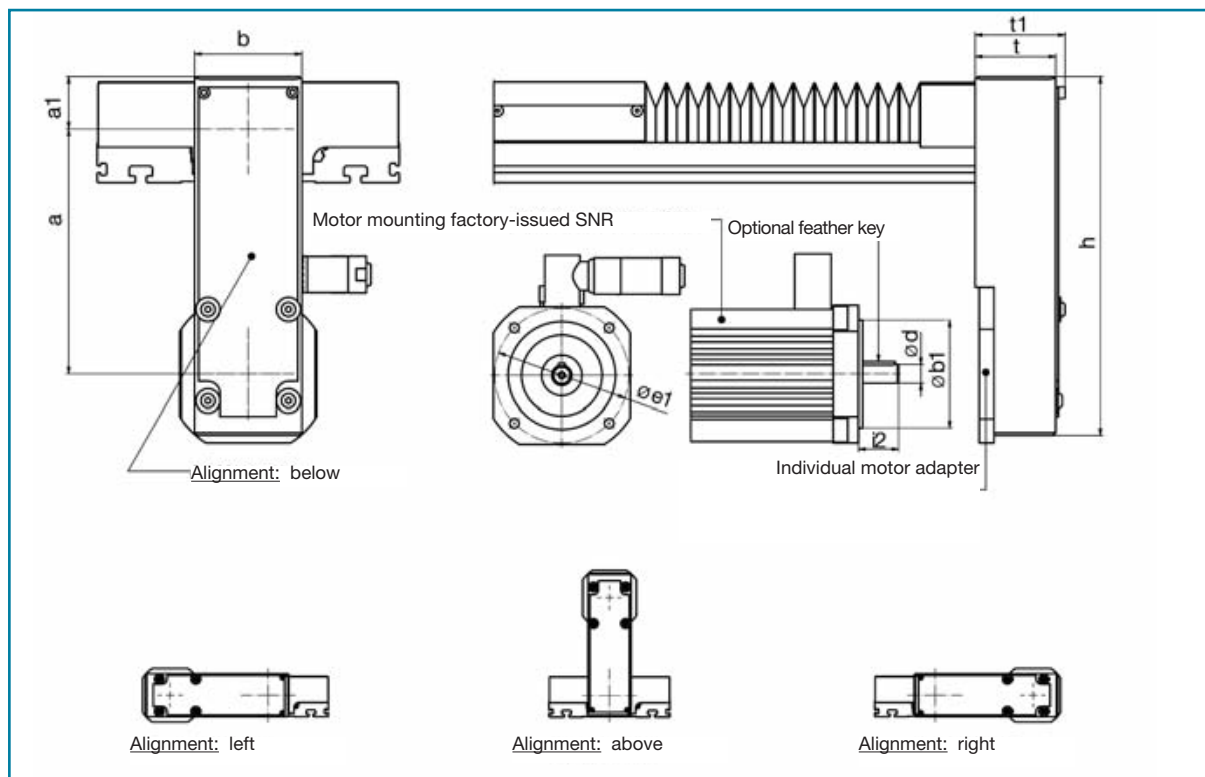

Linear axis	Available reduction ratios																	
	Minimum motor shaft diameter for fastening variations: Clamping set / feather key / adhesive joint																	
AXC60 / AXDL110 AXLT155	1			1,5			1,8			2,25								
	14	-	-	-	14	14	-	11	14	-	9	9						
AXC80 / AXDL160 AXLT225	1			1,25			1,5			2			2,5					
	16	24	24	14	19	24	10	16	19	-	12	14	-	9	11			
AXC120 / AXDL240 AXLT325	1			1,6			2			2,4			3,2			4		
	24	-	-	14	24	24	11	19	24	-	14	24	-	11	14	-	-	11
AXLT455	1			1,25			1,6			2								
	28	-	-	28	-	-	28	-	-	19	28	28						
Linear axis	Motor size limits (min / max)					Dimensions												
	$\varnothing b_1$	$\varnothing e_1$	i_2	Model	a	a ₁	b	h	t	t ₁								
AXC60	50* 60	63 75	20 30	B5	106 ± 6	35	60	197	40	45								
AXLT155 / AXDL110	40* 60	63 75	20 30	B5	140,5 ± 2	31,5	60	216	40	45								
AXC80 / AXLT225	50* 80	63 100	20 50	B5	185 ± 2,5	39	80	267	60	67								
AXC120 / AXLT325	60* 110	75 130	30 50	B5 / B14	249,5 ± 5,5	57	100	407	60	67								
AXLT455	80* 130	100 165	30 60	B5 / B14	354 ± 5	89	180	565	80	89								

** Motors with smaller centering ($\varnothing b_1$) can also be used. In this case the centering through the motor adapter is not applicable.
ID number drive adaptation: see page 87



I Exterior size/plug-in shaft for AXC_Z/AXDL_Z

In the event of a drive adaptation by the user, the designated mounting side must be indicated when ordering, since the axis profile for an optimal seat of the drive adapter is determined. The corresponding sliding blocks for drive fastening are contained in the delivery kit.

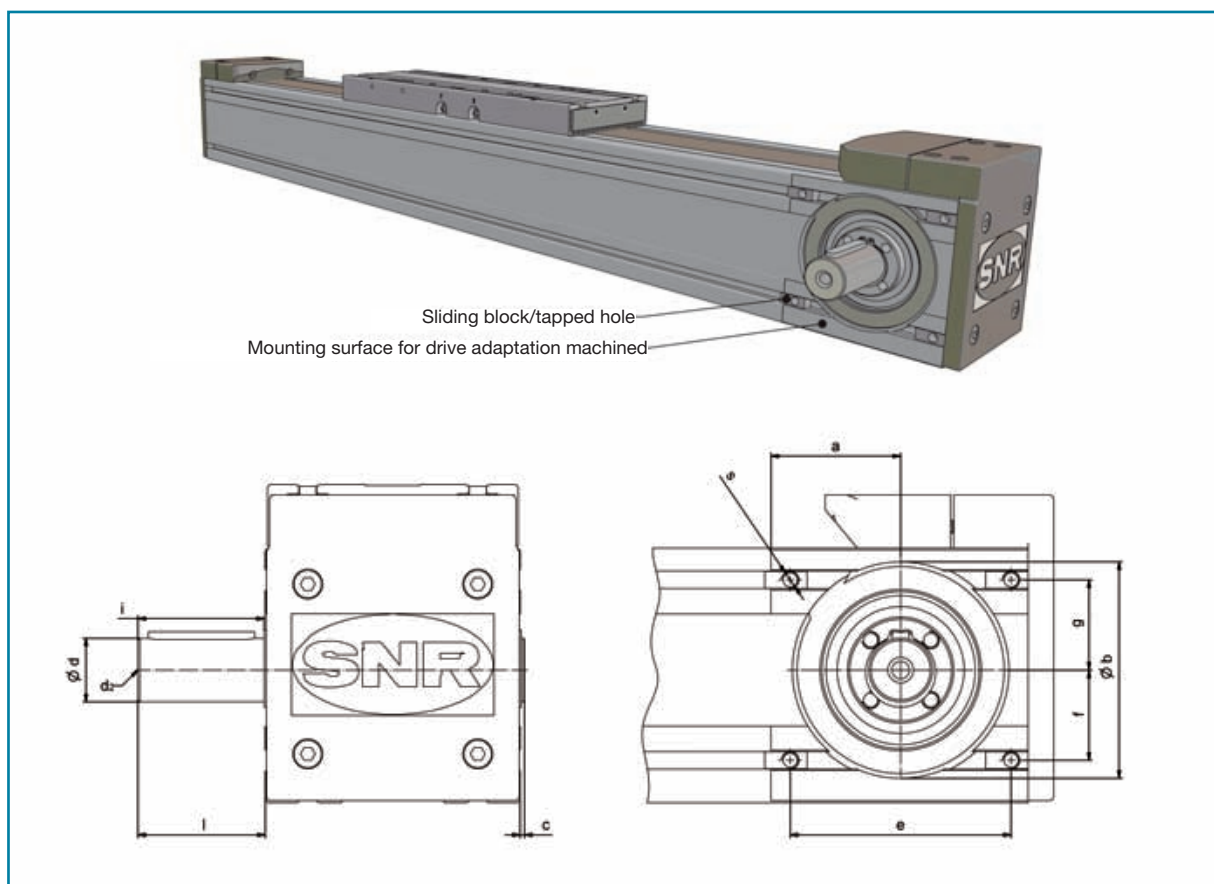

Linear axis	a	b	c	d h6	d2	e	f	g	i	l	s
AXC40Z	23	26H7x1	1	10	M4x7	34	9,9	8,1	29,5	30	M3x5
AXC60Z / A	34	47H7x1	1	14	M5x8	54	22,5	17,5	30,0	30	M5x6
AXC80Z / A	42	68H7x2	2	20	M6x10	72	23,0	20,5	39,3	40	M5x9
AXC120Z / A	61	102H8x2				104	42,5	42,5			M8x12
AXC120A ¹⁾	Ø 162	110H8x3,5				Ø 130	-	-			M8x13
AXDL110Z ¹⁾	-	60H8x19	-	16	M5x8	Ø 68	-	-	55,5	30	M5x10
AXDL160Z	-	75H8x41	-	25	M10x17	66	25,0	25,0	92,3	50	M6x15
AXDL240Z ¹⁾	-	90H8x53	-	30	M10x17	Ø 100	-	-	113,5	60	M6x18

¹⁾ For description see diagrams on pages 40, 44 and 52.

I Coupling and connecting shaft

Parallel axes can be coupled via a connecting shaft to transfer the torque of the motor-driven axis to the second axis.

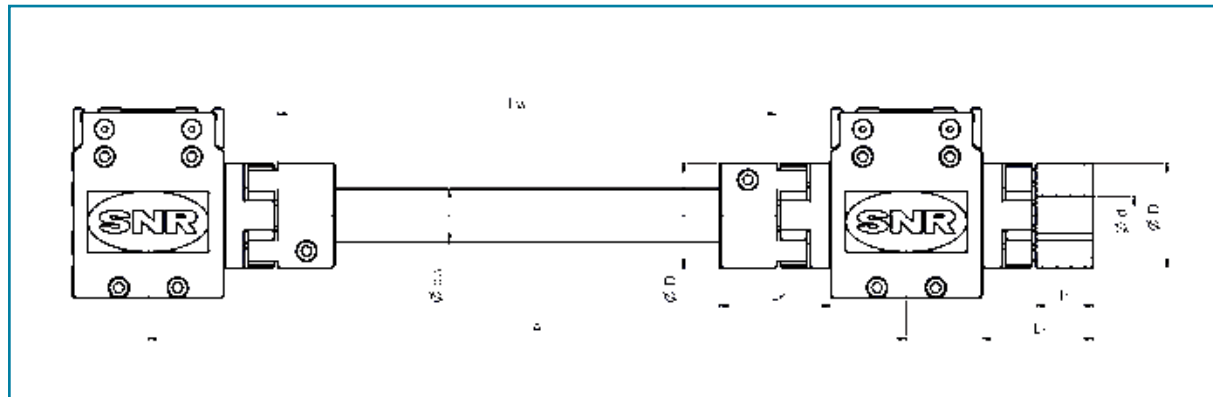
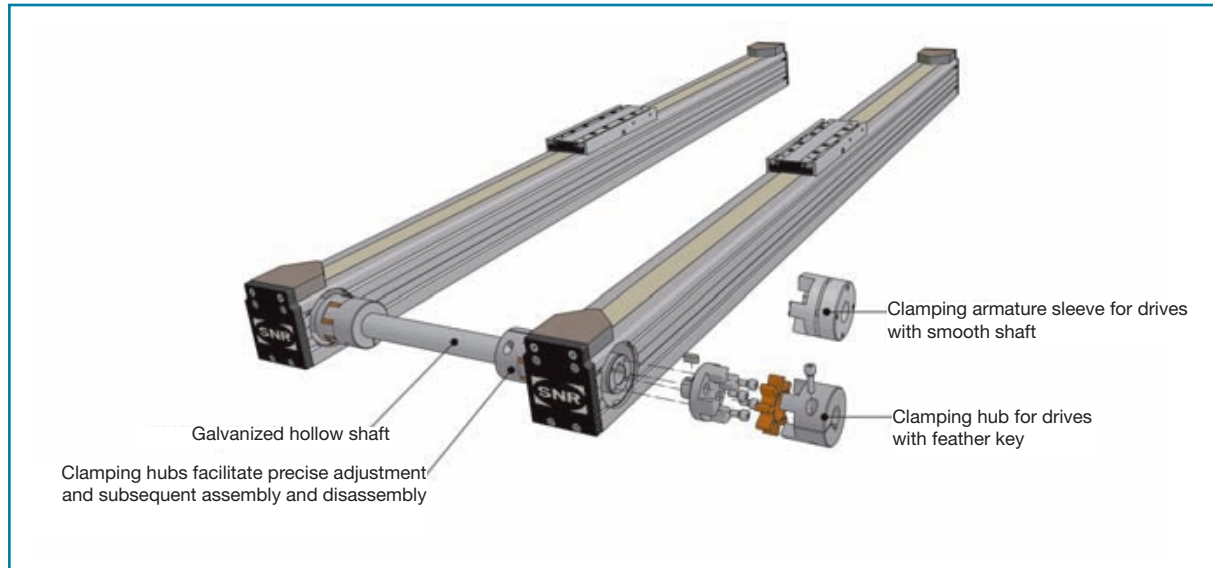

Linear axis	Dimensions							Clamping hub			C. armature sleeve		
	dw	Lw	A min. ¹⁾	A DKM ²⁾	D	LK	l1	d min.	d max.	TA ³⁾ [Nm]	d min.	d max.	TA ³⁾ [Nm]
AXC40ZK	14x2	A - 79	125	87 ⁺²	30	31	11	8	16	1,34	-	-	-
						38	19	-	-	-	10	14	1,34
AXC60-..K	22x2	A - 110	188	120 ⁺²	40	50	25	12	24	10,5	10	20	3
AXC80-..K	28x2,5	A - 137	230	154(160) ⁺³	55	59	30	12	28	10,5	15	28	6
AXC120-..K	38x4	A - 180	285	198 ⁺³	65	65	35	20	38	25	18	38	6
AXC120-..P.K		A - 140	245	158 ⁺³		25	-				-	-	
AXDL110	Connecting not available				55	32,5	30	12	28	10,5	15	28	6
AXDL160	Connecting not available				65	22,5	35	20	38	25	18	38	6
AXDL240	Connecting not available				65	10	35	20	38	25	18	38	6

1) With possibility of removal without disassembly of the linear axes.

2) DKM = special design with double output middle piece.

3) Tightening torque.

Switches



I Switch add-on on AXC/AXLT/AXDL

Mechanical switches in different protection classes as well as inductive proximity switches with the conventional output circuits are available for position detection depending on requirements. In an emergency, to disconnect the drive before the mechanical stop buffer shock absorber is reached, a mechanically activated switch is usually used. These can also be combined with external inductive proximity switches to set additional switching points for reference runs for example. A set of mechanical limit switches consists of two switches with fastening elements and a cam switch.

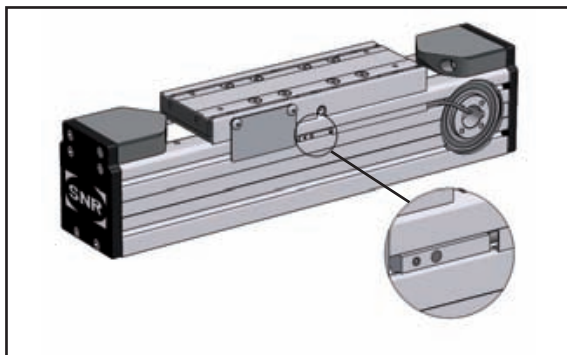
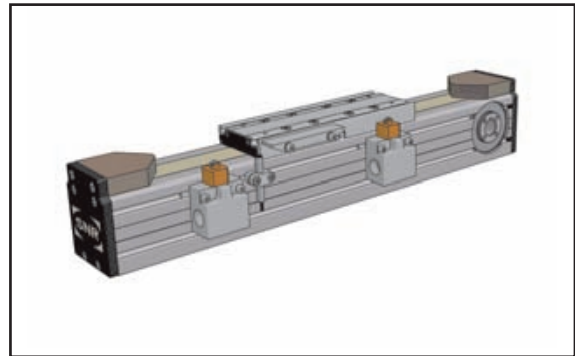

Our inductive proximity switches for groove installation are the most compact variant. They lock flush with the surface of the aluminium profile of the axis and form almost no disruption to the surface. Moreover, a cover profile is attached to the groove to secure the position of the cable in the groove (see page 111). The switches are obtainable as PNP break contacts/make contacts or NPN break contacts. A set of inductive proximity switches consists of two switches with fastening elements and a cam switch. All switches are already factory-installed.

I Cable connections to proximity switches

The cables from the AXC initiators to the drive are set in a groove. The cable length is designed to leave at least 0.5 m free. Should this prove not to be the case with the maximum cable length available, the cable is routed from the opposite side. In the type AXC60 only two AXC initiators can be installed on each side.

The cables from initiators I2 to the drive are set in a groove, except in the AXC40. The cable length is designed to leave at least 0.5 m free. Should this prove not to be the case with the cable length available, the cable is routed from the opposite side. In type AXDL110Z the cables are always conducted to the deflection side. In type AXLT155 the cables are always conducted to the drive side.

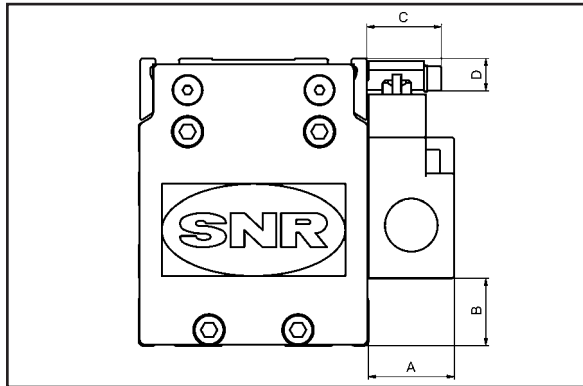

Mounting option 1

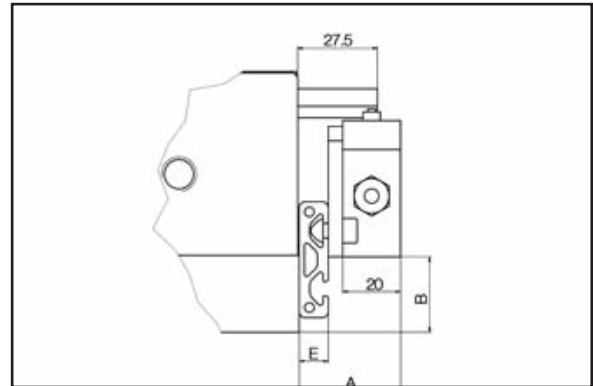

Mounting option 2

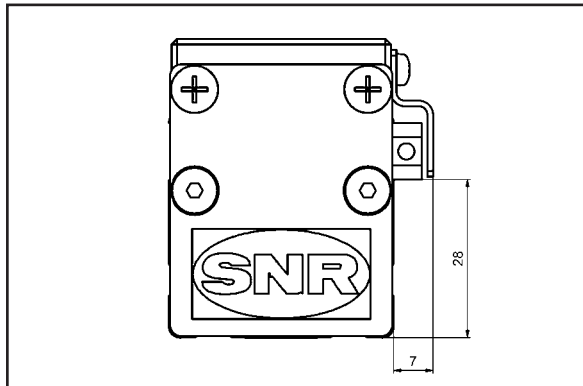

Mounting option 3

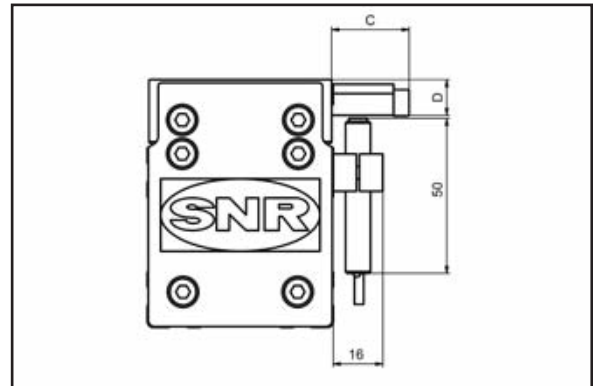

Mounting option 4

Linear axis	Switch	A	B	C	D	E	Mounting option
AXC40	I1	7	28	-	-	-	3
AXC60	M2	22	19,5	25	11,5	-	1
	M3	20	12,5	18	19	-	1
	I2	-	-	like M2 / M3		-	4
AXC60A	M1	30	9,5	18	55	-	1
AXC80	M1	30	25,5	26	11	-	1
	I2	-	-	26	11	-	4
AXC120	M1	30	64,5	26	20	-	1
	I2	-	-	26	11	-	4
AXLT155	M3	25	1	-	-	-	2
AXLT225	M3	25	11	-	-	-	2
AXLT325	M3	35	26	-	-	10	2
AXLT455	M3	34	39,5	-	-	14	2
AXDL110	M2	31	7	24	9,3	10	2
AXDL160	M1	30	9,5	15	8,5	-	1
AXDL240	M1	30	22	15	33	-	1



• **AXC 40**

Inductive switches (I1)

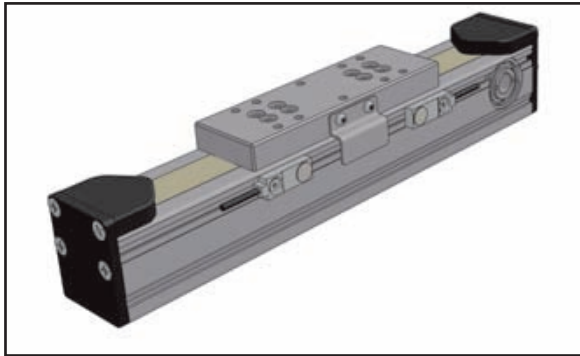

• **AXC60**

Inductive switches (AXC initiator)

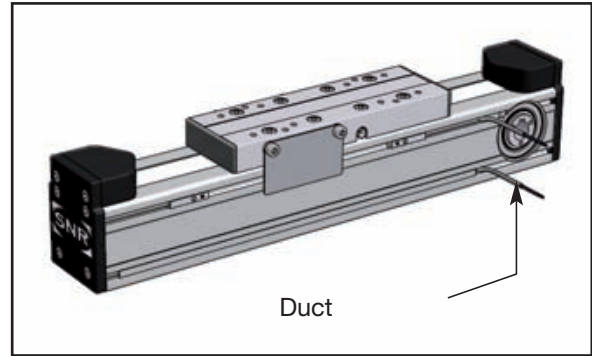

• **AXC60**

Mechanical and inductive switches

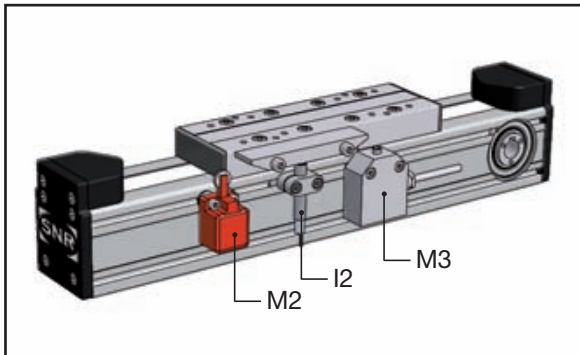

• **AXC80**

Inductive switches (AXC initiator)

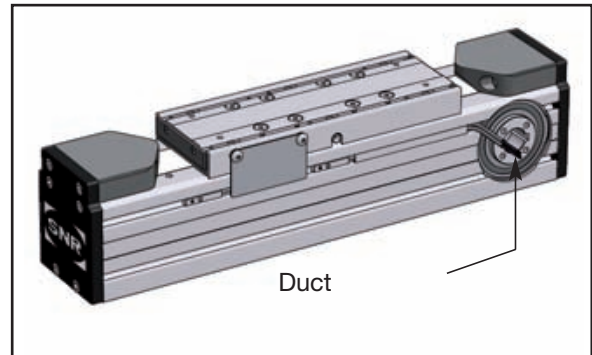

• **AXC80**

Mechanical and inductive switches

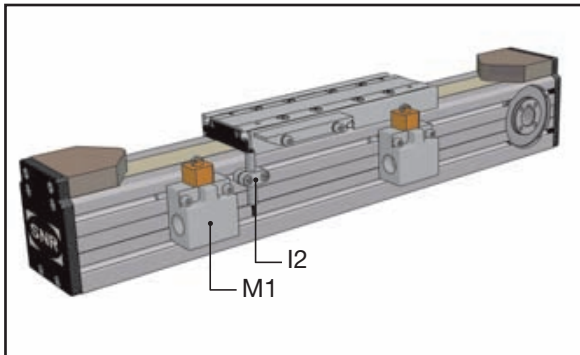

• **AXC120**

Mechanical and/or inductive switches

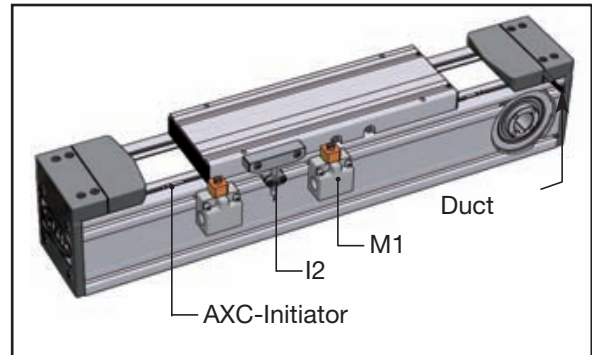

• **AXC_A**

Carriage moves

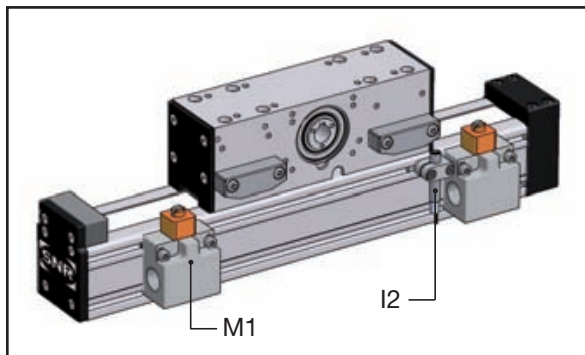

Section moves

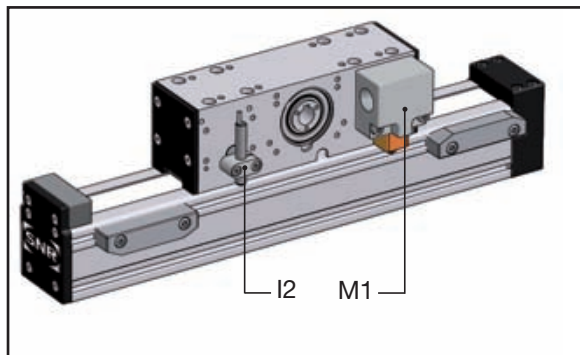

• **AXDL110**

Mechanical and inductive switches

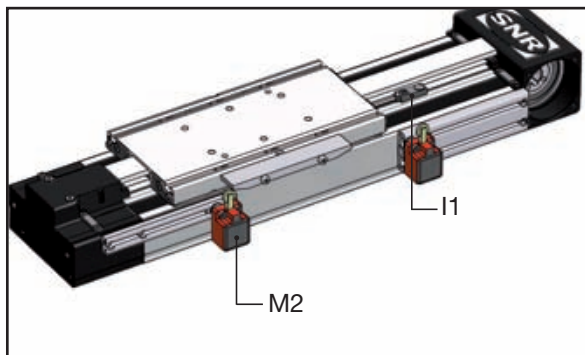

• **AXDL160/240**

Mechanical and inductive switches

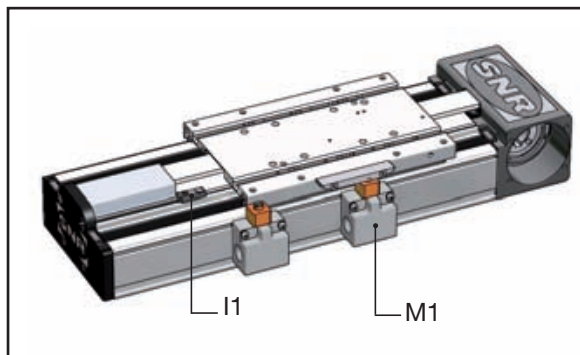

• **AXLT**

Mechanical and inductive switches

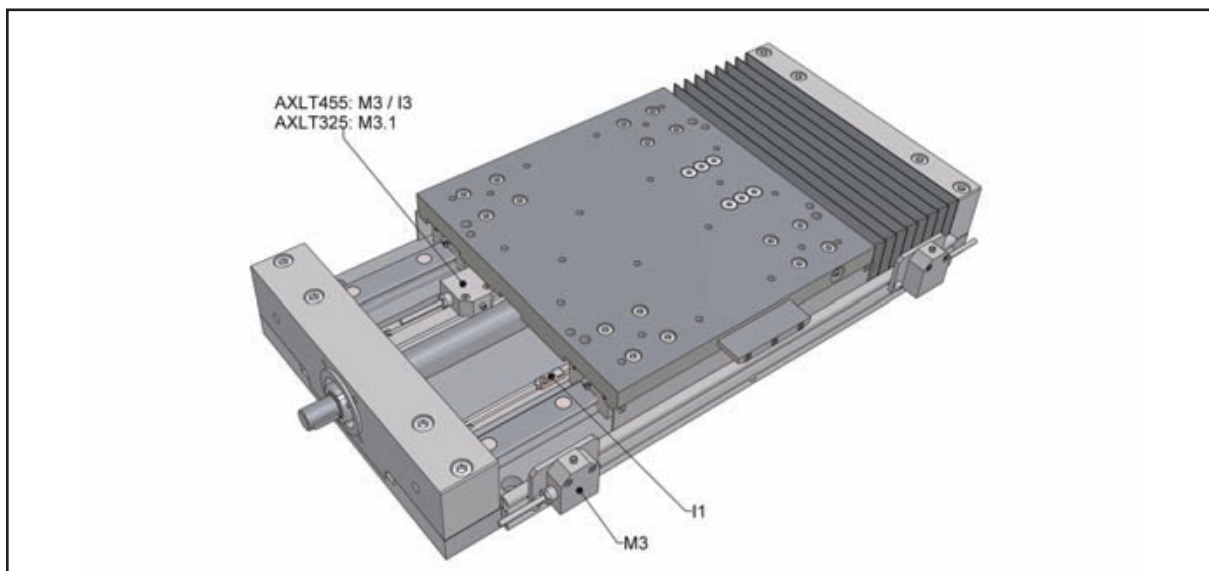



I Fitting of switches to AXS modules

All AXS series linear axes are available with mechanical switches as standard. Inductive proximity switches are also available for the AXS280Z portal axis.

- Lifting axes **AXS200M to AXS280M** and telescopic axis **AXS120**

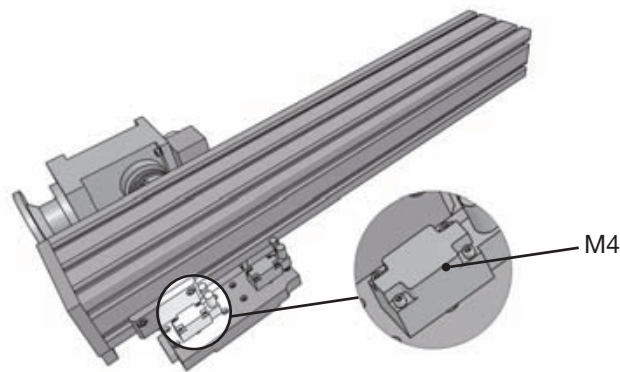

- Portal axis **AXS280Z**

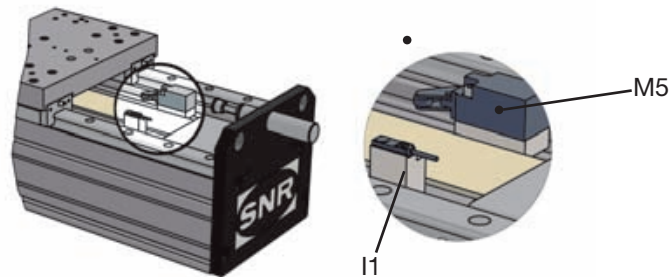

- Portal axes

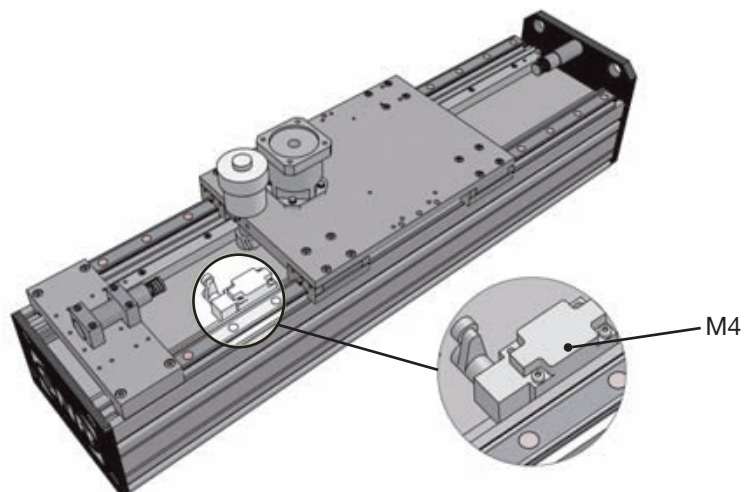

I Sensor box on AXC / AXLT

It is easy to connect the cables professionally using sensor boxes, which are available as standard. All switching signals are channeled through here. Connection to the signal-processing control unit is rapidly set up with the help of pre-assembled lines.

Depending on the number of switches required, either a 2x distributor can be used or a sensor box to which four or more switches can be connected. Both designs have an IP67 protection rating and are supplied completely wired, as shown in the picture. An 8-pole plug connection with M12 thread for the sensor box or a 5-pole plug connection with M8 thread for the 2x distributor is available for the connection to the signal-processing control unit.

• 2x distributor

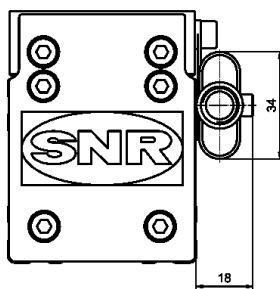

• Sensor box for 4 switches

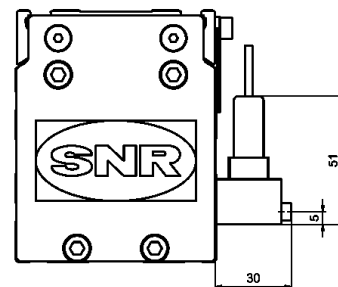
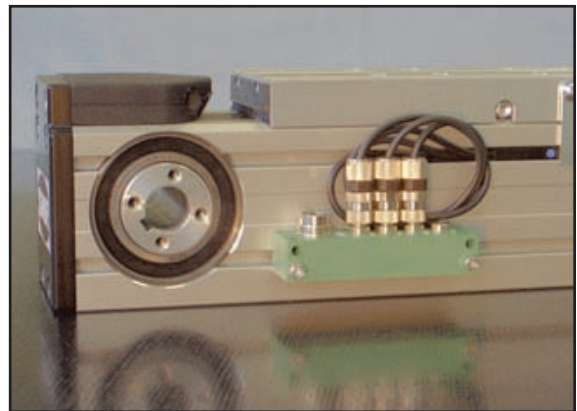

To prevent unwanted projections, the sensor box in type AXC120-S and AXLT325 can also be mounted under the motor adapter as a space-saving measure.

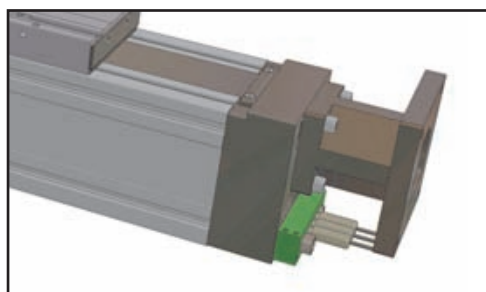



I Technical data of switches

• Mechanical safety limit switch

	Service life	Housing material	Screw fitting	Protection class
Switch M1 / M4 / M5 AXC60A AXC80/120 AXDL160/240 AXS	30x10 ⁶ Contacts	Plastic	M20x1,5 Cross-section area: 0,5...2,5mm ²	IP67
Switch M2 AXC60Z/S AXDL110	30x10 ⁶ Contacts	Plastic	Threaded terminal ends: 4xM3,5 Cross-section area: 0,5...1,5mm ²	IP30
Switch M3 AXC60Z/S AXLT155 - AXLT455	10x10 ⁶ Contacts	Metal	Threaded terminal ends Cross-section area: max. 1,5mm ²	IP67
Switch M3.1 (soldering connection) AXLT325	10x10 ⁶ Contacts	Metal	Soldering connection Cross-section area: max. 1,5mm ²	IP67

Switch element: snap switch (automatic separation)/1x break contact and 1x make contact.

• Inductive proximity switch

	Connection voltage	Max. load power	Indexing précision	Cable length	Protection class
Switch I1 PNP-NO (make contact) NPN/PNP-NC (break contact) AXC40 AXDL AXLT AXS	10...30 V DC	100 mA	≤ 10% of the switch distance	5m	IP67
AXC- Initiator PNP-NC (B.contact)/NO (M.contact) NPN-NC AXC60 - AXC120	10...30 V DC	100 mA	≤ 2% of the switch distance	10m	IP67
Switch I2 AXC60 - AXC120	12...30 V DC	100 mA	≤ 5% of the switch distance	2m	IP67

• **Combination options for fitting of switches**

Encoding	Number of switches						Mountable on the axis													
	Mechanical switch		Inductive proximity switch			I1 -- I2			AXC60A		AXC80A		AXC120A		AXDL		AXLT		AXS	
			AXC initiator						Carriage moves	Section moves	Carriage moves	Section moves	Carriage moves	Section moves					Portal axes	Lifting axes
	M1, M2, M4, M5	M3, M3.1	PNP-NC 10m cable	PNP-NO 10m cable	NPN-NC 3m cable	AXC40Z AXC40S	AXC60Z AXC60S	AXC80Z AXC80S							AXC120Z AXC120S					
00							X	X	X	X	X	X	X	X	X	X	X	X	X	
01	1						O	X	X	X	X	X	X	X	X	X	O	X	X	
02	2						O	X	X	X ¹⁾	X	X	X	X	X	X	O	X	X	
03	2					1	O	X	X	O	X	X	O	X	X	O	X ²⁾	O	X	O
04	2					1	O	X	X	O	X	X	O	X	X	O	X ²⁾	O	X	O
05		1					O	X	O	O	O	O	O	O	O	O	O	X	O	O
06		2					O	X	O	O	O	O	O	O	O	O	O	X	O	O
07		2				1	O	X	O	O	O	O	O	O	O	O	O	X ³⁾	O	O
08		2				1	O	X	O	O	O	O	O	O	O	O	O	X ³⁾	O	O
12			1				O	X	X	O	X	X	O	X	O	O	O	O	O	O
13			2				O	X	X	O	X	X	O	X	O	O	O	O	O	O
14			3				O	O	O	O	X	X	O	X	O	O	O	O	O	O
18				1			O	X	X	O	X	X	O	X	O	O	O	O	O	O
19				2			O	X	X	O	X	X	O	X	O	O	O	O	O	O
20				3			O	O	O	O	X	X	O	X	O	O	O	O	O	O
21					1		O	X	X	O	X	X	O	X	O	O	O	O	O	O
22					2		O	X	X	O	X	X	O	X	O	O	O	O	O	O
23					3		O	O	O	O	X	X	O	X	O	O	O	O	O	O
24							O	O	O	O	X	X	O	X	O	O	O	O	O	O
25			2	1			O	O	O	O	X	X	O	X	O	O	O	O	O	O
26					1		X	X	X	X	X	X	X	X	X	X	X ²⁾	X ³⁾	X	X
27					2		X	X	X	X	X	X	X	X	X	X	X ²⁾	X ³⁾	X	X
28					3		X	X	X	O	X	X	O	X	X	O	X ²⁾	X ³⁾	X	O
29						1	X	X	X	X	X	X	X	X	X	X	X ²⁾	X ³⁾	X	X
30						2	X	X	X	X	X	X	X	X	X	X	X ²⁾	X ³⁾	X	X
31						3	X	X	X	O	X	X	O	X	X	O	X ²⁾	X ³⁾	X	O
32						1	X	X	X	X	X	X	X	X	X	X	X ²⁾	X ³⁾	X	X
33						2	X	X	X	X	X	X	X	X	X	X	X ²⁾	X ³⁾	X	X
34						3	X	X	X	O	X	X	O	X	X	O	X ²⁾	X ³⁾	X	O
35					2	1	X	X	X	O	X	X	O	X	X	O	X ²⁾	X ³⁾	X	O

* X Possible variants

O Not possible

1) Not possible in connection with the standard connection. Please choose 01 here on both sides (the combinations 01 + 26 / 29 / 32 are also possible).

2) Initiator mounted on the upper right side; in the order description, always take into consideration the "fitting of switches to the left", in position 9.

3) Initiator mounted inwards to the left; in the order description, always take into consideration the "fitting of switches to the left", in position 9.

Other switch combinations are designated in the order description with XX and described in plain language.

Attachments and fasteners



There is a range of optimally coordinated fixing elements available for the fastening of the different linear modules. Sliding blocks, fastening strips and adapters offer the most diverse possibilities to bolt down our modules on mounting surfaces or with each other. In addition, we also offer gantry support legs matched to the linear axes and axle systems to complete the range.

The distance of the fixing points depends on the load and the desired straightness as well as rigidity.

I Fastening strips for AXC / AXDL

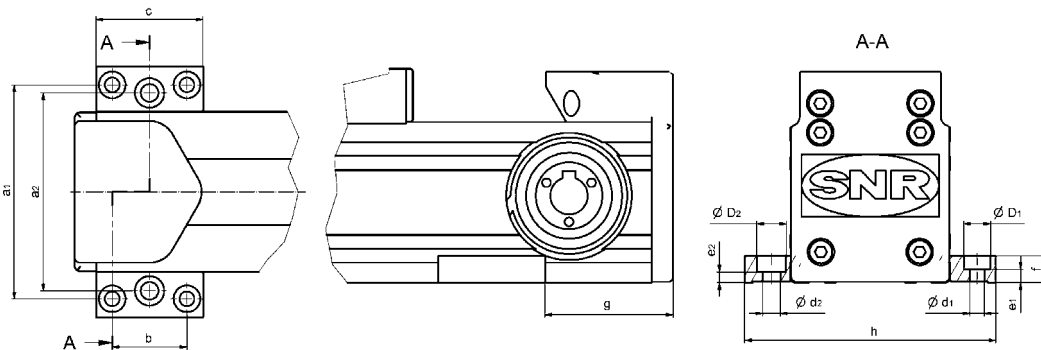
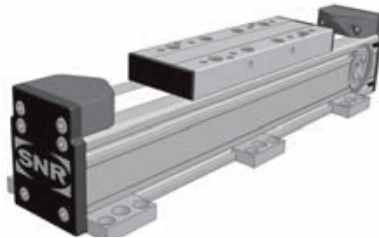

Linear axis	Article description	a1	a2	b	c	d1	D1	e1	d2	D2	e2	f	g ¹⁾	h
AXC40	AXC40 fastening strip	55	-	28	40	5,5	10	7	-	-	-	13	38 ²⁾	66
AXC60 ³⁾	AXC60 fastening strip	80	74	28	40	5,5	10	5	6,6	11	4	10	48	94
AXC80	AXC80 fastening strip	94	-	50	70	6,6	11	14	-	-	-	20	76	108
AXC120 ⁴⁾	AXC120 fastening strip	136	-	60	78	9	15	11,5	-	-	-	22	105	160
	Fastening strip 2	140	-	40	80	9	15	13	-	-	-	22	105	160
	Fastening strip 3	140	140	80	120	9	15	13	9	15	13	22	105	160
AXDL110	AXDL110 fastening strip	126	-	30	47	5,5	9	3,5	-	-	-	7	69	140
AXDL160	AXDL160 fastening strip	174	-	50	68	6,6	11	3,5	-	-	-	9	88	188
AXDL240 ⁴⁾	AXC120 fastening strip	256	-	60	78	9	15	11,5	-	-	-	22	108	280
	Fastening strip 2	260	-	40	80	9	15	13	-	-	-	22	108	280
	Fastening strip 3	260	260	80	120	9	15	13	9	15	13	22	108	280

1) If applicable: size k2 of drive adapter or gearbox, however follow at least size a of the drive-side machining!

2) With mounted coupling.

3) Furthermore, suitable for size 20 standard profiles.

4) Furthermore, suitable for size 40 standard profiles.

I Sliding blocks

Model E

- Standard sliding block
- St galvanized
- Can be swiveled into any position
- Fixed via spring-loaded ball



Model R

- For efficient part installation
- Zn galvanized
- Pre-mounted on the component and used in any position
- Locked by turning of screw



Model S

- Heavy-duty sliding block
- St galvanized
- Push in from profile end
- To groove width 8 fixed via spring-loaded ball

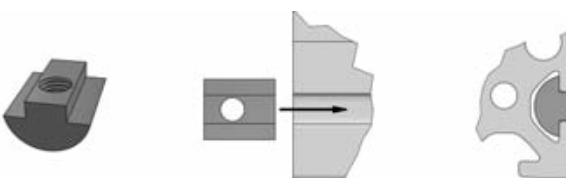

Linear axis	Sliding block designation	Model	s	L ¹⁾	L1 ¹⁾	TA [Nm] ²⁾	max. tensile force [N]
AXC40 AXC60	5 ST M3	E	M3	12	3	1,5	500
	5 ST M4	E	M4	12	4	3,0	500
	5 ST M5	E	M5	12	4	4,5	500
	5 Zn M3	R	M3	5	2,5	1,0	50
AXC80	6 ST M4	E	M4	17	5	4,0	1750
	6 ST M5	E	M5	17	5	8,0 ³⁾	1750
	6 ST M6	E	M6	17	5,5	14 ³⁾	1750
	6 Zn M4	R	M4	15	7,5	1,5	150
AXC120 AXLT155 AXLT225 AXS120T AXS160 AXS200 AXDL240	8 ST M4	E	M4	22	9	4,0	2500
	8 ST M6	E	M6	22	9	14 ³⁾	3500
	8 ST M8	E	M8	22	9	25	5000
	8 Zn M4	R	M4	19	9,5	1,5	250
	8 Zn M5	R	M5	19	9,5	1,5	250
	8 ST M5 adjustable	S	M5	22	9	8,0 ³⁾	2500
	8 ST M6 adjustable	S	M6	22	7	14 ³⁾	3500
	8 ST M8 adjustable	S	M8	20	7	34 ³⁾	5000
	AXS280	12 ST M6	S	M6	20	10	14 ³⁾
12 ST M8		S	M8	20	10	34 ³⁾	6000
12 ST M10		S	M10	35	11,5	46	10000
AXS230	DIN508-14 M8	S	M8	22	11	34 ³⁾	6000
AXS460	DIN508-14 M12	S	M12	22	11	85	10000

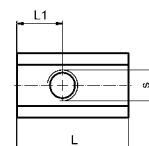

1) maximum values, different dimensions possible.

2) maximum tightening torque.

3) screws with strength category 10.9 are necessary in space utilization of the maximum tightening torques.

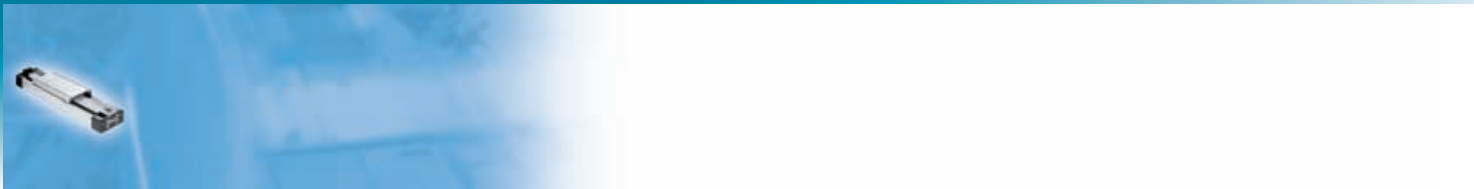

I Direct connection

We offer the user a lot of possibilities to connect the axes in a multi-axis system. Different adapter models are available. The connection kits contain all other necessary connection items (example: adapter plates, screws, etc.)

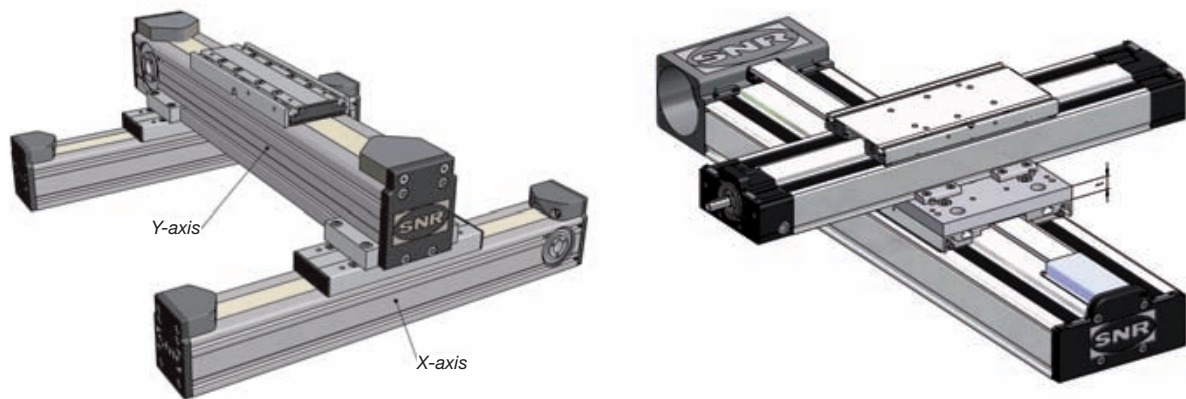

X-axis	Y-axis						
	AXC40	AXC60	AXC80	AXC120	AXDL110	AXDL160	AXDL240
AXC40	AXC direct connection 40-40	AXC direct connection 40-60					
AXC60		2 x AXC direct connection 60-60	AXC direct connection 60-80	AXC direct connection 60-120	AX direct connection 60-110 ⁴⁾		
AXC80				AXC direct connection 80-120		AX direct connection 80-160	AXC direct connection 80-120 (table 280)
AXC120				AXC direct connection 120-120			AXC direct connection 120-120
MB-profile raster 40		AXC direct connection 60-60 + 2 x slut nut 8 ST M6		2 x fixing strip 2(3) 4 (6) x M8x25 DIN 912 4 (6) x slut nut 8 ST M8			Fixing strip 2 (3)
MB-profile raster 50			AXC direct connection 60-80 + 4 x slut nut 8 ST M6			AXDL160 -fixing strip	
AXDL110	AX direct connection 110-40 ¹⁾	AX direct connection 110-60 ¹⁾			AXDL direct connection 110-110		
AXDL160 ²⁾		AX direct connection 160-60	AX direct connection 160-80		AXDL direct connection 160-110	AXDL direct connection 160-160	
AXDL240 ³⁾				AX direct connection 240-120		AXDL direct connection 240-160	AXDL direct connection 240-240

1) Distance plate t = 12 mm
2) Distance plate t = 15 mm

3) Distance plate t = 20 mm
4) Additional holes required on the tabletops of the X-axis

I Cross connection

Alignment using cylinder pins or stop angle

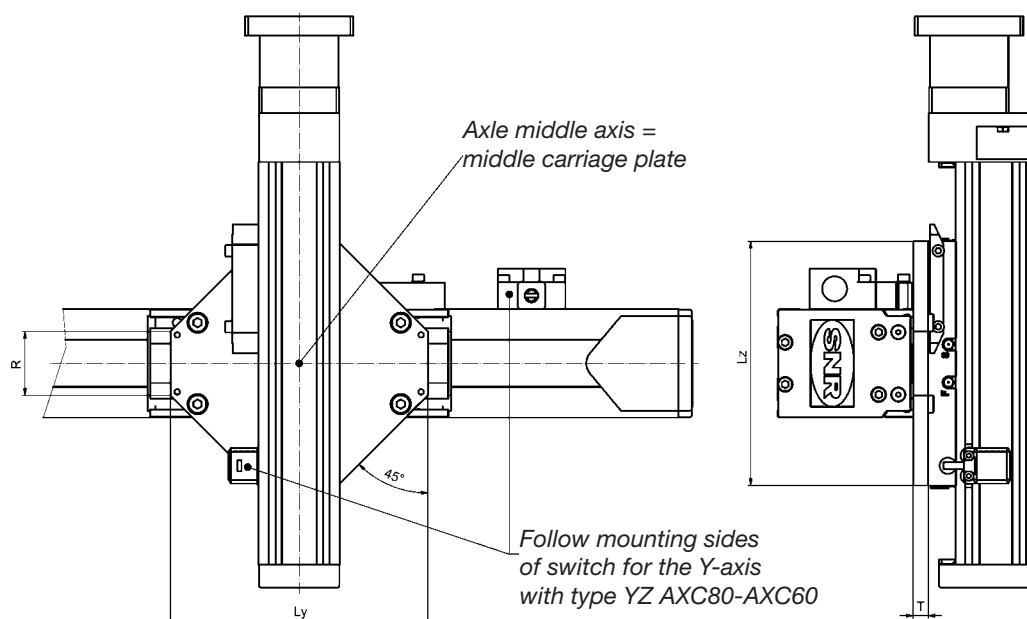
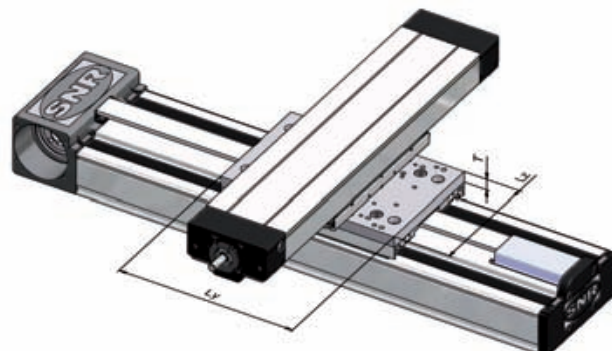
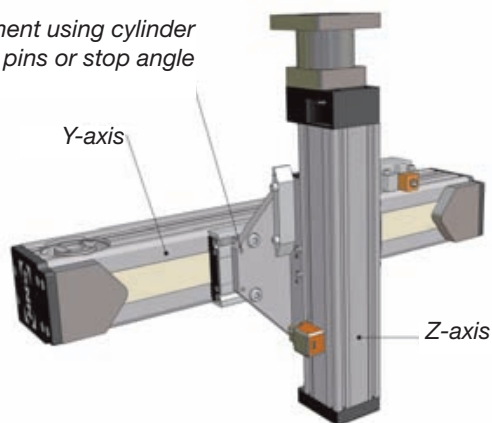

Y-axis	Z-axis	Ly	Lz	R	T	Order reference
AXC60	AXC40	90	90	58	10	AXC cross connection 60-40
AXC60	AXC60	90	90	58	12	AXC cross connection 60-60
AXC80	AXC60	190	180	47	11	AXC cross connection 80-60
AXC80	AXC80	220	220	77	15	AXC cross connection 80-80
AXC120	AXC80	280	220	116	20	AXC cross connection 120-80
AXC120	AXC120	280	280	116	20	AXC cross connection 120-120
AXDL110	AXC40	215	120	-	12	AX cross connection 110-40
AXDL110	AXC60	215	120	-	12	AX cross connection 110-60
AXDL160	AXC60	240	160	-	15	AX cross connection 160-60
AXDL160	AXC80	220	200	-	20	AX cross connection 160-80
AXDL240	AXC80	330	240	-	20	AX cross connection 240-80
AXDL240	AXC120	330	325	-	20	AX cross connection 240-120
AXDL110	AXDL110	215	120	-	12	AXDL cross connection 110-110
AXDL160	AXDL110	240	160	-	15	AXDL cross connection 160-110
AXDL160	AXDL160	240	160	-	15	AXDL cross connection 160-160
AXDL240	AXDL160	330	240	-	20	AXDL cross connection 240-160
AXDL240	AXDL240	330	240	-	20	AXDL cross connection 240-240



I Gantry connection

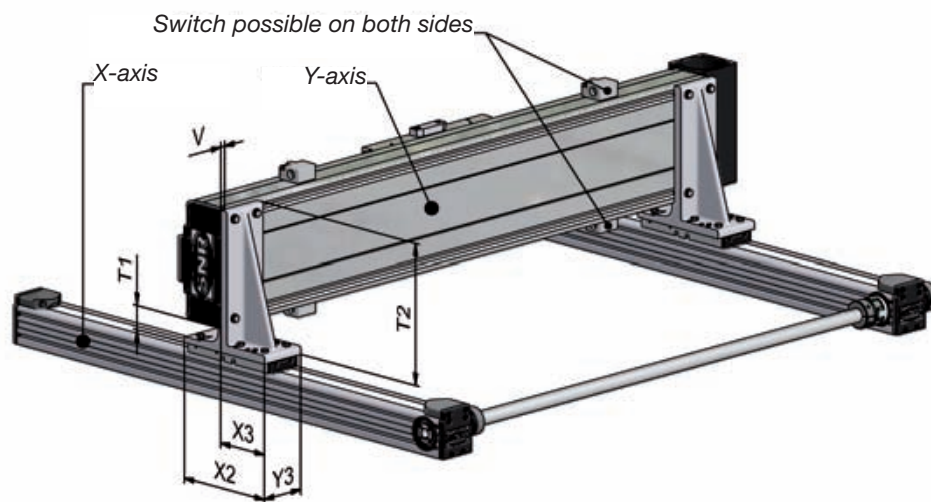
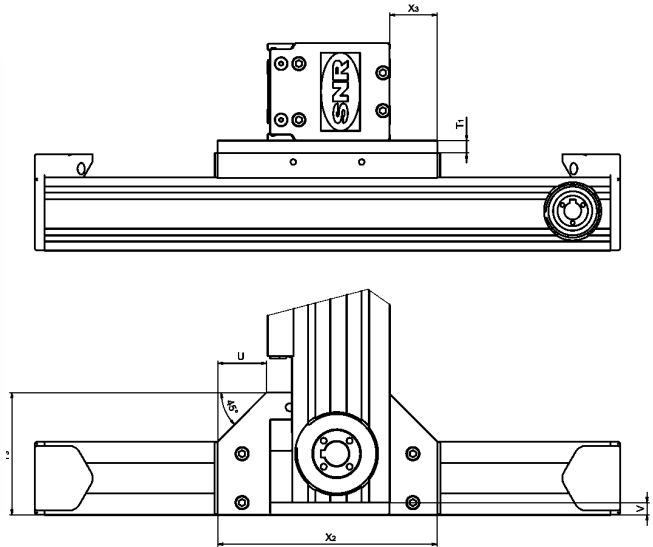
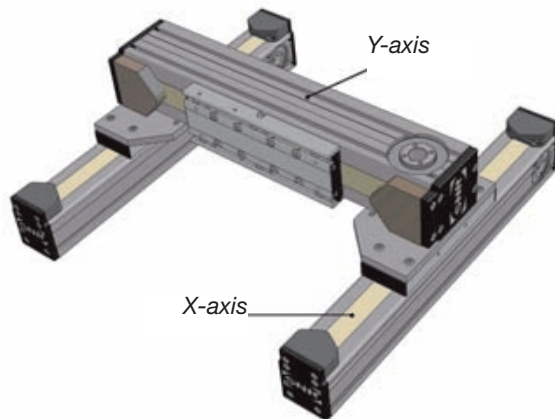

X-axis	Y-axis	T1	T2	U	V	X2	X3	Y3	Article description
AXC40	AXC60	8	-	20	-11	98	19	59	AXC gantry connection 40-60
AXC60	AXC80Z	10	-	40	10	180	39	100	AXC gantry connection 60-80
	AXC80S/A	-	-	22	22				
AXC80	AXC80Z	10	-	-	0	155	19	80	AXC gantry connection 80-80
	AXC80S/A	-	-	10	10				
AXC80	AXC120Z	15	-	6	-20 ¹⁾ / 10	194	16	140	AXC gantry connection 80-120
	AXC120S/A		-		-20 ¹⁾ / 25				
AXC120	AXS280	30	-	-	-40 ¹⁾	170	30/90 ²⁾	200	AXC gantry connection 120-280
AXC60	AXDL110	49	174	-	5,5	160	90	58	AX gantry connection 60-110
	AXDL160	63	237	-	5	220	120	78	AX gantry connection 60-160
AXC80	AXDL160	63	237	-	5	220	120	78	AX gantry connection 80-160
	AXDL240	49	287	-	11	220	120	100	AX gantry connection 80-240
AXC120	AXDL240	49	287	-	11	220	120	100	AX gantry connection 120-240

1) Position on X-axis fixed with cylinder pins.
 2) With table length 600 mm.

I A-standard connection

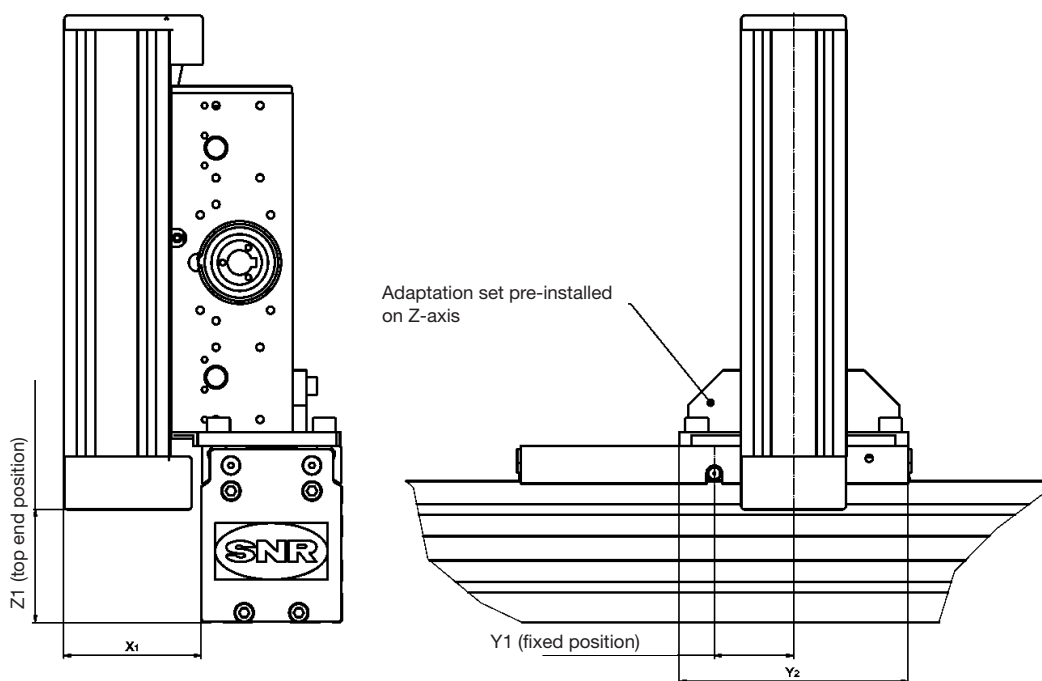
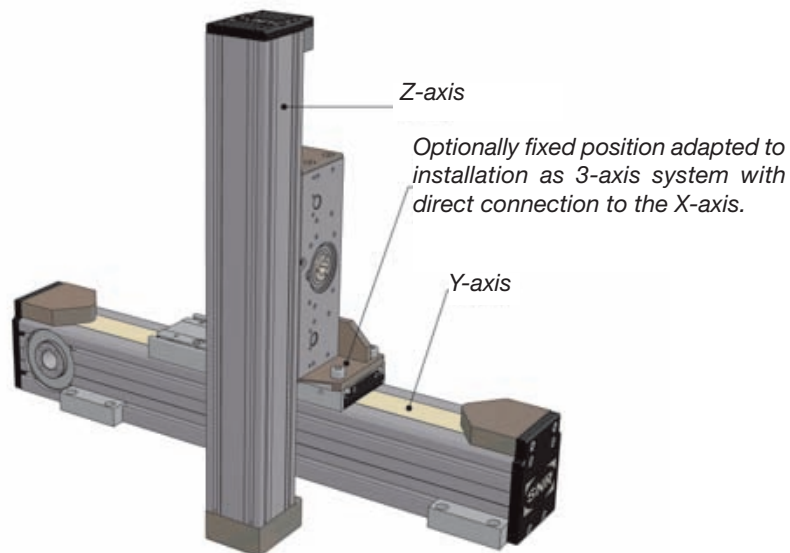

Y-axis	Z-axis	X1	Y1	Y2	Z1	Article description
AXC80	AXC60A	78	45	130	64	AXC A-standard connection 80-60
AXC80A	AXC60A	78	20	130	64	
AXC120	AXC80A	92	59	150	87,5	AXC A-standard connection 120-80
AXC120A	AXC80A	92	0/55	150	87,5	
AXDL110	AXC60A	90	0 / 18	130	29	AXC A-standard connection 110-60
AXDL160	AXC80A	110	0	150	22,5	AXC A-standard connection 160-80
AXDL240	AXC120A	140	0	200	20	AXC A-standard connection 240-120



I AXDL angle connection

• X-Y profile assembl

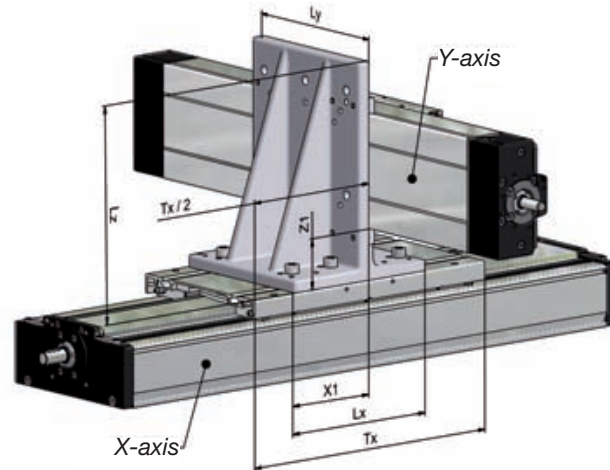

Aluminium sand casting
EN AC-AISi7Mg0.3 ST6

X-axis	Y-axis	Lx	X1	Ly	Z1	Lz	Article description
AXDL110	AXDL110	160	90	156	49	209	AXDL angle connection X110-Y110
AXDL160	AXDL110	160	90	156	49	209	AXDL angle connection X160-Y110P
AXDL160	AXDL160	220	120	236	63	287	AXDL angle connection X160-Y160
AXDL240	AXDL160	220	120	236	63	287	AXDL angle connection X240-Y160P
AXDL240	AXDL240	220	120	236	49	287	AXDL angle connection X240-Y240

• X-Y tabletop mount

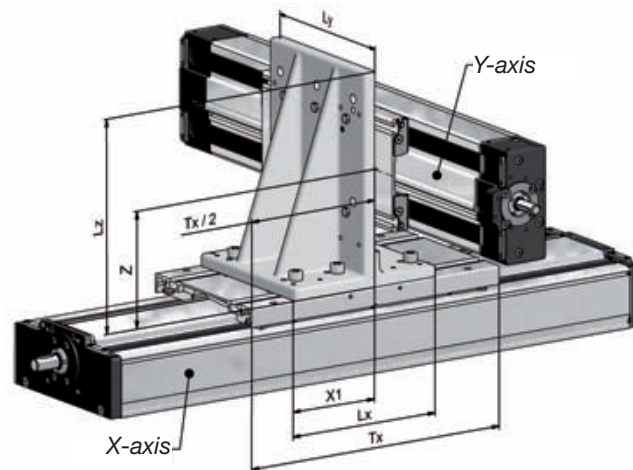

Aluminium sand casting
EN AC-AISi7Mg0.3 ST6

X-axis	Y-axis	Lx	X1	Ly	Z	Lz	Article description
AXDL110	AXDL110	160	90	156	114	209	AXDL angle connection 110-110
AXDL160	AXDL110	160	90	156	114	209	AXDL angle connection X160-Y110T
AXDL160	AXDL160	220	120	236	130	287	AXDL angle connection 160-160-2
AXDL240	AXDL160	220	120	236	144	287	AXDL angle connection X240-Y160T
AXDL240	AXDL240	220	120	236	176,5	287	AXDL angle connection 240-240

• **Y-Z profile assembly**

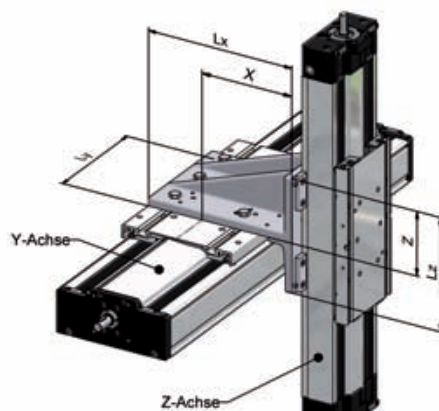

Aluminium sand casting
EN AC-AISi7Mg0.3 ST6

Y-axis	Z-axis	Lx	X	Ly	Lz	Z	Article description
AXDL110	AXDL110	209	114	156	160	90	AXDL angle connection Y110-Z110
AXDL160	AXDL110	209	130	156	160	90	AXDL angle connection Y160-Z110P
AXDL160	AXDL160	287	144	236	220	120	AXDL angle connection Y160-Z160
AXDL240	AXDL160	287	176,5	236	220	120	AXDL angle connection Y240-Z160P
AXDL240	AXDL240	287	176,5	236	220	120	AXDL angle connection Y240-Z240

• **Y-Z tabletop mounting**

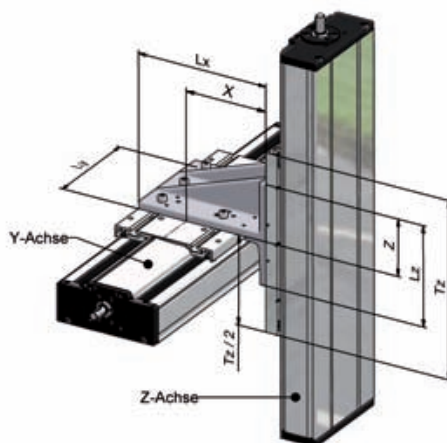

Aluminium sand casting
EN AC-AISi7Mg0.3 ST6

Y-axis	Z-axis	Lx	X	Ly	Lz	Z	Article description
AXDL110	AXDL110	209	114	156	160	90	AXDL angle connection 110-110
AXDL160	AXDL110	209	130	156	160	90	AXDL angle connection Y160-Z110T
AXDL160	AXDL160	209	130	156	160	90	AXDL angle connection 160-160-2
AXDL240	AXDL160	287	176,5	236	220	120	AXDL angle connection Y240-Z160T
AXDL240	AXDL240	287	176,5	236	220	120	AXDL angle connection 240-240



I AXLT direct connection

The linear tables of the AXLT series are conceived so that they can be mounted in the simplest way to compound tables. Depending on size an adapter can even be omitted here.

Compound table variation in the layout base board on table top

In this layout linear tables of same size or the next smallest size can be installed on the table top. An adapter plate in both cases is unnecessary.

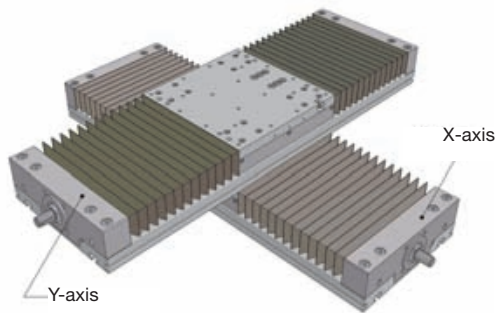

- Combination of same sizes

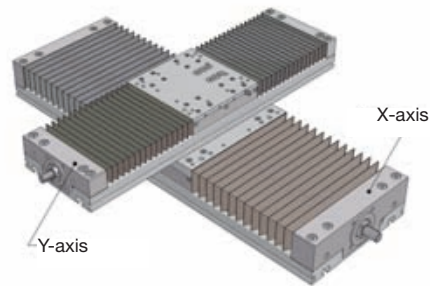

- Combination with next smaller size

X-axis	Y-axis			
	AXLT155	AXLT225	AXLT325	AXLT455
AXLT155	AXLT direct connection 155-155			
AXLT225	AXLT direct connection 225-155	AXLT direct connection 225-225		
AXLT325		AXLT direct connection 325-225	AXLT direct connection 325-325	
AXLT455			AXLT direct connection 455-325	AXLT direct connection 455-455

I AXLT cross connection

Compound table variation in the layout table top on table top

Also in this layout the linear tables (X-axis) can be combined either with the same or the next smallest size. An adapter plate is no longer necessary from size 325 (X-axis).

- Combination of same sizes

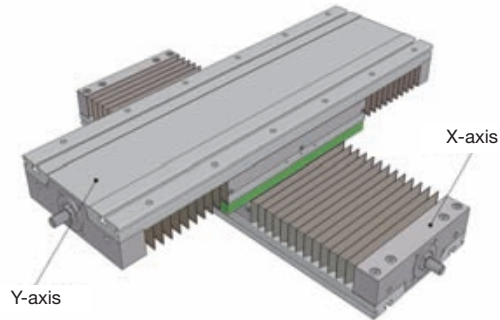

- Combination with next size down

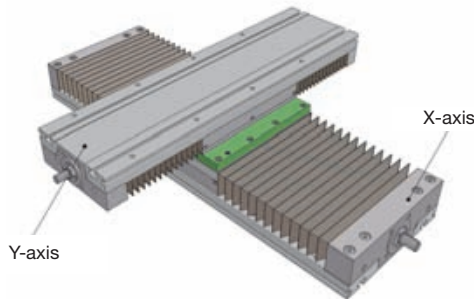

X axis	Y axis				
	AXLT155 (L _T =220)	AXLT225 (L _T =320)	AXLT325 (L _T =320)	AXLT325 (L _T =450)	AXLT455
AXLT155	AXLT Cross connexion 155-155				
AXLT225	AXLT Cross connexion 225-155	AXLT Cross bindung 225-225			
AXLT325		AXLT Cross connexion 325-225	AXLT Cross connexion 325-325	AXLT Cross connexion 325-325	
AXLT455				AXLT Cross connexion 455-325	AXLT Cross connexion 455-455

T = table length in mm.



I SNR gantry support legs

SNR gantry support legs can be used with the AXC series as well as with the AXS series.

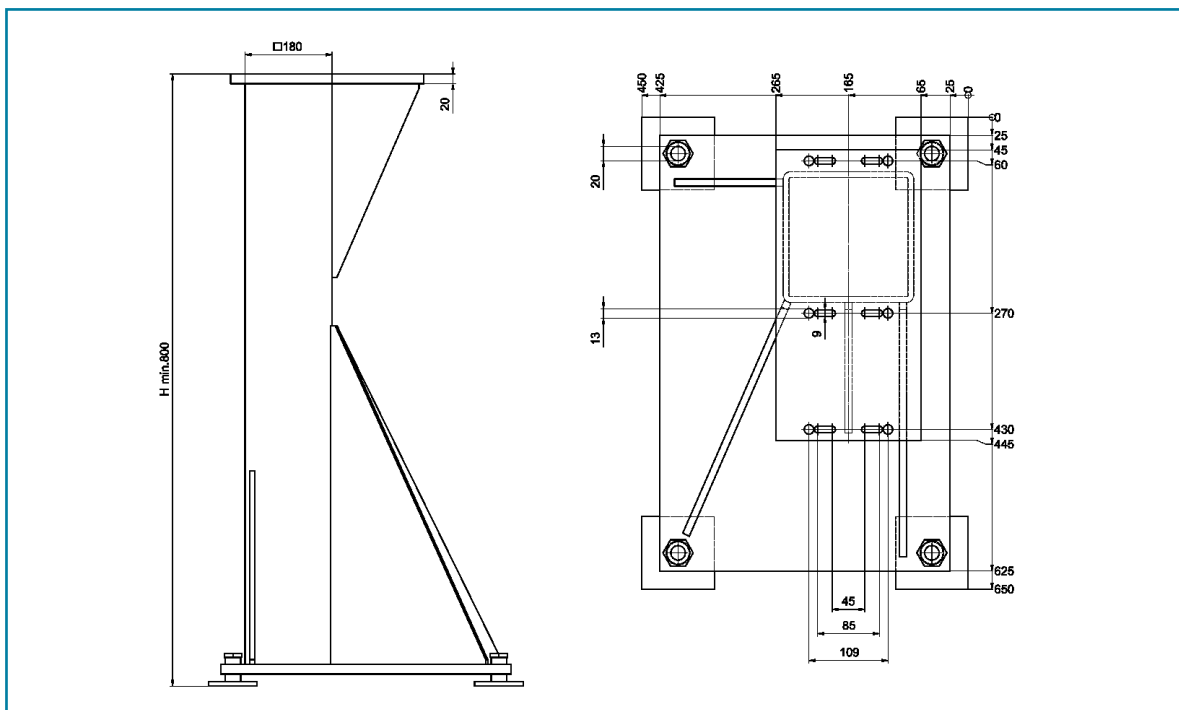

I Groove cover for AXC

I Groove insert

To facilitate the cleaning of the linear axis or to prevent heavy contamination, the groove of the profile body can be sealed with the corresponding groove insert. If inductive proximity switches are used (see page 92), the groove insert is included as standard.

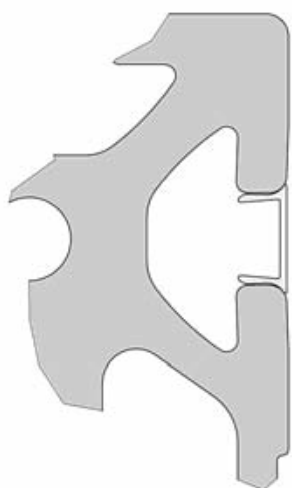

Groove insert Al
Color: natural



Groove insert PP
Color: black

Linear axis	Material	Installation options	Article description
AXC40	PP	Underneath	5.PP.black.2000L
AXC60		all	
AXDL240		by the side, upper groove	
AXC80	PP	all	6.PP.black.2000L
	Anodized AL	all	6.2000L natural
AXC120	PP	all	8.PP.black.2000L
AXDL240	Anodized AL	Underneath and by the side lower groove	8.3000L natural

Complete Systems



Our standard axis systems facilitate a clear reduction of design costs. The range includes powerful 2-axis or 3-axis systems that are made of practical combinations of the AXC, AXDL and AXS range.

I Standard combinations in the AXC and AXDL range

All sets and kits are pre-arranged with ready-to-install switches, energy chains, drives and all fixing hardware. If no energy chain is desired, the individual components are delivered with the required fixing hardware. The tables for the direct, gantry, cross and A standard connections in the chapter on fastening elements (from page 100) give information about the possible combinations of axis sizes and designs according to the images below.

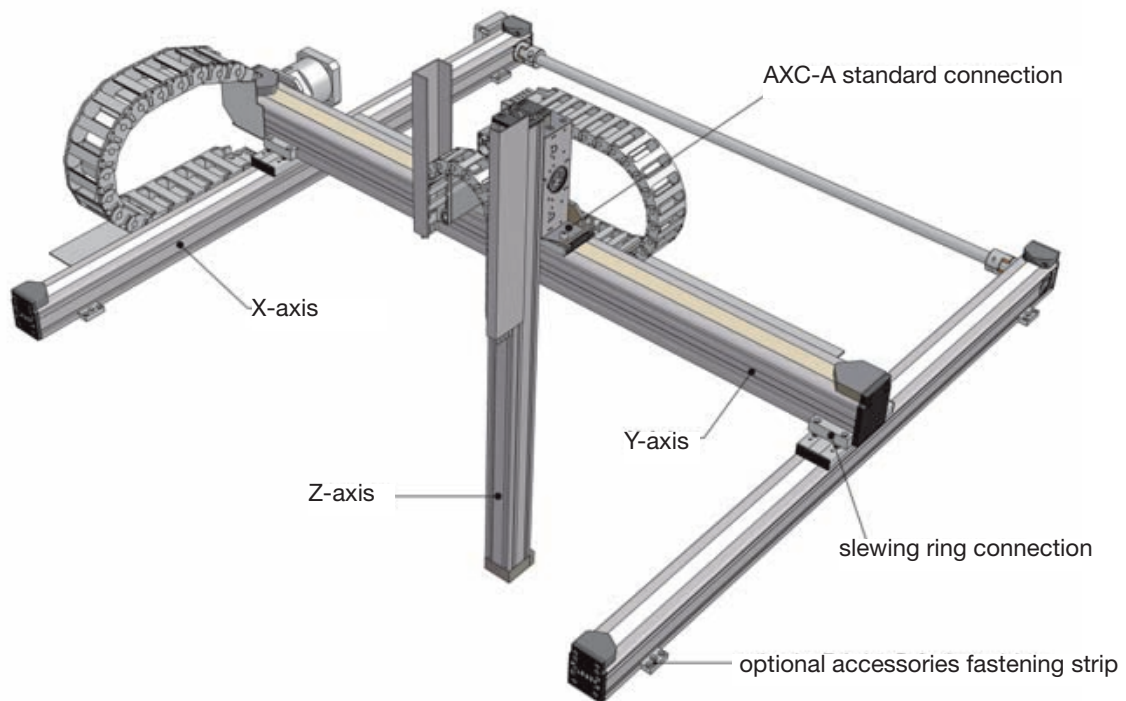

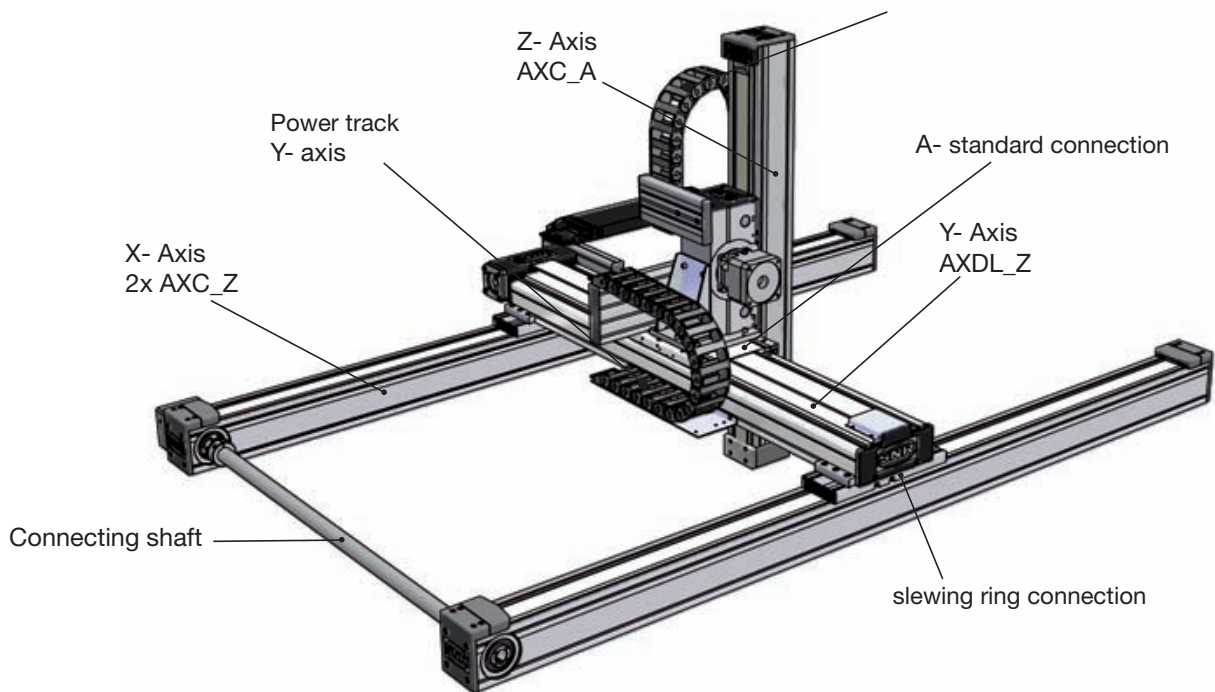
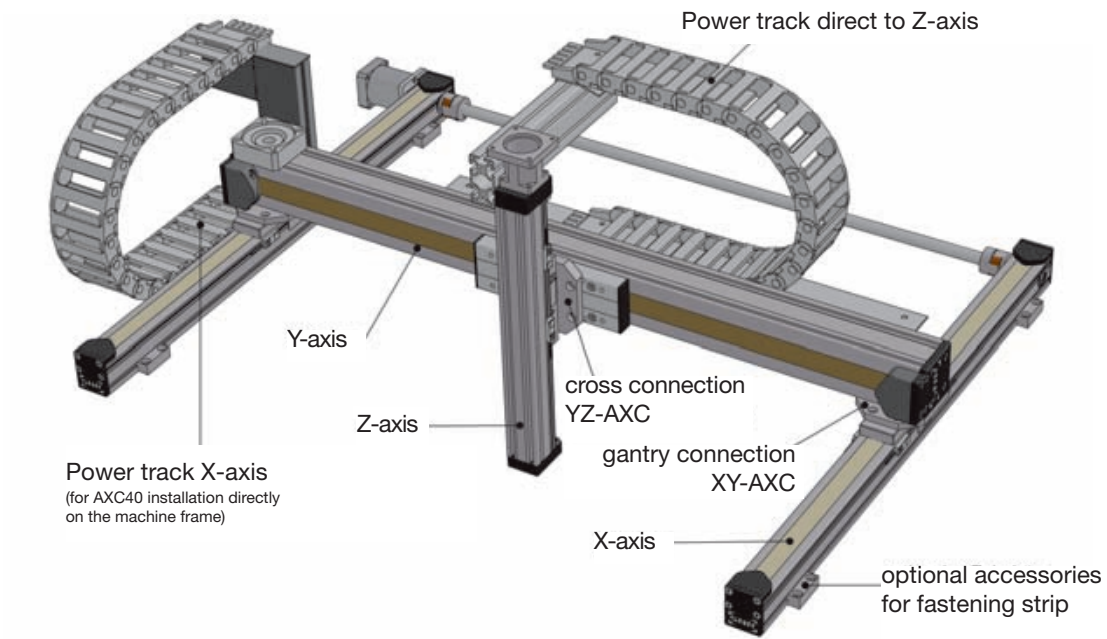

Complete Systems

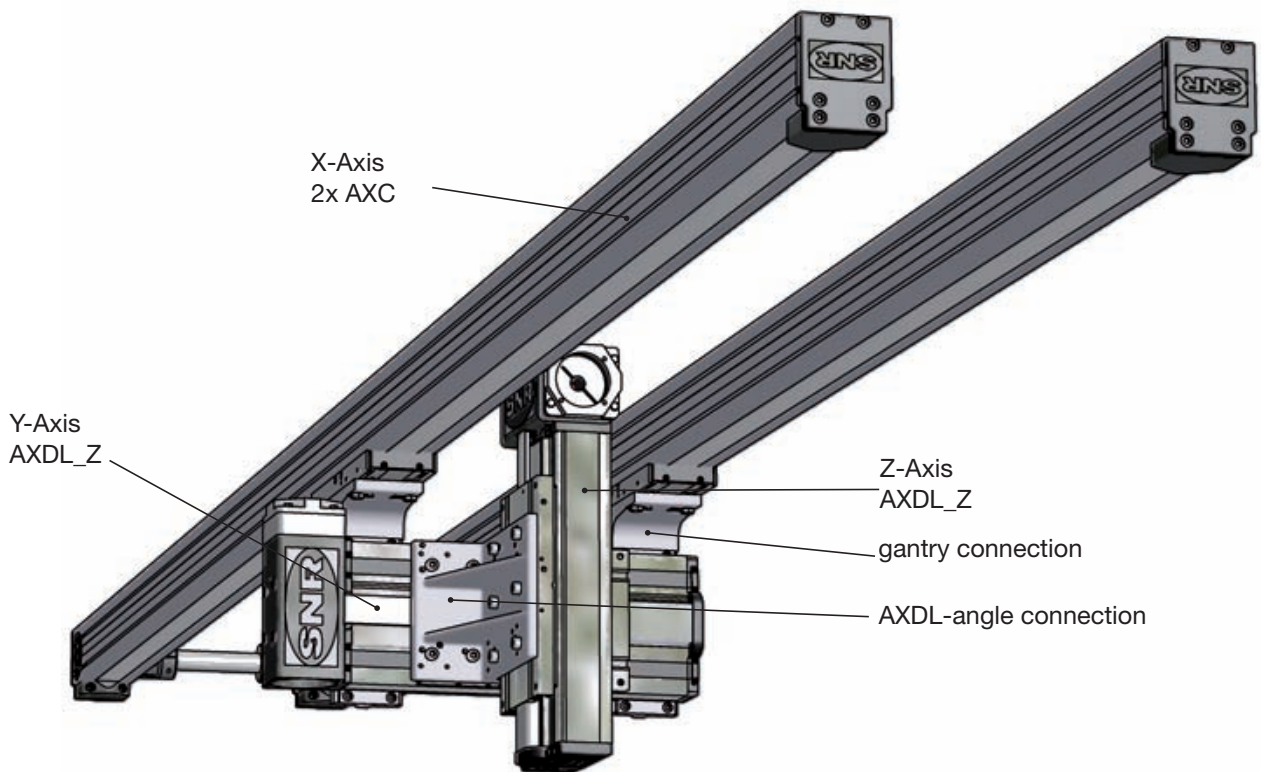
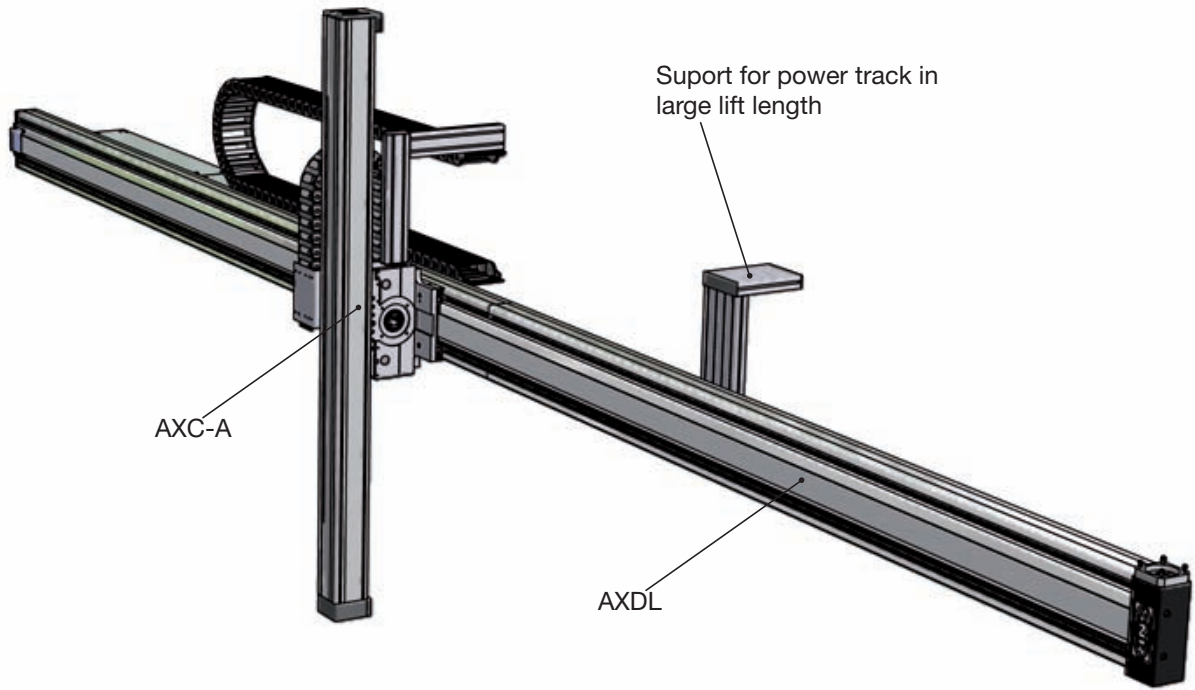

Standard combinations in the AXS, AXC and AXDL range

In large lift lengths and rising requirements for the load-bearing capacity and stiffness we offer the optimal alternative with a standard combination from the AXC, AXDL and AXS ranges.

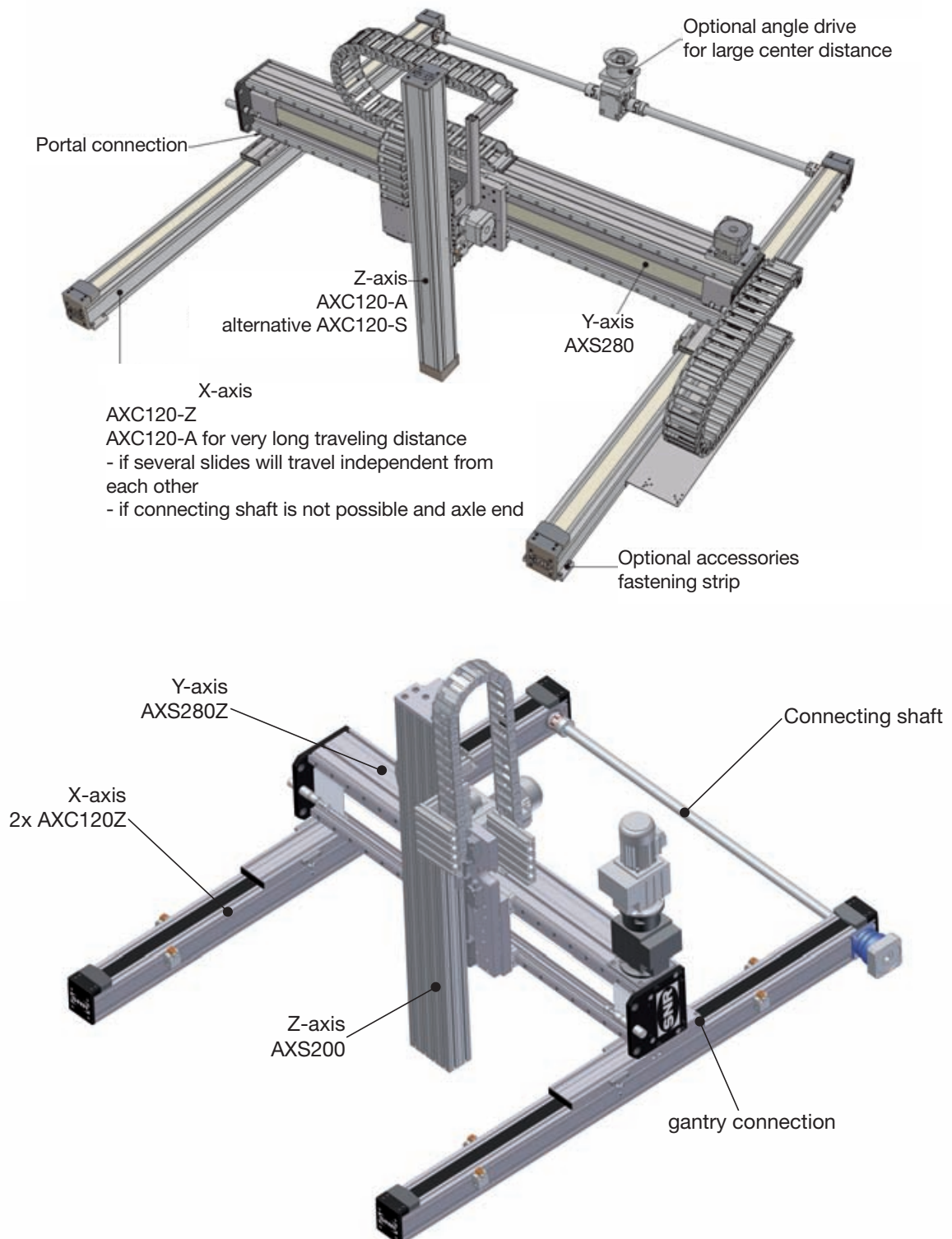



I Standard combinations in the AXS range

SNR standard systems from the AXS range are available in the top load range.

- Standard layout with synchronous belt-driven gantry axis

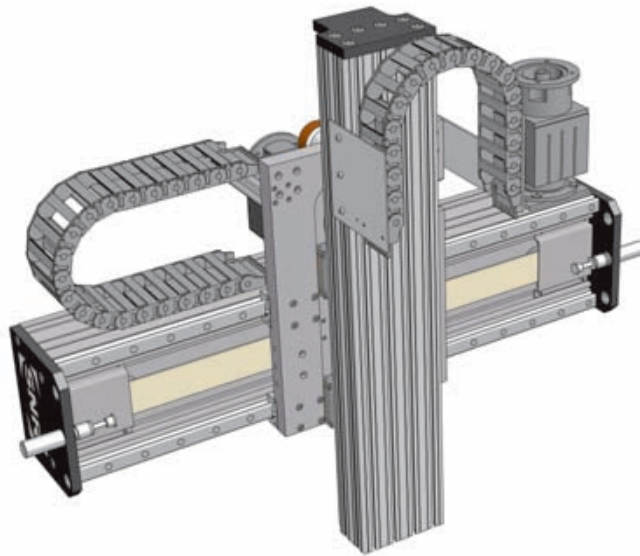

- Standard layout with rack-and-pinion-driven gantry axis

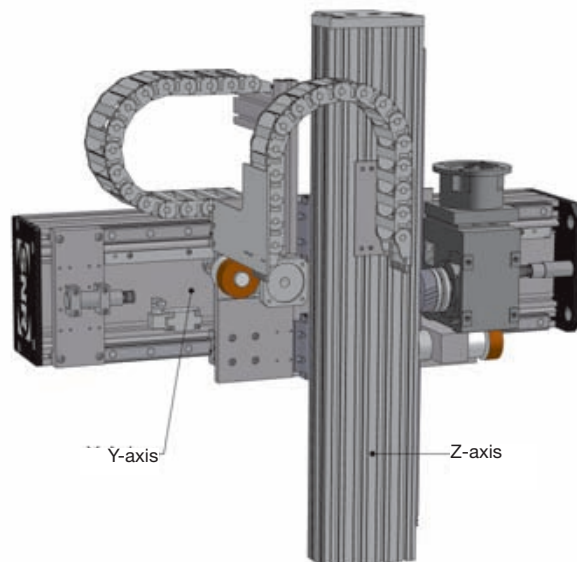

I Overview of AXS combinations

Z axis		Y axis		
		Drive synchronous belt AXS280ZGxx-B	Drive rack and pinion	
			AXS280M200-B	AXS460M250-B
Drive rack and pinion	AXS200M200-B	•	-	-
	AXS200M250-B	-	•	-
	AXS230M320-B	•	•	•
	AXS280M400-B	-	-	•
	AXS120TM400-B	•	-	-

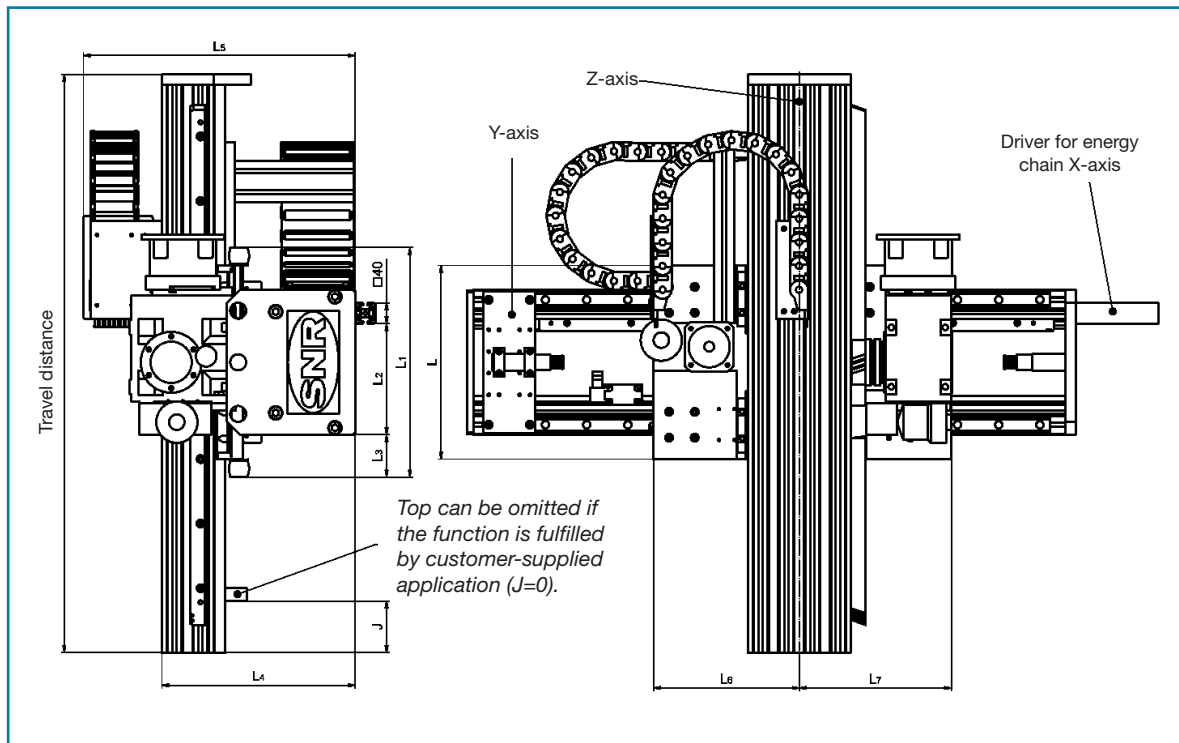

Y axis	Z axis	K	L	L1	L2	L3	L4	L5	L6	L7
AXS280ZGxx-B	AXS200M200-B	725	610	680	215	51	382	520	200	200
	AXS230M320-B	515	312	420	215	70	442	581	350	350
AXS280M200-B	AXS200M250-B	490	375	445	215	82,5	375	528	283	295
	AXS230M320-B	515	312	420	215	70	442	581	350	350
AXS460M250-B	AXS230M320-B	695	492	600	210	70	598	737	350	350
	AXS280M400-B	690	493	600	210	70	612	752	355	355

I Pneumatic connection for sealing air or suction

SNR linear axes can be supplied with a connector for sealing air or suction. In this case, the best-quality seal with cover strip or felt wipers and internal seal must be available (option A or D in AXDL).

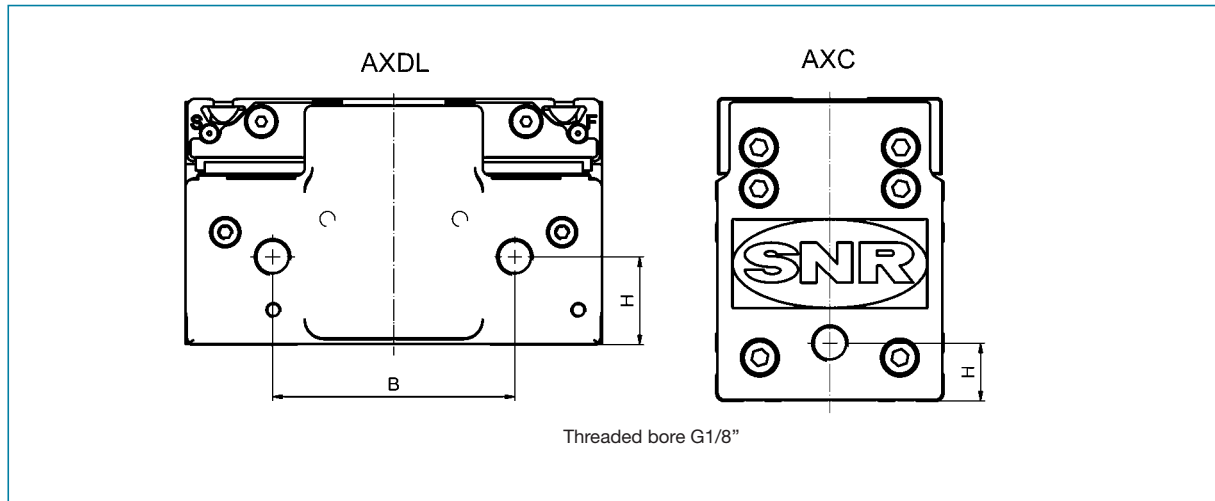

Axis type	H	B	Availability
AXC60Z	15	-	both end covers
AXC80Z	18	-	
AXC120Z	30	-	
AXDL110Z	23	64	Deflection side
AXDL160Z	25	105	
AXDL240Z	46	145	
AXC40S	11	-	Support bearing side
AXC60S	21	-	
AXC80S	22	-	
AXC120S	25	-	Support bearing / locating bearing side
AXDL110S	12	74	Support bearing side / locating bearing lateral surface
AXDL160S	25	105	both end covers
AXDL240S	46	145	



General information about lubrication

Greases for screw-type drives and/or ball rail system

Under normal circumstances, grease SNR LUB EP is used. Specific requirements in certain environmental conditions require the use of a suitable grease. In case of re-lubrication with other greases, check that the greases are compatible.

Name	Oil type, consistency regulator	NLGI-class DIN 51818	Walk penetration DIN ISO 2137 at 25°C [0,1 mm]	Base oil viscosity DIN51562 at 40°C [mm ² /s]	Thick-ness [kg/m ²]	Tempera- ture range [°C]	Properties	Field of application
SNR LUB EP	Mineral oil, Extreme pressure additive Lithium soap	2		150	900	-30...+110	Normale Bedingungen Standardbefettung	General engineering
SNR LUB FOOD	paraffin mineral oil / aluminium complex soap	2	265... 295	approx. 240	920	-30...+110	Good corrosion protection, very good adhesion, high water resistance, NSF H1 registered*	Food industry
Klübersynth BEM34-32	Synthetic CW - oil / special - calcium soap	2	265... 295	approx. 30	890	-30...+140	Particularly pressure resistant, good wear protection, low starting torque	Clean-room applications
Klübersynth UH1 14-151	Synthetic KW - oil / Esteroil / aluminium complex soap	1	310... 340	approx. 150	920	-45...+120	Good corrosion protection, good wear protection, high water resistance, NSF H1 registered*	Pharmaindustry, Food industry

* This grease is registered as H1 product: it has been developed for occasional, technically unavoidable contact with foodstuff. Experience shows that the grease can also be used for the corresponding applications in the pharmaceutical and cosmetic industry, on the conditions listed in the product information. However, there are no specific test results, for instance, on the biocompatibility, as may be required under certain circumstances in the pharmaceutical area. Therefore, before use in this area by equipment manufacturers and distributors, corresponding risk analyses must be performed. If necessary, measures to avoid health hazard and injuries must be taken. Source: Klüber Lubrication)

I Lubrication oil for roller guide

Generally, the burnished steel shafts of the roller guide are lubricated with Shell Omala 460.

Name	Type of lubricant	kinematic viscosity DIN51562 at 40°C [mm²/s]	Thick- ness [g/cm]	Tempera- ture range [°C]	Properties	Field of application
Shell Omala 460	Mineral oil and additive.	460	904	-10... +90	Good durability and temperature stability as well as corrosion protection	General engineering
Klüberoil 4 UH1-460N	Polyal-phaole film	460	860	-30... +120	Good durability and wear protection, NSF H1 registered*	Pharmaceuti- cal industry Food industry

I Automatic lubricant dispenser

Automatic lubrication guarantees steady and regular lubrication of the guidance and drive elements on the linear axes. The automatic lubricant dispenser optimises the lubrication process without modifying your equipment. Lubricant dispensers are connected to the lubrication port of the linear axis. Check that each lubrication point requires a separate lubricant dispenser. The lubricant dispenser can be supplied with different grease or oil type. SNR offers various models of lubricant dispensers.



Experts
& Tools

NTN SNR

For more information contact our SNR application engineers.

I Central lubrication port

SNR linear axes can, on demand, be supplied with a connection for central lubrication equipment. For more information contact our SNR application engineers.



Special solutions

Apart from the standard range, SNR also offers special solutions for client-specific applications. Constructive solutions are developed with product quality, affordability and user benefits. The examples given below represent some special solutions. For more information contact our SNR application engineers

I Linear axes with several tables

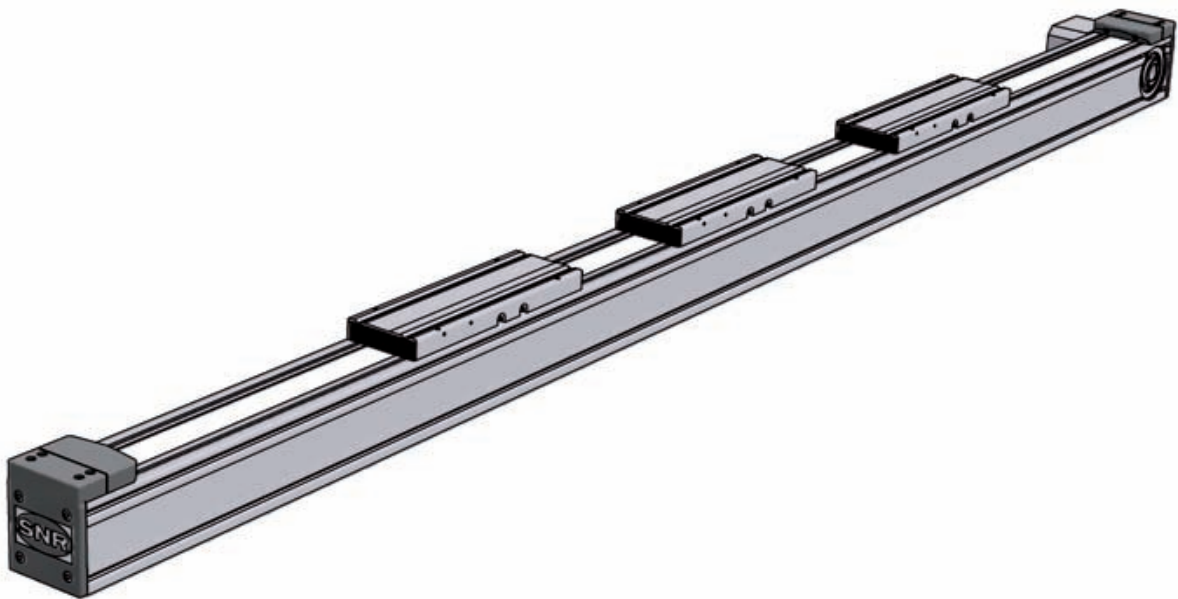

This solution can be designed differently, depending on the type of linear axis.

AXC with screw-type drive and AXDL with synchronous belt drive:

- Two synchronous belt drives (left-hand/right-hand threads)
- One synchronous belt drive, and, if necessary, many asynchronous belt drives

AXC and AXS with synchronous belt drives:

- Several carriages with fixed intermediate distances

AXC-A and AXS with pinion drive:

- several independently movable tables

I Linear axes with contra directional tables

Two carriage systems can be positioned contra directionally with the help of a drive element (synchronous belt drive); this makes it possible to load or unload two conveyor belts.

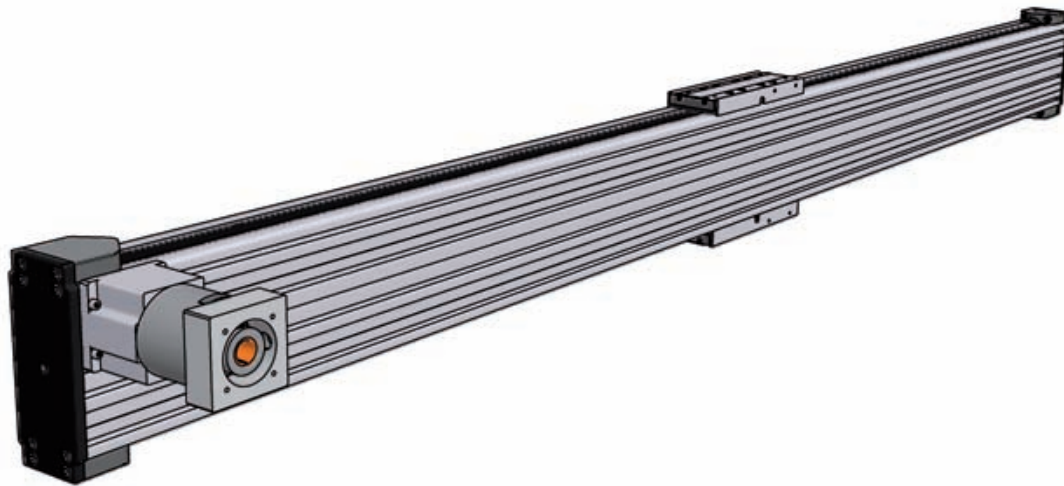

Lifting axes with holding brakes and clamping elements (vertical axis)

See page 14 for the description.

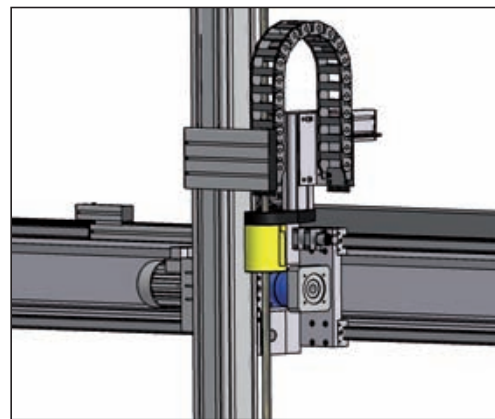



I Telescopic axis AXS240T

Compared to the standard telescopic axis (see page 64-65), the special linear axis AXS240T can take higher loads and torque loads. Moreover, high rigidity can be attained using AXDL series section size 240.

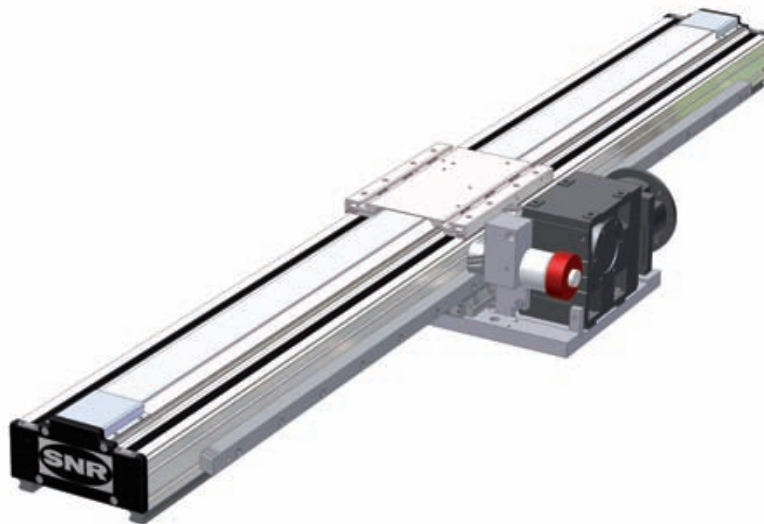

I AXC40Z with sliding guide system

The robust and compact design of the linear axis AXC40 with synchronous belt drive and sliding guide system is outstanding for its low net weight and offers an economical alternative to traditional linear units. The linear axis can be used in various applications thanks to other advantages such as maintainability, minimum noise level and clean running without lubricant.

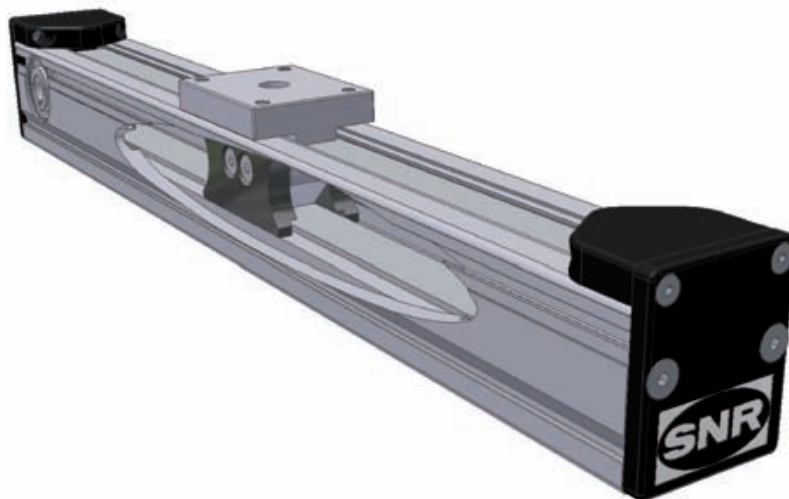

Linear axes with hand wheel and digital position indicator

This model is particularly suitable for simple manual adjustments and positioning tasks. The digital position indicator allows the carriage position to be read directly.



Linear axes with position sensor

The linear systems can be fitted with position sensors for path measurement. The actual carriage position can then be ascertained and transmitted to the control unit. A distinction can be made between optical, magnetic and inductive measurement methods. In the example below the linear axis is equipped with an incremental opto-electrical system with measurement precision.

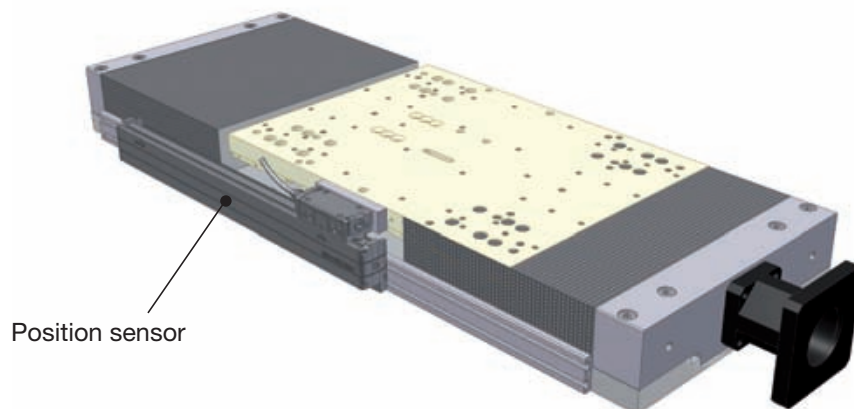



I Models for clean rooms

SNR linear axes with synchronous belt drives and screw-type drives can under certain circumstances and application conditions be implemented in clean-room applications. For more information, do not hesitate to contact our SNR application engineers.

Basically, a guarantee for this clean-room class can only be given for the same operating parameter. It is not possible to give a general guarantee that a clean-room class can be reached. Generally, a clean-room class can only be classified after comprehensive tests with the actually prevalent conditions.

I Corrosion-resistant model

SNR linear axes can upon demand be supplied in a corrosion-resistant model. From external screws in A2 to corrosion-resistant guidance elements. For further models, please contact our SNR application engineers.

I Linear ball unit

The unit, which consists of two guidance elements (example middle flange linear ball unit) and one drive element (example trapezoidal thread drive), offers the user an economical means of moving lower weight. The equipment components can also be provided in a corrosion-resistant model.



I Type designation for SNR Linear axes

Order example

AXC80 S G 2005 - B - 1000 - 1380 - V2 - 00 - 00 - A - 0
 1 2 3 4 5 6 7 8 9 10 11 12

1	AXC80	Model designation as entered in the drive type catalogue		
		Drive type		
2	S	Z: Synchronous belt drive	S: Ball screw	M: Rack and pinion drive
		A: Synchronous belt drive	T: Trapezoidal thread drive	O: no drive
		Drive design with synchronous belt drive		
3		HL (HR): Mounting surface machined on left side (right) and drive for hollow shaft HW: Hollow shaft WL (WR): Free end of the shaft left (right) WD: Free ends of the shaft on both sides KL (KR): Integrated coupling for main drive pinion side, left (right) KLK (KRK): Integrated drive coupling, left side (right) + integrated coupling for spacer shaft right (left)	PL (PR): integrated planetary reduction gearbox left (right) PLK (PRK): Integrated planetary reduction gearbox left (right)+ integrated coupling for spacer shaft right (left) GL (GR): Coupling and coupling cone left (right) GLK (GRK): Coupling and coupling cone left (right) + integrated coupling for spacer shaft right (left) FL (FR): Drive adapter flange (direct connection between drive shaft and hollow shaft of unit), left side(right)	
		For screw-type drive		
		G: Coupling cone + coupling	U: Deflection belt drive	No information: free drive shaft
		Size ID for drive design		
		For synchronous belt drive		
4	2005	Shaft or hollow shaft diameter (HW, WL, WR, WD, FL, FR) Coupling internal diameter (KL, KR, GL, GR)	Reduction ratio (PL, PR). For PLK or PRK design, only the reduction ratio is indicated.	
		For screw-type drive Spindle diameter and thread pitch	For rack and pinion drive Input constant: 160/200/250/320/400	
5	B	Guidance system B: Ball rail guide, standard carriages L: Roller guide, standard carriage C: Ball rail guide, long carriage M: Roller guide, long carriage F: without guidance system (feed axis), standard carriages		
6	1000	Travel range		
7	1380	Total length (lift + additional length stipulated in the catalogue)		
	V	Reinforced spindle supports (not specified if not applicable)		
8	A	Protection from contamination (not applicable if not available or available as standard)		
		For synchronous belt drive A: Cover band For AXDL D: with felt wiper and internal seals	For linear tables F: Bellows	
	2	Spindle support (number of sets, not specified if not applicable)		
9	0	Switch combination, left inductive/ or interior) ID number as entered in the catalogue page 99		
10	0	Switch combination, right inductive/ or interior) ID number as entered in the catalogue page 99		
11	A	Drive adaptation ID number as entered in the catalogue (ID number 0 if not available) pages 82, 85 and 87		
12	0	Optional reference is internally allocated and indicates options, built-in components and special designs that are indicated in plain text.		

Enquiry guide



Date	
Bid to	
Company	
Contact person	
Function/department	
Address	
Telephone	Fax:
E-mail	
Project name	
Type of enquiry	<input type="checkbox"/> One-off requirement Item
	<input type="checkbox"/> Regular requirement Piece/year <input type="checkbox"/> Desired date for: Pieces CW
	<input type="checkbox"/> New construction <input type="checkbox"/> Technical improvement
	<input type="checkbox"/> Cost reduction <input type="checkbox"/> Price until now: Euro
	<input type="checkbox"/> Alternative to competition <input type="checkbox"/> Competition is:

• Application parameters

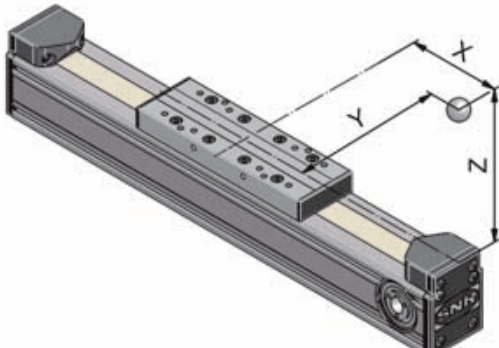
Application parameters	Single axis	Multi-axes system		
		X	Y	Z
Single-axis/multi-axes system (centre-to-centre distance) [mm]				
Mounting position: horizontal/vertical				
Travel distance [mm]				
Traverse rate [m/min]				
Acceleration [m/s ²]				
Traverse time, [s]				
Cycle time [s]				
Desired service life, [h]				
Operating conditions (dust, chippings, etc.)				
Useful load [kg]				
Power, [N]				
Co-ordinates of the centre of gravity Load X, [mm]				
Co-ordinates of the centre of gravity Load Y, [mm]				
Co-ordinates of the centre of gravity Load Z, [mm]				
Co-ordinates of the centre of gravity Power X, [mm]				
Co-ordinates of the centre of gravity Power Y, [mm]				
Co-ordinates of the centre of gravity Power Z, [mm]				
	Observations:			

Device to linear axis AX

Please cross out/enter applicable

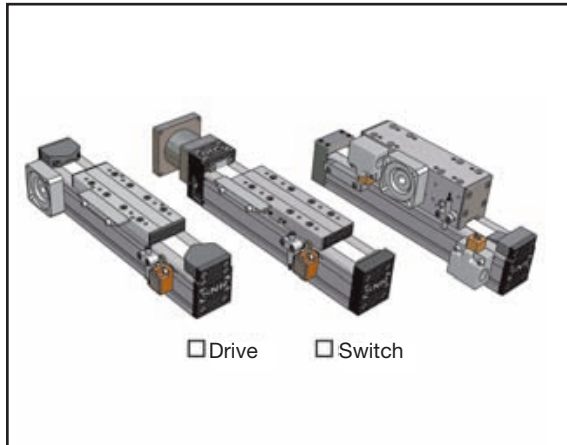

Built-in components left

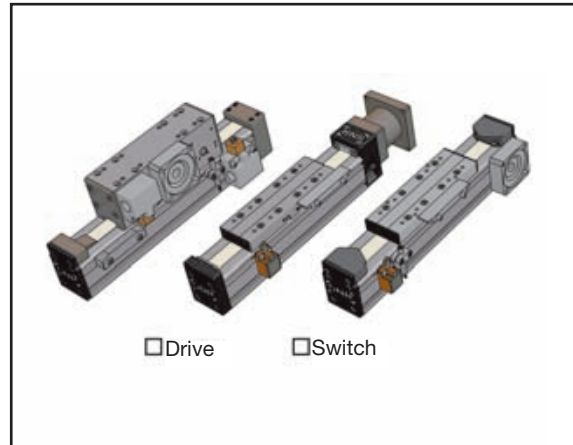

Built-in components right

Type of drive		Guidance system	
<input type="checkbox"/> Ball screw		<input type="checkbox"/> Ball rail systems	
<input type="checkbox"/> Trapezoidal thread drive		<input type="checkbox"/> Roller guide	
<input type="checkbox"/> Synchronous belt drive		<input type="checkbox"/> no guidance	
<input type="checkbox"/> Rack and opinion drive			
<input type="checkbox"/> carriage (Omega drive)			
<input type="checkbox"/> no drive			
Drive model			
In toothed-belt drive		In ball screw	
<input type="checkbox"/> Hollow shaft		<input type="checkbox"/> Coupling cone + coupling	
<input type="checkbox"/> free shaft end <input type="checkbox"/> right <input type="checkbox"/> left		<input type="checkbox"/> Deflection belt drive	
<input type="checkbox"/> Integrated coupling <input type="checkbox"/> right <input type="checkbox"/> left		<input type="checkbox"/> free drive shaft	
<input type="checkbox"/> + integrated coupling for connecting shaft <input type="checkbox"/> right <input type="checkbox"/> left			
<input type="checkbox"/> integrated planetary reduction gearbox <input type="checkbox"/> right <input type="checkbox"/> left			
<input type="checkbox"/> + integrated coupling for connecting shaft <input type="checkbox"/> right <input type="checkbox"/> left			
<input type="checkbox"/> Coupling and coupling cone <input type="checkbox"/> right <input type="checkbox"/> left			
<input type="checkbox"/> + integrated coupling for connecting shaft <input type="checkbox"/> right <input type="checkbox"/> left			
<input type="checkbox"/> Drive adapter flange <input type="checkbox"/> right <input type="checkbox"/> left			
Switch			
<input type="checkbox"/> mechanical limit switches	<input type="checkbox"/> IP 30	<input type="checkbox"/> IP 67	
<input type="checkbox"/> inductive proximity switches	<input type="checkbox"/> Break contact NC (standard)	<input type="checkbox"/> Make contact NO	
<input type="checkbox"/> Reference switch	<input type="checkbox"/> PNP (standard)	<input type="checkbox"/> NPN	

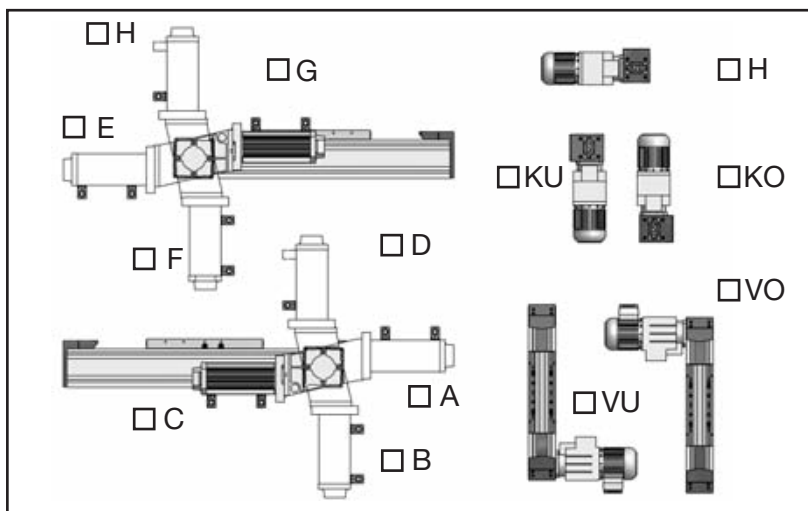

Mounting position angular gear

Mounting position linear axis

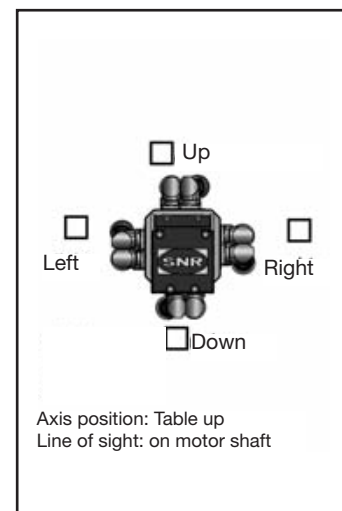

Location motor connection



Other Catalog Documentation



You can find more information about SNR products from the Linear Motion segment in our other catalogs or on our homepage:

www.snr-bearings.com/Produkte/Linear Motion



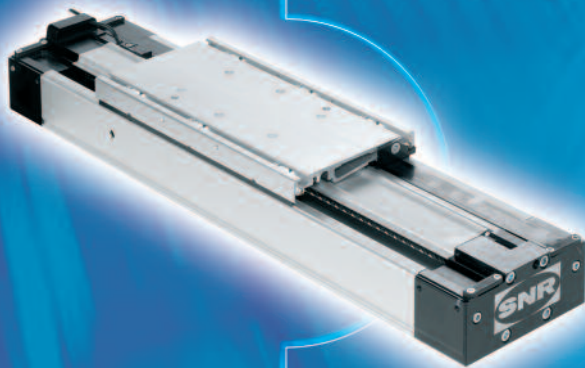

contatto
contatto

お問い合わせ

contacto
contacto

contact
contact

www.ntn-snr.com

الاتصال ب

联系我们
Lian Xi Wo Men

Kontakt
Kontakt

contato
contato

AUTOMOTIVE / AEROSPACE / INDUSTRY

